

ISO MICROCYLINDERS MIR/CDEM Series 1280/1291/GLB

PNEUMAX

Microcylinders according to standard ISO 6432 "MIR"
rolled end covers (series 1200, section 4)



**Basic version, without rear eye
and push/pull rod**



Ordering code

12 .Ø.stroke.

- = Version with non magnetic piston
- **M** = Magnetic piston **STD**
- **A** = Adjustable cushioning (from Ø16)
- **A.M** = Cushioning with magnetic piston (from Ø16) **STD**
- **T** = HNBR seals version
- **V** = FPM seals version

- **80** = Basic version **STD**
- **81** = Without rear eye version
- **82** = Push/Pull rod version (through rod)
- **91** = Basic version front spring (max stroke 50 mm) **STD**
- **92** = Basic version rear spring, from Ø16 (max stroke 50 mm)
- **93** = Without rear eye front spring (max stroke 50 mm)
- **94** = Without rear eye rear spring from Ø16 (max stroke 50 mm)

Bore:

Ø8, Ø10, Ø12, Ø16, Ø20, Ø25, Ø32

Standard strokes

Ø 8 and Ø 10: 15-25-50-75-80-100 mm

Ø 12 and Ø 16: 15-25-50-75-80-100-150-160-200-250-300 mm

Ø 20 and Ø 25: 15-25-50-75-80-100-150-160-200-250-300-320-350-400 mm

Ø 32: 15-25-50-75-80-150-160-200-250-300-320-350-400-450 -500 mm



**Example code
1280.20.050.AM**

(Basic version, diameter 20mm, stroke 50mm,
cushioning, magnetic)



Construction characteristics

End covers	hard anodised aluminium
Barrel	stainless steel AISI 304
Piston rod	stainless steel
Piston	brass (ø8-10-12) aluminium (ø16-20-25)
Seals	Standard: NBR Oil resistant rubber, PUR Piston rod seals (HNBR or FPM seals available upon request)
Mounting	steel painted in cataphoresis
Forks	zinc plated steel
Single-acting springs	C98 zinc plated steel for springs
Cushioning length	ø 16 - 20 - 25 - 32 mm 15 - 18 - 18 - 18

Technical characteristics

Fluid	filtered air and preferably lubricated
Maximum working pressure	10 bar
Working temperature	-5°C - +70°C with standard seals magnetic or non magnetic piston -5°C - +80°C with FPM seals magnetic piston -5°C - +80°C with HNBR seals magnetic piston -5°C - +120°C with HNBR seals non magnetic piston -5°C - +150°C with FPM seals non magnetic piston

Please follow the suggestions below to ensure a long life for these cylinders:

- use clean and lubricated air
- correct alignment during assembly with regard to the applied load so as to avoid radial components or bending the rod.
- avoid high speeds together with long strokes and heavy loads: this would produce kinetic energy which the cylinder cannot absorb, especially if used as a limit stop (in this case use mechanical stop device)
- evaluate the environmental characteristics of cylinder used (high temperature, hard atmosphere, dust, humidity etc.)

Please note: air must be dried for applications with lower temperature.

Use hydraulic oils H class (ISO Vg32) for correct continued lubrication.

Our Technical Department will be glad to help.

Standard strokes

ø 8 and ø 10

15 - 25 - 50 - 75 - 80 - 100 mm

ø 12 and ø 16

15 - 25 - 50 - 75 - 80 - 100 - 150 - 160 - 200 - 250 - 300 mm

ø 20 and ø 25

15 - 25 - 50 - 75 - 80 - 100 - 150 - 160 - 200 - 250 - 300 - 320 - 350 - 400 mm

ø 32

15 - 25 - 50 - 75 - 80 - 100 - 150 - 160 - 200 - 250 - 300 - 320 - 350 - 400 - 450 - 500 mm

Minimum and maximum springs load

Bore	Ø8	Ø10	Ø12	Ø16	Ø20	Ø25	Ø32
Min. load(N)	2.2	2.2	4	7.5	11	16.5	23
Max. load(N)	4.2	4.2	8.7	21	22	30.7	52.5

Basic version

Ordering code	Description
1280.Ø.stroke	Basic version STD
1291.Ø.stroke	Basic version front spring (max stroke 50 mm) STD
1292.Ø.stroke	Basic version rear spring from Ø16 (max stroke 50 mm)
12--Ø.stroke.A	Adjustable cushioning (from Ø16)
12--Ø.stroke.M	Magnetic piston STD
12--Ø.stroke.A.M	Cushioning with magnetic piston (from Ø16) STD
12--Ø.stroke. . . .T	HNBR seals version
12--Ø.stroke. . . .V	FPM seals version



Standard version, fully compliant with ISO standards. Can use all available mountings. For single acting type, the maximum stroke is 50 mm., after which overall dimensions increase in length to an extent not proportional to the stroke (and in any case not longer than stroke 100).

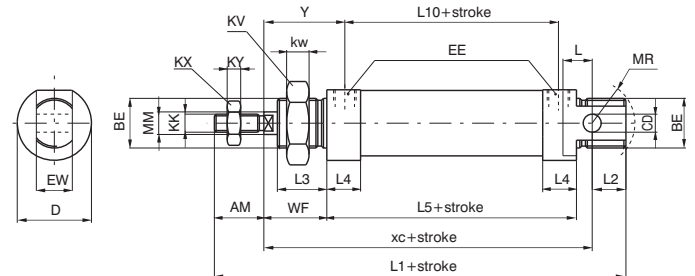

(Table of dimensions see page 2.40.04)

Push/Pull rod version (through rod)

Ordering code	Description
1282.Ø.stroke	Push/pull rod version
1282.Ø.stroke.M	Magnetic piston
1282.Ø.stroke.A	Adjustable cushioning (from Ø16)
1282.Ø.stroke.A.M	Cushioning with magnetic piston (from Ø16)
1282.Ø.stroke. . . .T	HNBR seals version
1282.Ø.stroke. . . .V	FPM seals version



This version having rods coming out from both end plates with overall dimensions, except for the rod, equal to 1280 version. This version is not suitable for Ø8 and Ø10 due to difficulty in anchoring the pistons to rods.

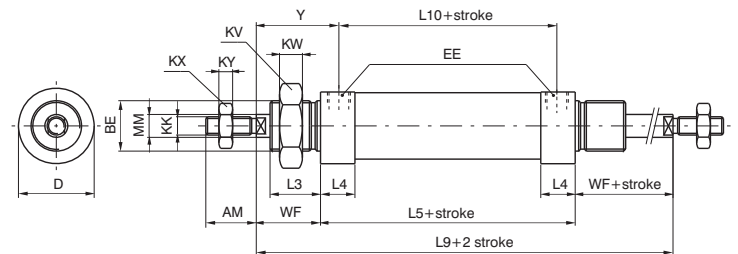

(Table of dimensions see page 2.40.04)



Table of dimensions

	Bore							
	8	10	12	16	20	25	32	
AM (-0,2)	12	12	16	16	20	22	20	
BE	M12X1,25	M12X1,25	M16X1,5	M16X1,5	M22X1,5	M22X1,5	M30X1,5	
CD (H9)	4	4	6	6	8	8	12	
D (h11)	16	16	20	21	27	30	38	
EE	M5	M5	M5	M5	G1/8"	G1/8"	G1/8"	
EW (d13)	8	8	12	12	16	16	26	
KK (6g)	M4X0,7	M4X0,7	M6X1	M6X1	M8X1,25	M10X1,25	M10X1,25	
KV	17	17	22	22	30	30	42	
KW	5,5	5,5	6	6	7	7	8	
KX	7	7	10	10	13	17	17	
KY	3	3	4	4	5	6	6	
L	6	6	9	9	12	13	13	
L1 (±1) *	86	86	105	111	130	141	139	
L2	10	10	14	13	15	15	14	
L3	12	12	17	17	18	22	22	
L4	9	9	9	11	15,5	15	14,5	
L5 (±1) *	46	46	50	56	68	69	69	
L6 *	48	48	52	58	70,5	71,5	71,5	
L7	2	2	2	2	2,5	2,5	2,5	
L8 *	64	64	74	80	94,5	99,5	99,5	
L9 (±1,2) *	78	78	94	100	116	125	125	
L10 (±1) *	37	37	41	45	52,5	53	54,5	
L11	1,5	1,5	1,5	1,5	2	2	2	
MM (f7)	4	4	6	6	8	10	12	
MR	12	12	16	16	18	19	22	
WF (±1,2)	16	16	22	22	24	28	28	
XC (±1) *	64	64	75	82	95	104	105	
Y (±1,2)	20,5	20,5	26,5	27,5	32	36	35	
Stroke tolerance: until stroke 100 +1,5 mm, beyond +2 mm								
Weight	stroke 0	30	35	65	80	160	200	310
gr.	every 10mm	2	2,5	4	5	7,5	11,5	18
Variations of the versions: <i>without rear eye version</i>								
Weight	stroke 0	25	30	60	75	150	185	290
gr.	every 10mm	2	2,5	4	5	7,5	11,5	18
<i>Push/pull rod version</i>								
Weight	stroke 0	35	40	75	95	200	250	370
gr.	every 10mm	2,5	3	6	7	10,5	15,5	24

Dimensions marked with * do not increase proportionally to stroke for rear spring version (over 25 mm stroke).



Technical modifications keep in reserve !

(2020/10)

ISO Non-Rotating Microcylinders ø16÷25mm Series CDEM

CARATTERISTICHE GENERALI MAIN CHARACTERISTICS



6432



COSTRUZIONE CONSTRUCTION

Tubo Tube	AISI 304
Asta Piston rod	AISI 303
Testata Cover	Alluminio anodizzato Anodized Aluminium
Guarnizioni Seals	Poliuretano Polyurethane
Pistoni Pistons	Ottone Brass
Bronzina Bush	Bronzo sinterizzato Sinterized bronze

FUNZIONAMENTO OPERATION

Pressione di funzionamento Working pressure	Max 10 bar
Temperatura Temperature	-30°C + 80°C con aria secca -30°C + 80°C with dry air
Fluido Working fluid	Aria compressa filtrata lubrificata e non Filtered compressed air lubricated or not

VERSIONI DISPONIBILI AVAILABLE VERSION

CDEM...ES	Doppio effetto, magnetico	Double acting, magnetic
-----------	---------------------------	-------------------------

1 PISTON ROD NUT + 1 END-CAP NUT included

CORSE STANDARD STANDARD STROKES

DOPIO EFFETTO DOUBLE ACTING	ømm	10	25	40	50	80	100	125	160	200	250	300	320	400	500
	16	✓	✓	✓	✓	✓	✓	✓	✓	✓	✓				
20	✓	✓	✓	✓	✓	✓	✓	✓	✓	✓	✓	✓	✓		
25	✓	✓	✓	✓	✓	✓	✓	✓	✓	✓	✓	✓	✓	✓	✓



Technical modifications keep in reserve !

(2020/10)

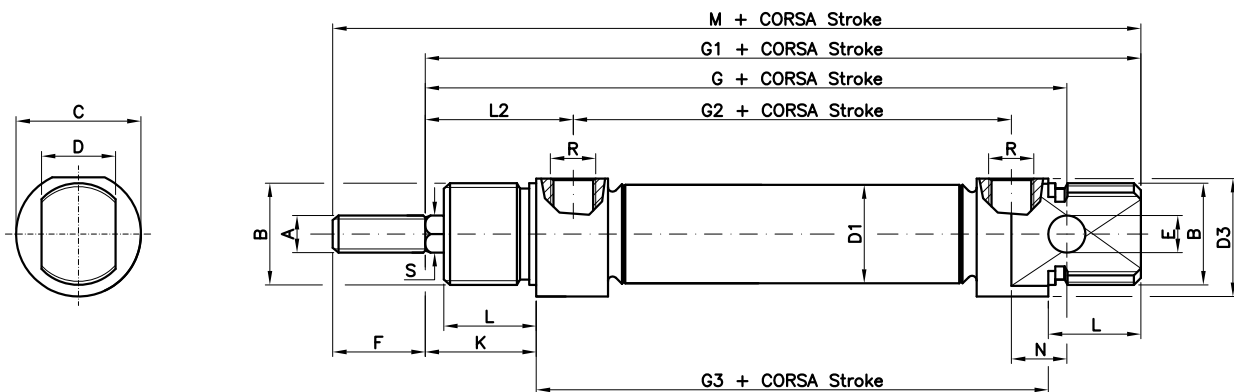

DIMENSIONI DIMENSIONS

ømm	A	S	B	C	D	D1	D3	E	F	G	G1	G2	G3	K	L	L2	N	R	M
16	M6	6	M16x1.5	19	12	17.27	18	6	16	82	93	43	53	22	18	27	9	M5	109
20	M8	8	M22x1.5	27	16	21.27	25.5	8	20	95	111	51.5	67	24	20	32	12	1/8"G	131
25	M10x1.25	10	M22x1.5	30	16	26.5	28.5	8	22	104	118	52	68	28	22	36	12	1/8"G	140

FORZE DI TRAZIONE E SPINTA (6 bar) TRACTION AND THRUST FORCES (6 bar)

ømm	FORZA DI SPINTA (N) THRUST FORCE (N)	FORZA DI TRAZIONE (N) TRACTION FORCE (N)
16	105	88
20	165	141
25	266	219

Codice esempio Order code example	CDEM25/50 ES
Tipo Type	CDEM...ES
Diametro Diameter	25
Corsa Stroke	50



Foot

Ordering code

1200.Ø.01
(1 piece)

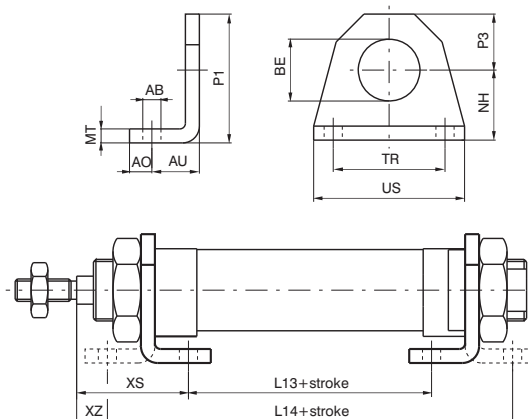

Used to mount the cylinder on the mounting plane with the rod parallel to said plane. Use one for short strokes and two for long strokes. It is made of stamped steel, made corrosion resistant by cataphoresis treatment. Attached to the end plates by means of nuts (or lock nuts) 05.

Attention: the dimensions of microcylinders with threaded end covers (★) increase of 10 mm. for microcylinders equipped with magnetic piston and spring return, and of 9 mm. for microcylinders with 10 mm. BORE magnetic piston.

Bore	8	10	12	16	20	25	32	40	50
AB (H13)	4,5	4,5	5,5	5,5	6,5	6,5	6,5	8,5	8,5
AO	5	5	6	6	8	8	8	10	10
AU	11	11	14	14	17	17	17	20	20
BE	12	12	16	16	22	22	30	40	40
L13 (±1) ★	30	30	30	36	44	45	45	49	52
L14 (±1) ★	68	68	78	84	102	103	103	119	122
MT	3	3	4	4	5	5	5	5	5
NH (±0,3)	16	16	20	20	25	25	28	40	40
P1	26	26	33	33	45	45	50	70	70
P3	10	10	13	13	20	20	22	30	30
TR (JS14)	25	25	32	32	40	40	52	70	70
US	35	35	42	42	54	54	66	90	90
XS (±1,4)	24	24	32	32	36	40	40	50	50
XZ (±1,4)	5	5	8	8	7	11	11	15	15
Weight gr.	22	22	45	45	90	90	110	210	210

Flange

Ordering code

1200.Ø.02
(1 piece)

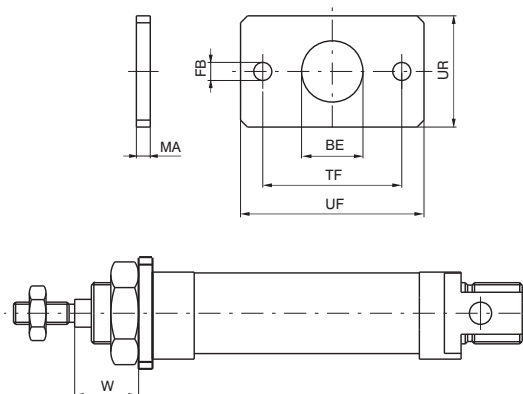

Used to mount the microcylinder at a right angle to the mounting plane. Attached to the front (or rear) endcap by a nut (or lock nut) 05. Made of extruded steel, made corrosion resistant by cataphoresis.

Bore	8	10	12	16	20	25	32	40	50
BE (H13)	4,5	4,5	5,5	5,5	6,5	6,5	6,5	8,5	8,5
UF	40	40	53	53	66	66	68	90	90
UR	25	25	30	30	40	40	50	60	60
MA	3	3	4	4	5	5	5	5	5
TF (JS14)	30	30	40	40	50	50	52	70	70
W (±1,4)	13	13	18	18	19	23	23	30	30
Weight gr.	20	20	40	40	85	85	100	150	150

Rear eye

Ordering code

1200.Ø.03
(1 piece)

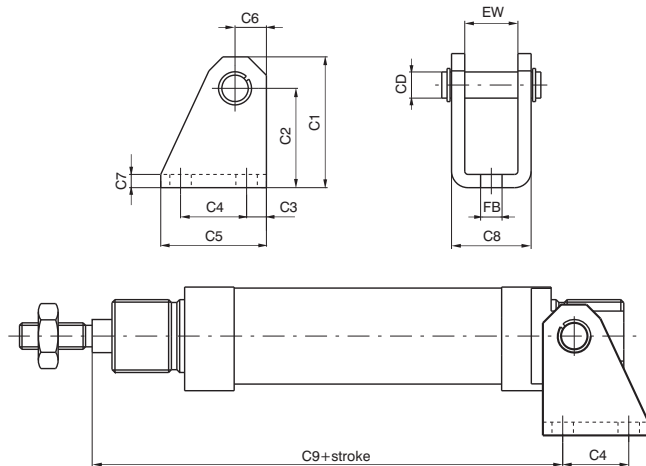

Use with the rear end cover to mount the cylinder either parallel or at a right-angle to the mounting plane. This allows the cylinder to oscillate and self-align with the linked element to the rod. This is necessary when the rod may be subject to lateral during travel.

Attention: the dimensions of microcylinders with threaded end covers (*) increase by 10mm for equipped with magnetic piston and spring return, and by 9mm for microcylinders with 10mm BORE magnetic piston.

Bore	8	10	12	16	20	25	32	40	50
CD	4	4	6	6	8	8	12	14	14
C1	28,5	28,5	33,5	33,5	39,5	39,5	44,5	53,5	53,5
C2 (±0,3)	24	24	27	27	30	30	33	40	40
C3	3,5	3,5	5	5	6	6	7	10	10
C4	12,5	12,5	15	15	20	20	24	28	28
C5	20	20	25	25	32	32	38	45	45
C6	4,5	4,5	6,5	6,5	9,5	9,5	11,5	13,5	13,5
C7	2,5	2,5	3	3	4	4	4	4	4
C8	13	13	18	18	24	24	34	38	38
C9 (±0,4) ★	63	63	73,5	80,5	91,5	100,5	100,5	119,5	122,5
EW	8,1	8,1	12,1	12,1	16,1	16,1	26,1	30,1	30,1
FB (H13)	4,5	4,5	5,5	5,5	6,5	6,5	6,5	8,5	8,5
Weight gr.	20	20	35	35	75	75	135	180	180



Cylinder rod forks / Nut or lock nut for the endcaps

Ordering code

1200.Ø.04 *
(with pin)

1200.Ø.04/1
(with clips)

*Available from bore Ø12

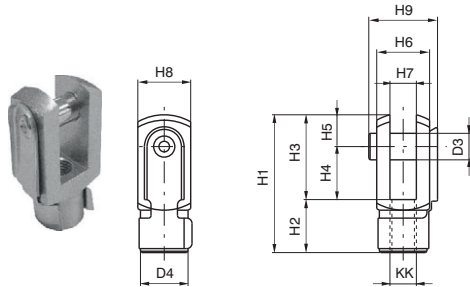
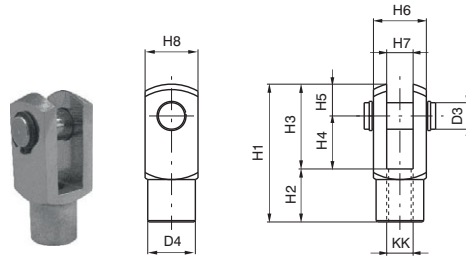

Forks:

Similar to hinge 03, mounted on the rod thread, assures a regular operation even in the presence of significant forces to the linked element. Made of zinc plated steel.

Nut:

Used to fasten flanges or feet to the endcaps of the microcylinder. The nuts are mounted on BOREs that go from 8 to 25, the lock nuts on 32, 40 and 50. Both are supplied (one piece) with the microcylinders.

Ordering code

1200.Ø.05

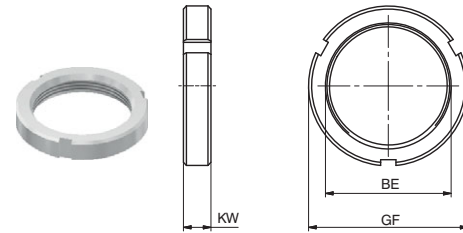
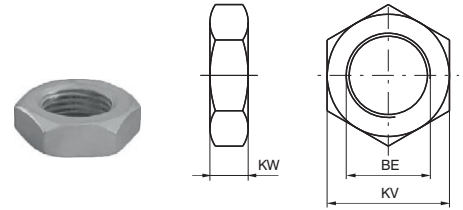

Bore	D3	D4	H1	H2	H3	H4	H5	H6	H7 (B12)	H8	H9	KK	BE	KV	GF	KW	Forks weight gr.	Nut weight gr.
8	4	8	21	8	13	8	5	8	4	10	11	M4x0,7	M12x1,25	17	-	5,5	12	7
10	4	8	21	8	13	8	5	8	4	10	11	M4x0,7	M12x1,25	17	-	5,5	12	7
12	6	10	31	12	19	12	7	12	6	12	18	M6x1	M16x1,5	22	-	6	20	16
16	6	10	31	12	19	12	7	12	6	12	18	M6x1	M16x1,5	22	-	6	20	16
20	8	14	42	16	26	16	10	16	8	16	23	M8x1,25	M22x1,5	30	-	7	45	25
25	10	18	52	20	32	20	12	20	10	20	27	M10x1,25	M22x1,5	30	-	7	90	25
32	10	18	52	20	32	20	12	20	10	20	27	M10x1,25	M30x1,5	-	42	8	90	42
40	12	20	62	24	38	24	14	24	12	24	32	M12x1,75	M40x1,5	-	52	9	145	60
50	12	20	62	24	38	24	14	24	12	24	32	M12x1,75	M40x1,5	-	52	9	145	60

Articulated clevis in self-lubricating zinc-plated steel

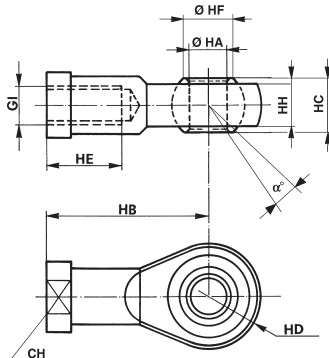

Cyl. Ø	α°	CH	KK	HA	HB	HC	HD	HE	HF	HH	Weight-Mass (g.)	Part no.
				H7								
8-10	13°	9	M4 X 0.7	5	27	8	9	10	7.7	6	18	MF - 17008
12-16	13°	11	M6 X 1	6	30	9	10	12	9	6.8	26	MF - 17012
20	14°	14	M8 X 1.25	8	36	12	12	16	10.4	9	46	MF - 17020
25	13°	17	M10 X 1.25	10	43	14	14	20	12.9	10.5	76	1320.32.32F



Miniaturised magnetic sensors Rectangular section



Sensor with 2.5 m. cable



Weight gr. 27

Sensor with cable and M8 connector



Weight gr. 15

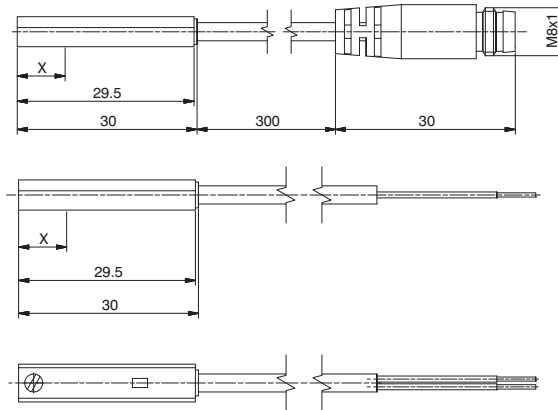

X= point of commutation

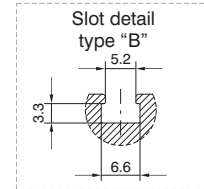

Sensor ordering codes

Ampulla Reed sensors, with led, Universal, N.O. (Normally open)			X=point of commutation
1580.U	(2 wires) cable 2.5 mt.	15 mm	STD
MRS.U	(2 wires) cable 300 mm, M8 connector (use MC1 or MC2 connectors)	15 mm	STD
1580.UAP	PNP (3 wires) cable 2.5 mt.	15 mm	STD
MRS.UAP	PNP (3 wires) cable 300 mm, M8 connector (use MCH1 or MCH2 connectors)	15 mm	

Hall effect sensors, with led, DC, N.O. (Normally open)			X=point of commutation
1580.HAP	PNP (3 wires) cable 2.5 mt.	8 mm	STD
1580.HAN	NPN (3 wires) cable 2.5 mt.	8 mm	
MHS.P	PNP (3 wires) cable 300 mm, M8 connector (use MCH1 or MCH2 connectors)	8 mm	STD

Diagrams and connections

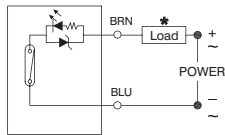

with Reed bulb (2 wires)

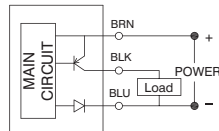

Hall-PNP effect (3 wires)

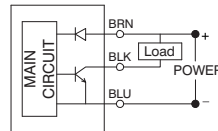

Hall-NPN effect (3 wires)

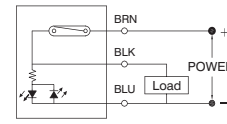

with Reed bulb (3 wires)

* The load (LOAD) can be connected either to negative or positive pole

Technical characteristics	1580.U	MRS.U	1580.UAP	MRS.UAP	1580.HAP	1580.HAN	MHS.P
Type of contact	N.O.						
Output type				PNP		NPN	PNP
Maximum current				100mA			
Maximum permanent power	14 VA - 10 W		4 VA - 3 W		3 W		
Voltage range	5 - 230V DC/AC	5 - 30V DC/AC	10 - 30 V DC/AC		10 - 30 V DC		
Working temperature	-10°C - +70°C						
Maximum voltage drop	3.5 V		0V **		2 V		
Cable section (mm ²)	2 x 0.14 Ø3.3mm PUR	2 x 0.14 Ø3.3mm PUR	3 x 0.14 Ø3.3 mm PUR		3 x 0.14 Ø3.3 mm PUR		
Degree of protection	IP 67						

** Even if one sensor generates a voltage drop very close to 0 Volts, we suggest to connect no more than 30 sensors in series.

Cable ordering code

Connection 2 wires

- MC1** cable 2 wires l=2.5m with M8 connector
- MC2** cable 2 wires l=5m with M8 connector
- MC3** cable 2 wires l=10m with M8 connector



- 1 Brown (+)
- 4 Blue (-)
- 3 Not use

Connection 3 wires

- MCH1** cable 3 wires l=2.5m with M8 connector **STD**
- MCH2** cable 3 wires l=5m with M8 connector
- MCH3** cable 3 wires l=10m with M8 connector



- 1 Brown (+)
- 4 Black (signal)
- 3 Blue (-)

Magnetic sensors
REED style with 2 m cable

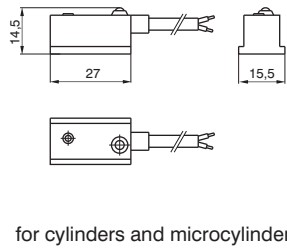
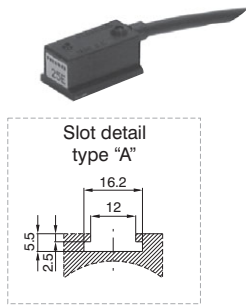

for rodless cylinders

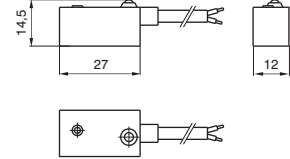

Diagrams and connections

Ordering code

SENSORS WITH 2 WIRES CABLE (PUR Ø4.2 mm 2 x 0.34mm²)

Cylinders and microcylinders	1500.AC	sensor for alternating current with led	STD
	1500.DC	sensor for continuous current with led	
	1500. U	universal sensor with led	
	1500.U/1	universal sensor without led (REED ampulla only)	
Rodless cylinders	1600.AC	sensor for alternating current with led	
	1600.DC	sensor for continuous current with led	
	1600.U	universal sensor with led	
	1600.U/1	universal sensor without led (REED ampulla only)	

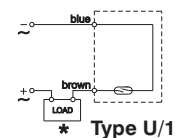
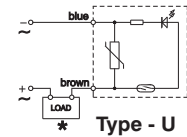
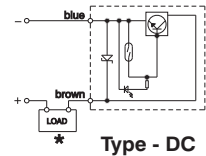
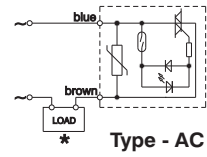

Technical characteristics	A.C.	D.C.	U		U/1	
			a.c.	d.c.	a.c.	d.c.
Maximum permanent current	1,5A	1,2A	0,5A		0,3A	
Maximum current (pulses of 0,5 sec.)	6A	1,5A	1A		0,8A	
Voltage range	12 - 230V	12 - 30V	3 - 230V	12 - 48V	0 - 230V	0 - 48V
Maximum permanent power	375VA	32W	20VA	15W	10VA	8W
Working temperature	-20° C - 70° C					
Maximum voltage drop	3V max	2V max	3V max		0V	
Cable section	2x0,34 mm ² Ø4,2 mm PUR					
Degree of protection	IP 65					
Connecting time	2 ms					
Disconnecting time	1 ms					
Average working period	10 ⁷ cycles					
Repetition of intervention point	± 0,1 mm					
Type of contact	N.O.					

*The load (LOAD) can be connected either to negative or positive pole.

These sensors can be used on cylinders series:

SERIES	DESCRIPTION	MOUNTED
1200	for microcylinders with threaded end covers and "TECNO-MIR" microcylinders	with clamps code 1260.Ø.F
	for microcylinders "MIR" with rolled end covers, cylinders from Ø16 to Ø32	with clamps code 1280.Ø.F
1306 - 1307 - 1308	for microcylinders "MIR-INOX" with rolled end covers	with clamps code 1280.Ø.FX
	for cylinders from Ø32 to Ø63	with brackets code 1306.A
	for cylinders from Ø80 to Ø125	with brackets code 1306.B
1315	for cylinders from Ø160 to Ø200	with brackets code 1306.C
	for cylinders Ø250 and Ø320 (ISO)	with brackets code 1306.D
	for cylinders Ø32 and Ø40	with brackets code 1320.A
1319 - 1320	for cylinders Ø50 and Ø63	with brackets code 1320.B
	for cylinders Ø80 and Ø100	with brackets code 1320.C
	for cylinders Ø125	with brackets code 1320.D
	for cylinders Ø160	with brackets code 1320.E
	for cylinders Ø200	with brackets code 1320.F
	for cylinders ECOLIGHT Ø32 and Ø40	with brackets code 1390.A
1390 - 1391	for cylinders ECOLIGHT Ø50 and Ø63	with brackets code 1390.B
	for cylinders ECOLIGHT Ø80 and Ø100	with brackets code 1390.C
	for cylinders ECOLIGHT Ø125 - Ø200	with brackets code 1390.D
	for cylinders ECOLIGHT Ø125 - Ø200	with brackets code 1390.D
1500	Compact cylinders "Europe" (from Ø32)	directly on groove
1605	Rodless cylinders	with brackets code 1600.A

Technical modifications keep in reserve !

(2020/10)

Sensor clamps - codes 1500._, RS._, HS._	Sensor clamps - codes 1580._, MRS._, MHS._
Ordering code	Ordering code
1280.Ø.F - cylinders MIR 1280.Ø.FX - cylinders MIR-INOX	1280.Ø.FS - cylinders MIR 1280.Ø.FSX - cylinders MIR-INOX

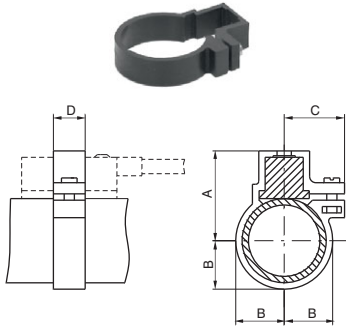

Table of dimensions

Bore	Ø16	Ø20	Ø25	Ø32
A	24	25,5	28,5	31,8
B	10,5	12,5	15,5	18,8
C	16,5	17,5	19	20
D	10	10	10	10
Weight (gr)	3	5	7	10

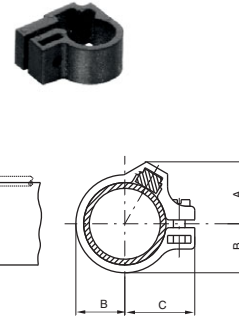

Table of dimensions

Bore	Ø8	Ø10	Ø12	Ø16	Ø20	Ø25	Ø32
A	11	12	13	14,5	16	17,5	19,5
B	6,5	7,5	8,5	10,5	12,5	15,3	18,8
C	12,5	13,5	15	16	18	20,5	24
D	10	10	10	10	10	10	10
Weight (gr)	2	2	2	3	5	7	10





Construction characteristics

Body	extruded shape anodized aluminium alloy 6060
Bushings	sintered bronze
Wiper	oil resitant NBR rubber
Rods	chromed C43 steel
Plate	plated zinc steel
Mounting block	plated zinc steel

Technical characteristics

Max. suggested strokes for 1200 series:

Diameter	20	25
Stroke mm	200	250

Loading diagram based on dimension "A"

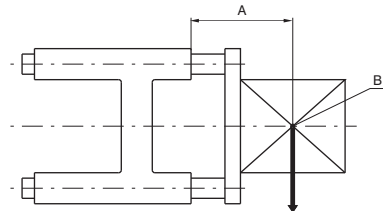

A = Protusion
B = Load centre of gravity

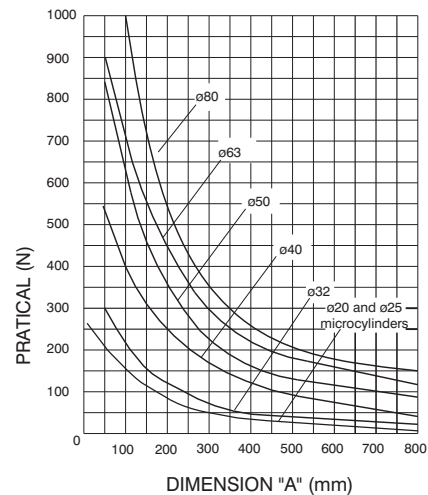

Use and maintenance

Follow the indication of the above diagram as far as loads are concerned. A large quantity of grease is placed between the two wipers during assembly, therefore the linear control units should not require special maintenance.

Dimensions for microcylinders ISO 6432

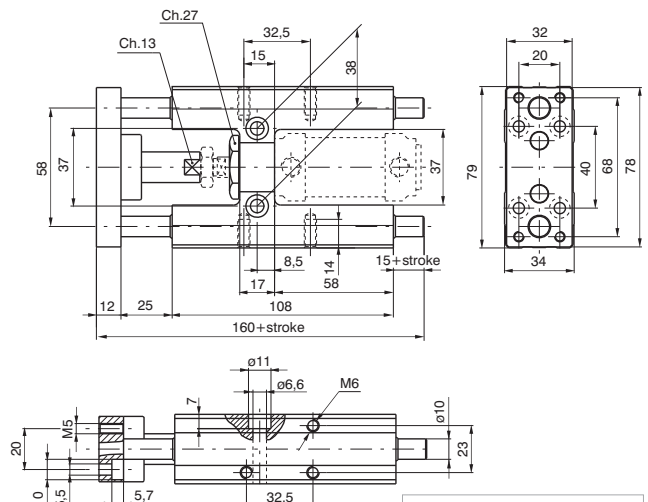
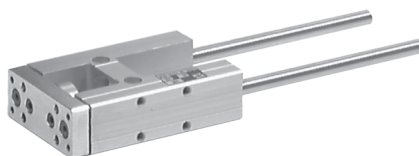

Example code
1280.25.050.GLB

(Microcylinder
1280.25.050.AM included)

Standard strokes

Ø25 50 - 75 - 80 -100 - 125 - 150 - 160 -200 mm

Weight gr.	
stroke 100	every 50 mm
970	60

Sensors and sensor clamps: Use standard sensors and clamps.

Technical modifications keep in reserve !

(2020/10)



General

The piston rod lock devices are clamping units mounted on the microcylinders front head. They allow the piston rod to lock in any position.

Piston rod clamping is mechanically obtained by springs actuated purpose-made jaws. This method allows to lock the cylinder in the desired position, should the air pressure drop.

The piston rod lock device is not a safety device.

Construction characteristics

Mounting bracket	anodised aluminium
Body	anodised aluminium
Clamping jaws	hardened alloy copper
Piston	acetal resin
Seal	NBR Oil resistant rubber
Springs	springs steel

Technical characteristics

Fluid	filtered and lubricated air						
Working pressure	3 bar - 6 bar						
Working temperature	-5°C - +70°C						
Functioning	mechanical double jaws						
Locking	axial, two-direction (normally locked)						
Unlocking	pneumatic						
Clamping force with static load (microcylinders)	Ø12 180N	Ø16 180N	Ø20 350N	Ø25 350N	Ø32 600N		
Clamping force with static load (cylinders)	Ø32 600N	Ø40 1000N	Ø50 1400N	Ø63 2000N	Ø80 5000N	Ø100 5000N	Ø125 7000N

"Attention: Dry air must be used for application below 0°C"

Use and maintenance

Operate within the specified technical characteristics.

The piston rod lock does not require maintenance if properly utilised.

The working inlet port has to be pressurised for assembling the piston rod lock device on cylinder. Alternatively adjust the jaws with screw located on connection.

Spare parts are not available.

Microcylinders for piston rod lock

Threaded end covers version

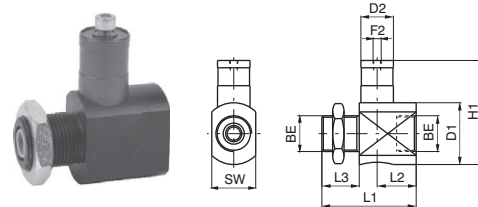
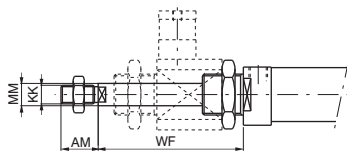

Ordering code
12_ _Ø.stroke.B

Order piston rod lock separately. Do not use with stainless steel or hexagonal piston rod.

Ordering code
1260.Ø.51BS

Ø	12	16	20	25	32
Weight gr.	82	82	140	140	188

Table of dimensions (series 1200)

Bore	AM	BE	D1	D2	F2	H1	H3	H4	H5	H6	KK	L1	L2	L3	MM	SW	WF
12	16	M16x1.5	20	16	M5	35	35	10	11	10	M6x1	42	21	12	6	20	55
16	16	M16x1.5	20	16	M5	35	35	10	11	10	M6x1	42	21	12	6	20	55
20	20	M22x1.5	38	20	M5	64	62	17.5	19	18	M8x1.25	58	24	23	8	27	73
25	22	M22x1.5	38	20	M5	64	62	17.5	19	18	M10x1.25	58	24	23	10	27	77
32	20	M30x1.5	39.5	20	M5	64	62	17.5	18.5	18	M10x1.25	60	26	22	12	35	76.5