

COMPACT CYLINDERS $\varnothing 16 \div 63$ mm

Series RP, RS, RQ

1. COMPACT CYLINDERS series UNITOP (RP)

Working pressure: 1,5 ÷ 10 bar
 Ambient temperature: -20 ÷ +80°C
 Fluid: lubricated or non lubricated air
 Barrel: extruded aluminium alloy with piston rod in chromium-plated steel or stainless steel
 Magnetic version
 The octagonal version with female piston rod is standard supplied with assembled flange
 Max. speed: 1 m/s

Upon request

- Hollow piston rod only for through piston rod versions.
- Magnetic sensor DF-series (see page 2.27)
- Wire protection strap for magnetic sensor, part n. DHF-002100.

Codification Key

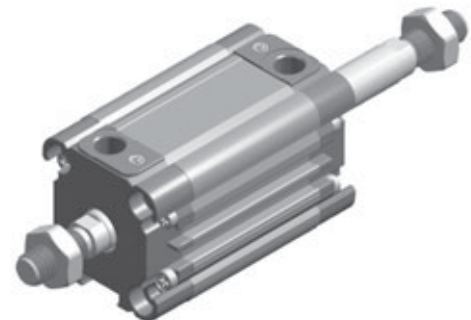
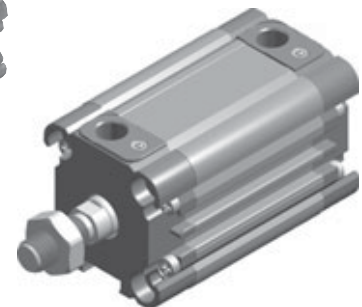
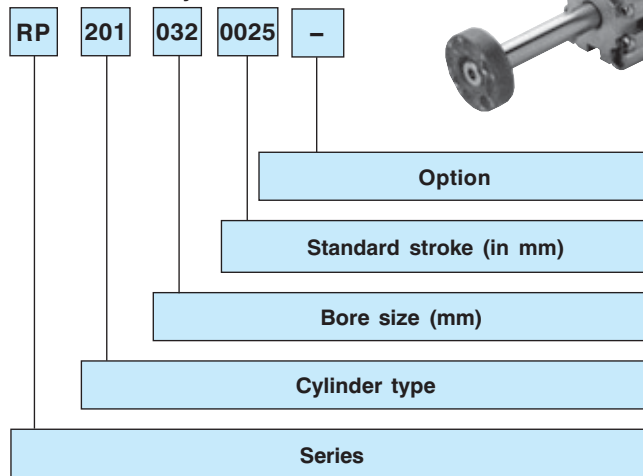

SERIES

Round cylinder barrel

RP series – compact UNITOP RU – P/7 $\varnothing 16 \div 63$ mm

RM series – compact ISO 21287 $\varnothing 16 \div 63$ mm

Octagonal cylinder barrel

RO series – compact UNITOP RU - P/7 $\varnothing 16 \div 63$ mm

RN series – compact ISO 21287 $\varnothing 16 \div 63$ mm

TYPE

1... with female piston rod in stainless steel RP – RO series

2... with female piston rod in chromium-plated steel RP – RO series

-00 D.A.

-01 D.A. through rod

-10 D.A. non-rotating rod (only RP series)

-11 D.A. non-rotating through rod (only RP series)

-20 D.A. extended piston (32 ÷ 63 mm)

-60 S.A. retracted rod (only RP series)

-70 S.A. extended rod (only RP series)

3... with male piston rod in stainless steel RM – RN series

4... with male piston rod in chromium-plated steel RM – RN series

-00 D.A.

-01 D.A. through rod

-20 D.A. extended piston (32 ÷ 63 mm)

-60 S.A. retracted rod (only RM series)

-70 S.A. extended rod (only RM series)

BORE

016 – 020 – 025 – 032 – 040 – 050 – 063 mm

STANDARD STROKE

Single acting

0005-0010 mm (16 ÷ 25 mm)

0015-0020-0025 mm ($\varnothing 32 \div 63$ mm)

Double acting

0005-0010-0015-0020-0025-0030-0040-0050-0060-0080 mm

Max. standard stroke

$\varnothing 16$ 0040 mm

$\varnothing 20-25$ 0050 mm

$\varnothing 32-63$ 0080 mm

Max. stroke with guided piston rod (upon request)

$\varnothing 16$ 0100 mm

$\varnothing 20-25$ 0200 mm

$\varnothing 32-40$ 0400 mm

$\varnothing 50-63$ 0500 mm

OPTION

C = with flange for RP series versions 200/201/260/270 and 100/101/160/170

H = hollow rod only for versions with through rod, without flange

Construction details

- Barrel in extruded aluminium alloy, externally and internally anodized 15 μm , plain profile, for flush-mounted sensors
- Die-cast end-caps in zamac ($\varnothing 16 \div 25 \text{ mm}$); in aluminium alloy ($\varnothing 32 \div 63 \text{ mm}$)
- Self-tapping screws in zinc-plated steel
- Chromium-plated steel rod
- Stainless steel rod
- Piston in aluminium
- Acetal resin slide
- Piston seals in nitrile rubber
- Rod seals in polyurethane
- Piston in aluminium D.A.

- Extended piston D.A. for supporting a higher radial load ($\varnothing 32 \div 63 \text{ mm}$)

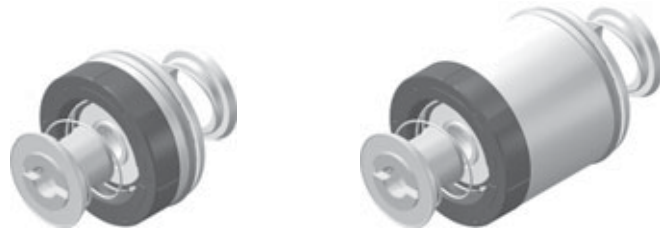

Nominal tolerances on stroke

Cyl. \varnothing	Tolerance mm
16 \div 25	+ 1,5/0
32 \div 50	+ 2/0
63	+ 2,5/0

- Adjustable pneumatic cushioning for efficient deceleration of the piston and reduced noise level.
- Cushioning length 8 mm ($\varnothing 16 \div 25 \text{ mm}$); 10 mm ($\varnothing 32 \div 63 \text{ mm}$).

Theoretical forces [N] developed at the working pressure [bar]

Cyl. \varnothing	Working area [mm ²]		Working pressure [bar]					Max. applicable torque [Nm] for RO/RN series with non-rotating rod	
			2	4	6	8	10	Cyl. \varnothing	Torque [Nm]
16	Thrust	201	40	80	121	161	201	16	0,5
		151	30	60	91	121	151		
20	Thrust	314	63	126	188	251	314	20	0,8
		236	47	94	142	189	236		
25	Thrust	491	98	196	295	393	491	25	1
		412	82	165	247	330	412		
32	Thrust	804	161	322	482	643	804	32	2
		691	138	276	414	553	691		
40	Thrust	1256	251	502	754	1005	1256	40	3
		1143	228	457	685	914	1143		
50	Thrust	1962	393	785	1178	1570	1963	50	5
		1762	352	704	1057	1409	1762		
63	Thrust	3116	623	1246	1869	2493	3116	63	8
		2916	583	1166	1749	2332	2916		

In case of pneumatic cylinders with through rod, the theoretical force to be considered, in both directions, is always equal to the "traction" value indicated in the table.

For practical purposes these values should be reduced taking into account the weight and sliding friction of the mobile equipment (~ -10%).

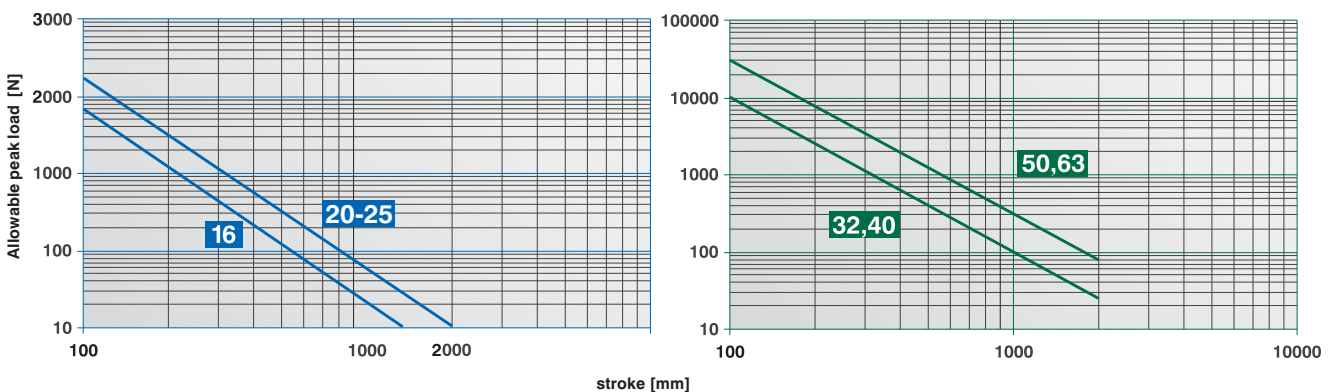

Double-acting cylinder RP 200... / RP 220...* series with extended piston

Ø 16 ÷ 25 mm

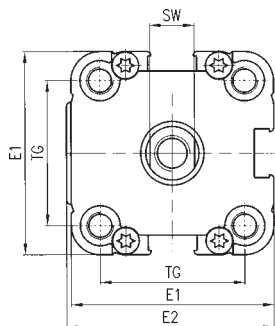

Ø 32 ÷ 63 mm

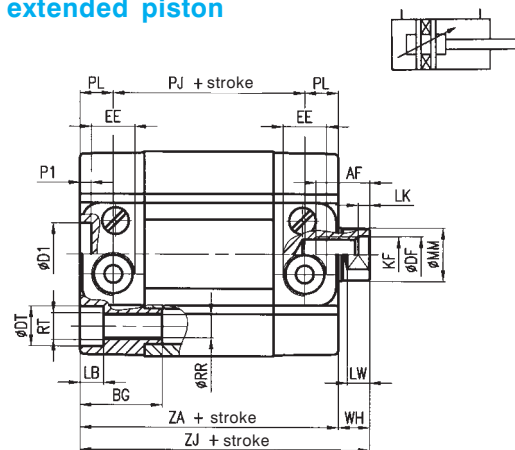
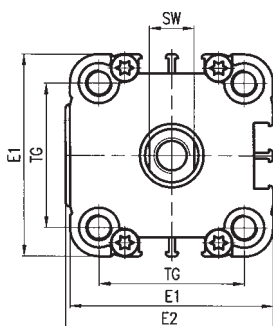

Mass RP 200...

Cyl. Ø	Cylinder stroke "0" (g)	Increase by mm stroke (g)	Moving parts stroke "0" (g)	Increase by mm stroke (g)
16	103	1,05	15,5	0,39
20	135	1,45	24,5	0,62
25	203	1,65	34,5	0,62

Mass RP 200.../RP 220...

Cyl. Ø	Cylinder stroke "0" (g)	Increase by mm stroke (g)	Moving parts stroke "0" (g)	Increase by mm stroke (g)
32	205/291,5	2,65	60/115,5	0,9
40	305/426	3,3	75/148	0,9
50	450/676,5	4,7	125/274	1,6
63	735/1063,5	5,65	200/427	1,6

Double-acting cylinder male piston rod RM 400.../RM 420...* series with extended piston

Ø 16 ÷ 25 mm

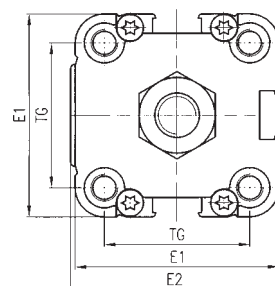

Ø 32 ÷ 63 mm

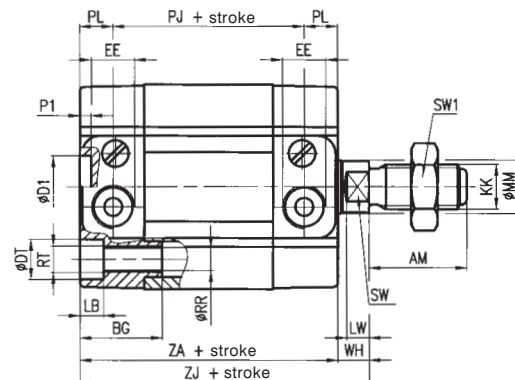
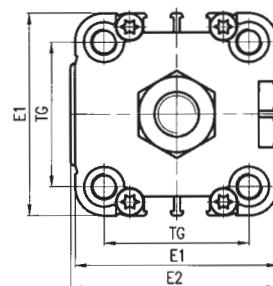

Mass RM 400...

Cyl. Ø	Cylinder stroke "0" (g)	Increase by mm stroke (g)	Moving parts stroke "0" (g)	Increase by mm stroke (g)
16	115	1,05	27,5	0,39
20	157	1,45	46,5	0,62
25	225	1,65	56,5	0,62

Mass RM 400.../RM 420...

Cyl. Ø	Cylinder stroke "0" (g)	Increase by mm stroke (g)	Moving parts stroke "0" (g)	Increase by mm stroke (g)
32	240/326,5	2,65	95/146,5	0,9
40	340/461	3,3	110/183	0,9
50	505/731,5	4,7	180/329	1,6
63	790/1198,5	5,65	255/482	1,6

▲ Only for RM series: dimensional variants for end-caps with ISO inter-axes: Ø 40 - 38 mm / Ø 50 - 46,5 mm / Ø 63 - 56,5 mm

Cyl. Ø	AF	AM	BG	ØD1 H11	Ø DF	Ø DT	E1	E2	EE	KF	KK	LB	LK	LW	Ø MM	P1	PJ	PL	Ø RR	RT	SW	SW1	TG	WH	ZA	ZJ
16	8	12	16	2	4,1	5,8	28	30	M5	M4	M6X1	3,2	1	4,5	8	2	21	8	3,2	M4	7	10	18	5	37	42
20	10	16	16	2	6,1	7,3	32	34	M5	M6	M8x1,25	4,2	1	4,5	10	2	21	8	4,2	M5	8	13	22	6	37	43
25	10	16	16	2	6,1	8	37	39	M5	M6	M8x1,25	4,5	1	4,5	10	2	23	8	4,2	M5	8	13	26	6	39	45
32	12	19	18	14	8,2	9	46	47	G1/8	M8	M10x1,25	5,3	2	5	12	2,5	29	7,5	5,2	M6	10	17	32,5	7	44	51
40	12	19	18	14	8,2	9	56	57	G1/8	M8	M10x1,25	5,3	2	5	12	2,5	30	7,5	5,2	M6	10	17	42	7	45	52
50	16	22	24	18	10,2	11	66	67	G1/8	M10	M12x1,25	6,5	2	6	16	2,5	30	7,5	6,5	M8	13	19	50	8	45	53
63	16	22	24	18	10,2	11	79	80	G1/8	M10	M12x1,25	6,5	2	6	16	2,5	34	7,5	6,5	M8	13	19	62	8	49	57

* For cylinder types with extended piston, dimensions PJ, ZA and ZJ will be increased by 20 mm (Ø 32-40 mm), and 25 mm (Ø 50-63 mm).

Double-acting cylinder, through rod RP 201 series

Ø 16 ÷ 25 mm

Ø 32 ÷ 63 mm

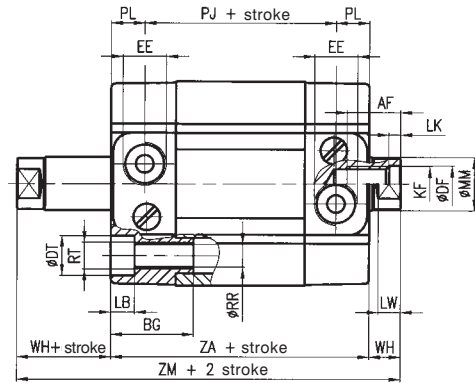
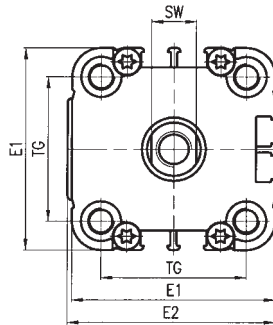
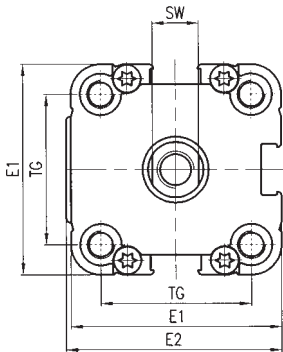
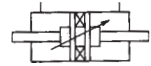

Double-acting cylinder with male through piston rod RP 401 series

Ø 16 ÷ 25 mm

Ø 32 ÷ 63 mm

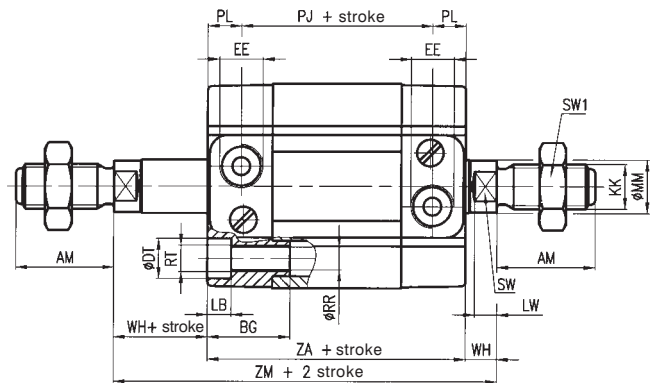
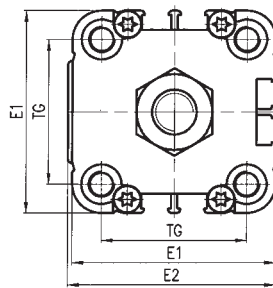
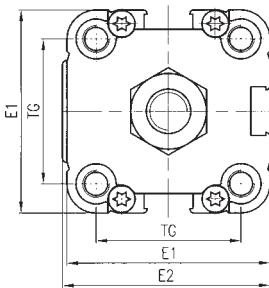

Series RP 201...

For version with hollow through piston rod, variant H in codification key:

Cyl. Ø	Hole mm
16	3,2
20-25	3,8
32-40	4,5
50-63	6

Mass RP 201...

Cyl. Ø	Cylinder stroke "0" (g)	Increase by mm stroke (g)	Moving parts stroke "0" (g)	Increase by mm stroke (g)
16	105	1,45	17,5	0,78
20	138	2,07	24,8	1,24
25	206	2,27	34,8	1,24
32	230	3,55	85	1,8
40	325	4,2	100	1,8
50	490	6,3	165	3,2
63	775	7,25	245	3,2

Mass RM 401...

Cyl. Ø	Cylinder stroke "0" (g)	Increase by mm stroke (g)	Moving parts stroke "0" (g)	Increase by mm stroke (g)
16	129	1,45	41,5	0,78
20	182	2,07	68,8	1,24
25	250	2,27	78,8	1,24
32	290	3,55	125	1,8
40	390	4,2	140	1,8
50	570	6,3	225	3,2
63	855	7,25	300	3,2

▲ Only for RM series: dimensional variants for end-caps with ISO inter-axes: Ø 40 - 38 mm / Ø 50 - 46,5 mm / Ø 63 - 56,5 mm

Cyl. Ø	AF	AM	BG	Ø DF	Ø DT	E1	E2	EE	KF	KK	LB	LK	LW	Ø MM	PJ	PL	Ø RR	RT	SW	SW1	TG	WH	ZA	ZM
16	8	12	16	4,1	5,8	28	30	M5	M4	M6X1	3,2	1	4,5	8	21	8	3,2	M4	7	10	18	5	37	47
20	10	16	16	4,1	7,3	32	34	M5	M6	M8X1,25	4,2	1	4,5	10	21	8	4,2	M5	8	13	22	6	37	49
25	10	16	16	4,1	8	37	39	M5	M6	M8X1,25	4,5	1	4,5	10	23	8	4,2	M5	8	13	26	6	39	51
32	12	19	18	8,2	9	46	47	G1/8	M8	M10x1,25	5,3	2	5	12	29	7,5	5,2	M6	10	17	32,5	7	44	58
40	12	19	18	8,2	9	56	57	G1/8	M8	M10x1,25	5,3	2	5	12	30	7,5	5,2	M6	10	17	42	7	45	59
50	16	22	24	10,2	11	66	67	G1/8	M10	M12x1,25	6,5	2	6	16	30	7,5	6,6	M8	13	19	50	8	45	61
63	16	22	24	10,2	11	79	80	G1/8	M10	M12x1,25	6,5	2	6	16	35	7,5	6,6	M8	13	19	62	8	50	66

Technical modifications keep in reserve !

(2009/09)

Double-acting cylinder with non-rotating device RP 210 ... series

Ø 16 ÷ 25 mm

Ø 32 ÷ 63 mm

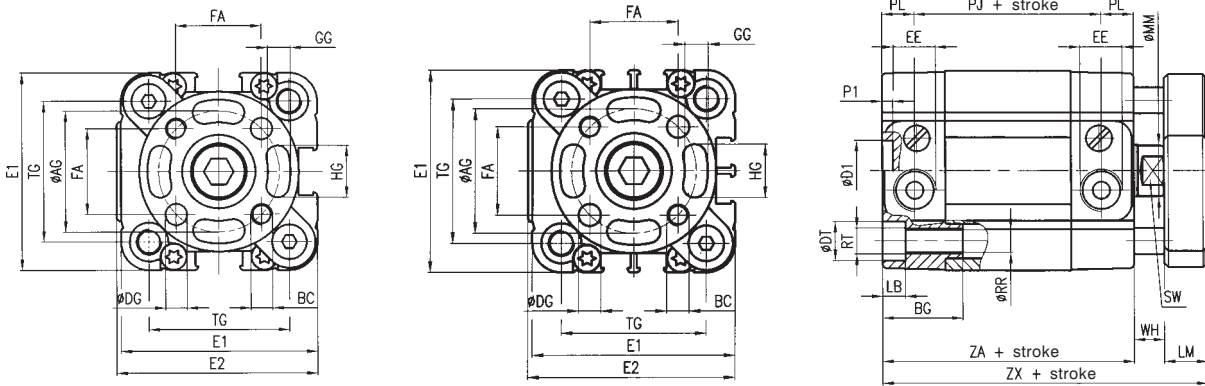
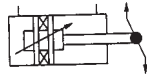

Double-acting cylinder, through rod with non-rotating device RP 211... series

Ø 16 ÷ 25 mm

Ø 32 ÷ 63 mm

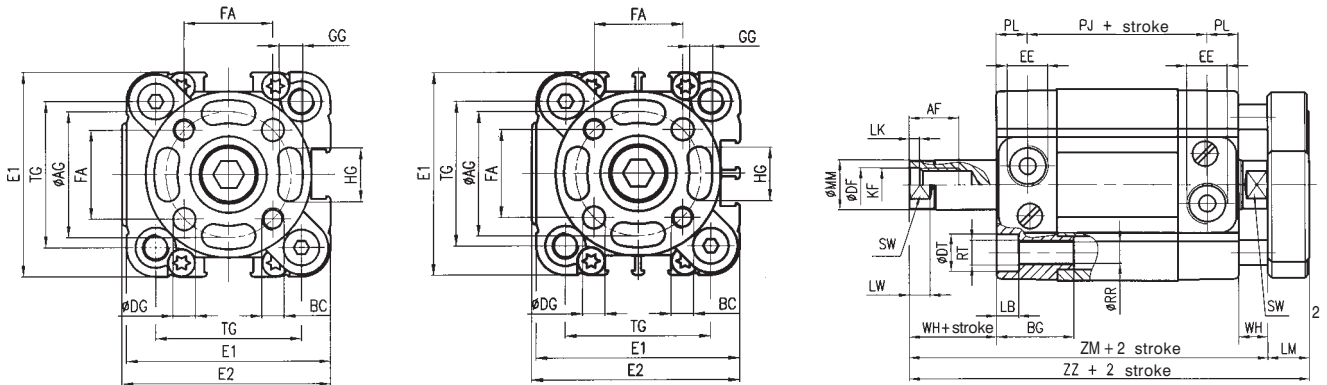

Mass RP 210...

Cyl. Ø	Cylinder stroke "0" (g)	Increase by mm stroke (g)	Moving parts stroke "0" (g)	Increase by mm stroke (g)
16	122	1,25	34,5	0,59
20	165	1,75	54,5	0,93
25	240	1,95	71,5	0,93
32	245	3,09	100	1,34
40	372	4,1	142	1,7
50	545	5,5	220	2,4
63	875	6,89	340	2,84

Mass RP 211...

Cyl. Ø	Cylinder stroke "0" (g)	Increase by mm stroke (g)	Moving parts stroke "0" (g)	Increase by mm stroke (g)
16	124	1,64	36,7	0,98
20	168	2,37	57,5	1,55
25	243	2,57	74,5	1,55
32	270	3,99	125	2,24
40	392	5	167	2,6
50	585	7,1	260	4
63	915	8,49	385	4,44

Cyl. Ø	AF	AG	BC	BG	Ø D1 D11	Ø DF	Ø DG	Ø DT	E1	E2	EE	FA	GG	HG	KF	LB	LM	LK	LW	Ø MM	P1	PJ	PL	RR	RT	SW	SW2	TG	WH	ZA	ZM	ZX	ZZ
16	8	14	M3	16	2	4,1	3	5,8	28	30	M5	9,9	3	5	M4	3,2	6	1	4,5	8	2	21	8	3,2	M4	7	-	18	5	37	47	48	53
20	10	17	M4	16	2	6,1	4	7,3	32	34	M5	12	4	7	M6	4,2	8	1	4,5	10	2	21	8	4,2	M5	8	-	22	6	37	49	51	57
25	10	22	M5	16	2	6,1	5	8	37	39	M5	15,6	5	9	M6	4,5	8	1	4,5	10	2	23	8	4,2	M5	8	-	26	6	39	51	53	59
32	12	28	M5	18	14	8,2	5	9	46	47	G1/8	19,8	5,2	11	M8	5,3	10	2	5	12	2,5	29	7,5	5,2	M6	10	17	32,5	7	44	58	61	68
40	12	33	M5	18	14	8,2	5	9	56	57	G1/8	23,3	5,2	15	M8	5,3	10	2	5	12	2,5	30	7,5	5,2	M6	10	19	42	7	45	59	62	69
50	16	42	M6	24	18	10,2	6	11	66	67	G1/8	29,7	6,2	19	M10	6,5	12	2	6	16	2,5	30	7,5	6,6	M8	13	24	50	8	45	61	65	73
63	16	50	M6	24	18	10,2	6	11	79	80	G1/8	35,4	6,2	25	M10	6,5	12	2	6	16	2,5	35	7,5	6,6	M8	13	24	62	8	50	66	70	78

Technical modifications keep in reserve !

(2009/09)

Front or rear flange in zinc-plated steel

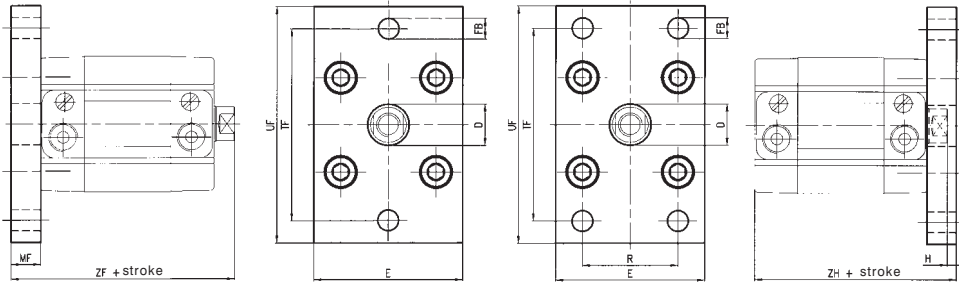

Cyl. Ø	Part num. / Mass for...	
	Unitop RU-P/7/Kg	ISO 21287/Kg
16	RPF-12016/0,10	
20	RPF-12020/0,16	
25	RPF-12025/0,20	
32	RPF-12032/0,26	KF-12032/0,20
40	RPF-12040/0,42	KF-12040/0,25
50	RPF-12050/0,60	KF-12050/0,50
63	RPF-12063/1,20	KF-12063/0,65

Angle bracket in zinc-plated steel

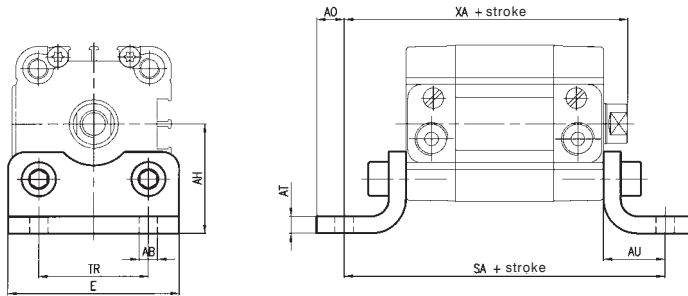

Cyl. Ø	Part num. / Mass for...	
	Unitop RU-P/7/Kg	ISO 21287/Kg
16	RPF-13016/0,02	
20	RPF-13020/0,03	
25	RPF-13025/0,04	
32	RPF-13032/0,07	KF-13032/0,07
40	RPF-13040/0,10	KF-13040/0,10
50	RPF-13050/0,15	KF-13050/0,15
63	RPF-13063/0,25	KF-13063/0,25

Flange

Bracket

Cyl. Ø	Ø D H11	E	Ø FB H13	H	MF	R Js14	TF Js14	UF	ZF	ZH	Ø AB H13	Ø AN Js15	AO	AT	AU	E	SA	TR	XA
16	10	29	5,5	5	10	-	43	55	52	47	5,5	22	4,5	3	13	30	63	18	55
20	12	36	6,6	4	10	-	55	70	53	47	6,6	27	6	4	16	36	69	22	59
25	12	40	6,6	4	10	-	60	76	55	49	6,6	30	6	4	16	40	71	26	61
32	14/30	50/45	7	3	10	32	65/64	80	61	54	6,6/7	32,25/32	8/6	5/4	18/24	50/45	80/92	32	69/75
40	14/35	60/52	9	3	10	36	82/72	102/90	62	55	6,6/9	42,5/36	8	5/4	20/28	60/52	85/101	42/36	72/80
50	18/40	68/65	9	4	12	45	90	110	65	57	9	47/45	8/10	6/5	24/32	68/64	93/109	50/45	77/85
63	18/45	87/75	9	7/4	15/12	50	110/100	130/120	73/70	65/63	9	59,5/50	12	6/5	27/32	84/74	104/114	62/50	85/93

Male rear hinge in die-cast aluminium, ISO MP4 without pin

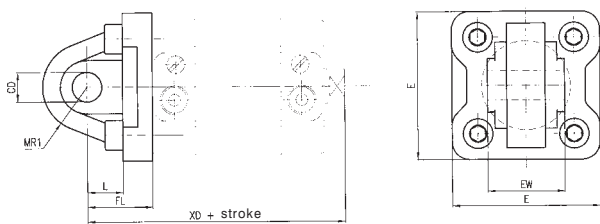

Cyl. Ø	Ø CD H7	E ±0,5	EW h14 ±0,2	FL ±0,2	L	MR1	XD	Part num. / Mass for...	
								Unitop RU-P/7/Kg	ISO 21287/Kg
16	6	27	12	16	10	6	58	RPF-11016/0,017	
20	8	34	16	20	14	8	63	RPF-11020/0,021	
25	8	38	16	20	14	8	65	RPF-11025/0,027	
32	10	48	26	22	12	15	73	RPF-11032/0,080	
40	12	54	28	25	15	18	77	-	KF-11040/0,100
50	12	65	32	27	15	20	80	-	KF-11050/0,170
63	16	75	40	32	20	23	89	-	KF-11063/0,250

• It is possible to use the male hinge together with the female hinge MF-21+Ø of microcylinders ISO 6432.

Male articulated hinge in die-cast aluminium Ø 32 ÷ 63 mm for compact cylinder according to ISO standard

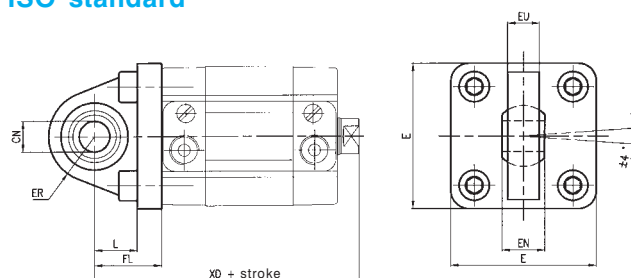

Cyl. Ø	CN H9	E	EN	ER	EU	FL	L	XD	Part num. / Mass for...	
									Unitop RU-P/7/Kg	ISO 21287/Kg
32	10	48	14	15	10,5	22	14	73	KF-11032S/0,10	
40	12	54	16	18	12	25	16,5	77	KF-10040S/0,20	
50	12	65	16	20	12	27	17,5	80	KF-10050S/0,30	
63	16	75	21	21	15	32	21,5	90	KF-10063S/0,35	

Technical modifications keep in reserve !

(2009/09)

Female rear hinge in die-cast aluminium with pin in zinc-plated steel

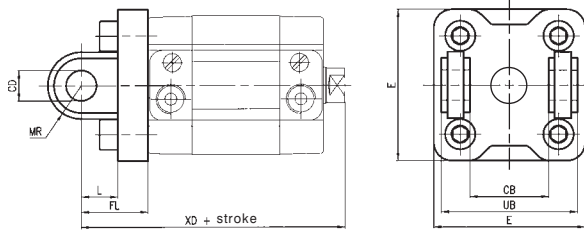

Hinge with pin

Part num. / Mass for...

Cyl. Ø	CB H14	C H9	E	FL ±0,2	L	MR	UB h14	XD	Unitop RU-P/7/Kg
32	26	10	48	22	12	11	45	73	KF-10032A/0,060
40	28	12	58	25	16	12,5	52	77	RPF-10040/0,104
50	32	12	66	27	16	12,5	60	80	RPF-10050/0,142
63	40	16	83	32	21	15	70	90	RPF-10063/0,240

Hinge with pin

Part num. / Mass for...

Cyl. Ø	CB H14	C H9	E	FL ±0,2	L	MR	UB h14	XD	ISO 21287/Kg
32	26	10	48	22	12	11	45	73	KF-10032A/0,10
40	28	12	58	25	15	13	52	77	KF-10040A/0,20
50	32	12	66	27	15	13	60	80	KF-10050A/0,30
63	40	16	83	32	20	17	70	90	KF-10063A/0,35

- Removing the pin it is possible to use the female hinge also in front.

Counter-hinge 90° in die-cast aluminium

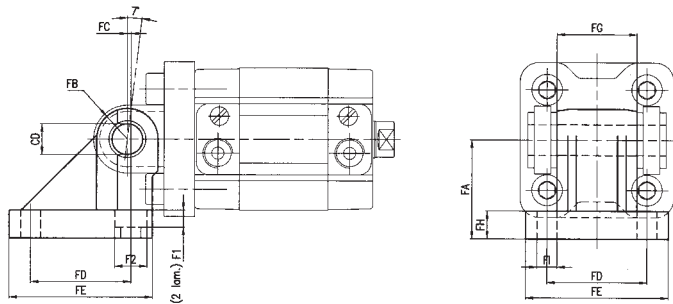

Cyl. Ø	Ø CD H9	FA Js15	FB	FC	FD	FE	FG -0.2/-0.6	FH	FI	F1	F2
32	10	32	10	1,2	32,5	46,5	26	9	6,4	5,5	10,5
40	12	36	12	2,6	38	51,5	28	9	6,4	5,5	10,5
50	12	45	12	0,3	46,5	63,5	32	9	8,4	5	13,5
63	16	50	16	3,3	56,5	73,5	40	10,5	8,4	5	13,5

Cyl. Ø	Part num.	Mass Kg
32	KF-19032	0,09
40	KF-19040	0,12
50	KF-19050	0,20
63	KF-19063	0,32

Intermediate hinge with fixing grub screw

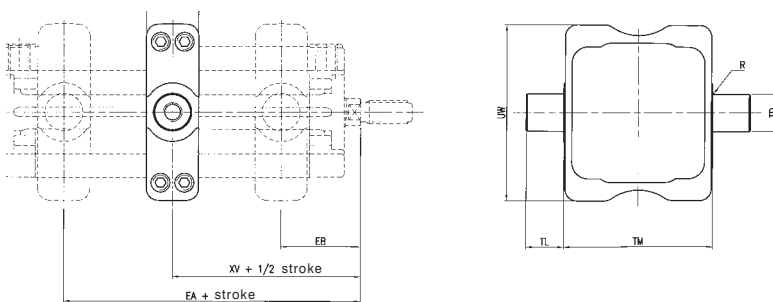

Cyl. Ø	EA (max)	EB (min)	I1 (max)	R (max)	TD (e9)	TL (h14)	TM (h14)	UW (max)	XV	
									Nom.	Toll.
32	24	34	22	0,5	12	12	50	65	29	±2
40	25	34	22	0,5	16	16	63	75	29,5	±2
50	26	35	22	1	16	16	75	95	30,5	±2
63	27	38	28	1	20	20	90	105	32,5	±2

Cyl. Ø	Part num.	Mass Kg
32	KDF-14032	0,13
40	RPF-14040	0,24
50	RPF-14050	0,32
63	RPF-14063	0,47

Min. cylinder stroke: 10 mm

V+1/2 stroke: hinge in the middle of the end-caps

Adaptor ring for rear centering ISO (upon request)

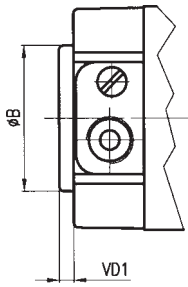

Cyl. Ø	Adaptor ring		Part number
	ØB	VD1	
32	30	3	RSF-09032
40	35	3	RSF-09040
50	40	3	RSF-09050
63	45	3	RSF-09063

Flange for female piston rod in zamac (Ø 16 ÷ 25 mm); in die-cast aluminium (Ø 32 ÷ 63 mm) (complete with fixing screw, standard supplied with octagonal cylinder types RO-RN series). If mounted on cylinder types RP-RM dimensions are the same as those of RO-RN series.

Flange for piston-rod with antirotation device in zamac (Ø 16 ÷ 25 mm); in die-cast aluminium (Ø 32 ÷ 63 mm) for RP 210... - RP 211... series (with fixing screws)



Cyl. Ø	Part number	Mass kg
16	RPF-28016	0,007
20	RPF-28020	0,018
25	RPF-28025	0,020
32	RPF-28032	0,024
40	RPF-28040	0,035
50	RPF-28050	0,057
63	RPF-28063	0,094

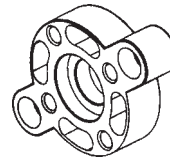

Cyl. Ø	Part number	Mass kg
16	RPF-29016	0,010
20	RPF-29020	0,018
25	RPF-29025	0,025
32	RPF-29032	0,026
40	RPF-29040	0,036
50	RPF-29050	0,065
63	RPF-29063	0,100

Piston rod nut in zinc-plated steel

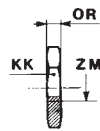
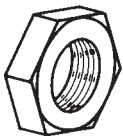

Cyl. Ø	ZM	KK	OR	Part number
16	M6 x 1	10	4	MF-16012
20-25	M8 x 1,25	13	5	MF-16020
32-40	M10 x 1,25	17	6	KF-16032
50-63	M12 x 1,25	19	7	KF-16040

Pin in zinc-plated steel with 2 circlips

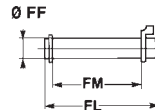

Cyl. Ø	FF	FL	FM	Mass kg	Part number
32	10	53	46	0,03	KF-18032
40	12	61,3	53	0,05	KF-18040
50	12	69	61	0,05	KF-18050
63	16	80,5	71	0,12	KF-18063

Fixing screws accessories

Cylindrical screw UNI 5931

(packing 100 pcs.)

Part n° AZ4-VN... suitable for mounting elements RPF-12... and RPF-13... series

Cyl. Ø	Screw	Part number
16	M4 x 18	AZ4-VN0418
20-25	M5 x 18	AZ4-VN0518
32-40	M6 x 20	AZ4-VN0620
50-63	M8 x 25	AZ4-VN0825

Cylindrical screw UNI 5931

Part n° AZ4-VN... suitable for mounting elements KF-10032/RPF-10... series

Cyl. Ø	Screw	Part num.
32-40	M6 x 25	AZ4-VN0625
50-63	M8 x 30	AZ4-VN0830

Female fork with clips in zinc-plated steel for piston rod according to ISO 8140 standard with pin

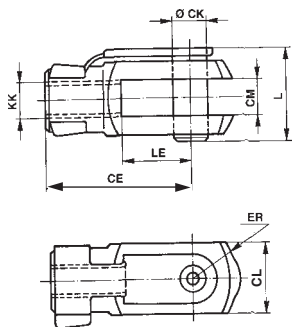

Cyl. Ø	CE	CK	CL	CM B12	ER	KK	L	LE	Masse kg	Part number
16	24	6	12	6	7	M6 x 1	16	12	0,019	MF-15016
20÷25	32	8	16	8	10	M8 x 1,25	22	16	0,046	MF-15020
32-40	40	10	20	10	16	M10 x 1,25	26	20	0,090	KF-15032
50-63	48	12	24	12	19	M12 x 1,25	32	24	0,15	KF-15040

Self-lubricating articulated fork in zinc-plated steel

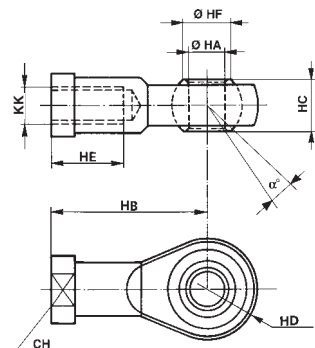

Cyl. Ø	a	CH	KK	HA	HB	HC	HD	HE	HF	Masse kg	Part number
16	13°	11	M6 x 1	6	30	9	10	12	9	0,026	MF-17012
20÷25	13°	14	M8 x 1,25	8	36	12	12	16	10,4	0,046	MF-17020
32-40	13°	17	M10 x 1,25	10	43	14	14	20	12,9	0,076	KF-17032
50-63	13°	19	M12 x 1,25	12	50	16	16	22	15,4	0,110	KF-17040

Fork with axially mounted articulated pin

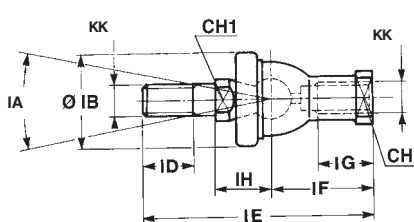

Cyl. Ø	CH	CH1	IA	KK	IH	IB	ID	IE	IF	IG	Masse kg	Part number
16	11	8	30°	M6 x 1	12,2	22	11	55,2	28	15	0,04	MF-22016
20÷25	14	10	30°	M8 x 1,25	16	28	12	65	32	16	0,075	MF-22020
32-40	17	11	30°	M10 x 1,25	19,5	32	15	74,5	35	18	0,120	KF-22025
50-63	19	11	30°	M12 x 1,25	22	36	17	84	40	20	0,185	KF-22040

Fork with angle-mounted articulated pin

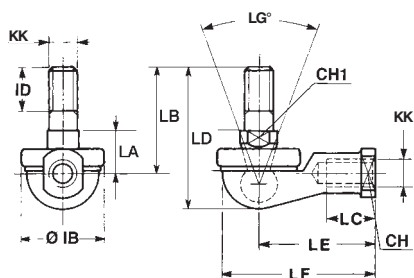

Cyl. Ø	CH	CH1	LG	KK	IB	ID	LA	LB	LC	LD	LE	LF	Masse kg	Part number
16	11	8	50°	M6 x 1	22	11	11	26	14	35,5	30	40	0,037	MF-23012
20÷25	14	10	50°	M8 x 1,25	28	12	14	31	17	42,5	36	48	0,067	MF-23020
32-40	17	11	50°	M10 x 1,25	32	15	17	37	21	50,5	43	57	0,110	KF-23025
50-63	19	17	50°	M12 x 1,25	36	17	19	42	27	57,5	50	66	0,165	KF-23040

Technical modifications keep in reserve !

(2009/09)