

2. COMPACT CYLINDERS series STRONG (RS, RQ)

A new series of compact cylinders for long strokes and heavy-duty applications standard supplied with oversized guides and rods, **the first one with adjustable pneumatic cushioning without variations in size**. The inter-axes, centering diameters and rods are in accordance with ISO 6431 and VDMA 24562 specifications.

Working pressure: 1,5 ÷ 10 bar
 Ambient temperature: -20°C ÷ 80°C
 Fluid: filtered air, lubricated or not
 Barrel profile of extruded aluminium alloy with chromium-plated piston rod.
 Oversized guides.
 Adjustable cushioning (10 mm ~).
 The version with non-rotating piston rod (RQ-...series) is standard supplied with assembled flange on the female rod.
 Max. operating speed: 1 m/s.
 Magnetic version.

Upon request

- Magnetic sensor DF-... (see page 2.27)
- Wire protection strap for magnetic sensor, part no.DHF-002100.
- Flange for RS series types 200-201-260-270.
- Hollow piston rod only for through piston rod version.
- Suitable for locking unit only with chromium-plated rod. (see page 2.28)

Codification Key

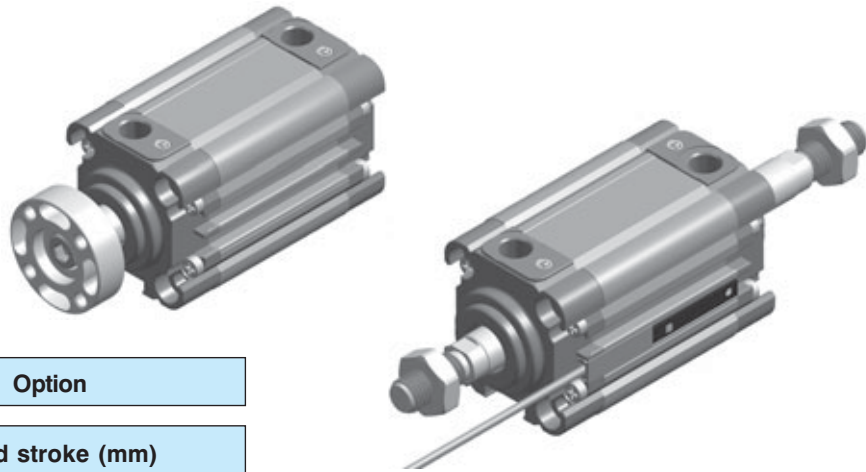
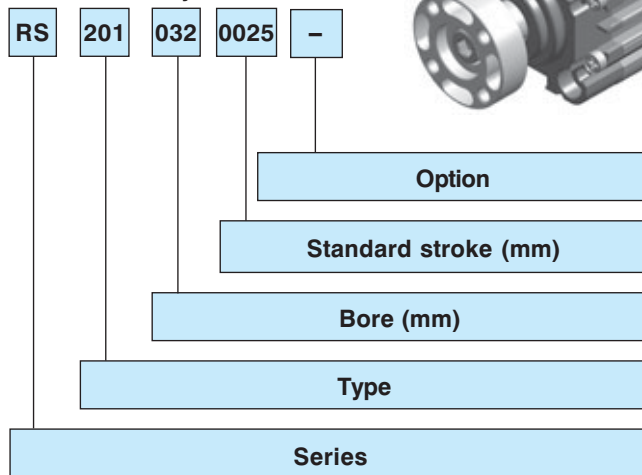

RQ series

- 1.. with piston rod in stainless steel
- 2.. with piston rod in chromium-plated steel
- 00 D.A.
- 01 D.A. through piston rod
- 20 D.A. long piston

SERIES

Compact cylinders STRONG Ø 032 ÷ 063 mm, magnetic version, with cushioning and oversized guides standard supplied:

Round barrel:

RS series - compact STRONG

Octagonal barrel

RQ series - compact STRONG non-rotating piston rod with flange.

TYPE

RS series

- 1.. with stainless steel piston rod
- 2.. with chromium-plated steel piston rod
- 00 D.A.
- 01 D.A. through piston rod
- 10 D.A. non-rotating piston rod
- 11 D.A. non-rotating through piston rod
- 20 D.A. long piston
- 60 S.A. retracted piston rod
- 70 S.A. extended piston rod
- 3.. with male piston rod in stainless steel
- 4.. with male piston rod in chromium-plated steel
- 00 D.A.
- 01 D.A. through piston rod
- 20 D.A. long piston
- 60 S.A. retracted piston rod
- 70 S.A. extended piston rod

BORE

032 - 040 - 050 - 063 mm

STANDARD STROKE

Single acting

0005-0010-0015-0020-0025 mm

Double acting

0005-0010-0015-0020-0025-0030-0040-0050-0060-0080 mm

Max stroke with guided piston rod (upon request):

Ø 32-40	0400 mm
Ø 50	0500 mm
Ø 63	0800 mm

Version with extended piston (upon request):

Ø 32-40	0800 mm
Ø 50-63	1000 mm

OPTION

- C** = with flange for RS series versions 100/101/160/170 and 200/201/260/270
- H** = hollow piston rod only for versions with through piston rod
- G** = prearranged for locking unit with the exception of single-acting cylinders and only with piston rod in chromium-plated steel.

Construction details

- Barrel in extruded aluminium alloy, externally and internally anodized 15 μm , plain profile, flush-mounted sensors.
- Die-cast end-caps in aluminium alloy.
- Self-tapping screws in zinc-plated steel.
- Chromium-plated steel rod; stainless steel upon request.
- Aluminium piston.
- Acetal resin slide.
- Oversized bearings.
- Piston seals in nitrile rubber.
- Polyurethane rod seals.
- Adjustable pneumatic cushioning for efficient deceleration of the piston and reduced sound pollution.

- D.A. piston in aluminium

- D.A. extended piston for supporting higher radial load



- Locking unit L1-N... series with chromium-plated piston rod except for versions with non-rotating device (RS-210...-RS-211...).

Nominal tolerance on stroke

Cyl. \varnothing	Tolerance mm
32 \div 50	+ 2/0
63	+ 2,5/0

Theoretical forces [N] developed at the working pressure [bar]

Cyl. \varnothing	Working area [mm ²]	Working pressure [bar]					
		2	4	6	8	10	
32	Thrust	804	161	322	482	643	804
	traction	691	138	276	414	553	691
40	Thrust	1256	251	502	754	1005	1256
	traction	1056	211	422	633	844	1055
50	Thrust	1962	393	785	1178	1570	1963
	traction	1649	330	660	990	1320	1650
63	Thrust	3116	623	1246	1869	2493	3116
	traction	2802	560	1120	1680	2240	2800

Maximum applicable torque [Nm] for RQ series non-rotating rod

Cyl. \varnothing	Torque [Nm]
32	2
40	3
50	5
63	8

In the case of pneumatic cylinders with a through rod, the theoretical force to be considered, in both directions, is always equal to the "traction" value indicated in the table. For practical purposes these values should be reduced taking into account the weight and sliding friction of the mobile equipment (~ -10%).

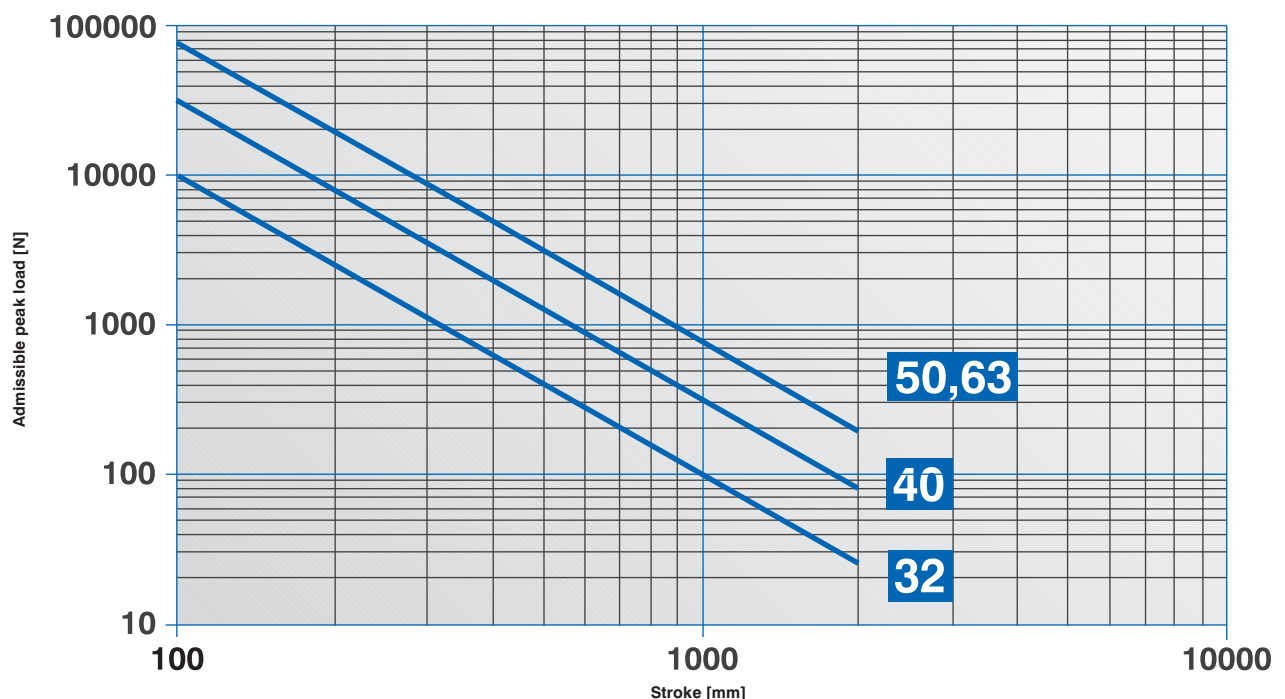

Double-acting cylinder RS 200... / RS 220...* series extended piston

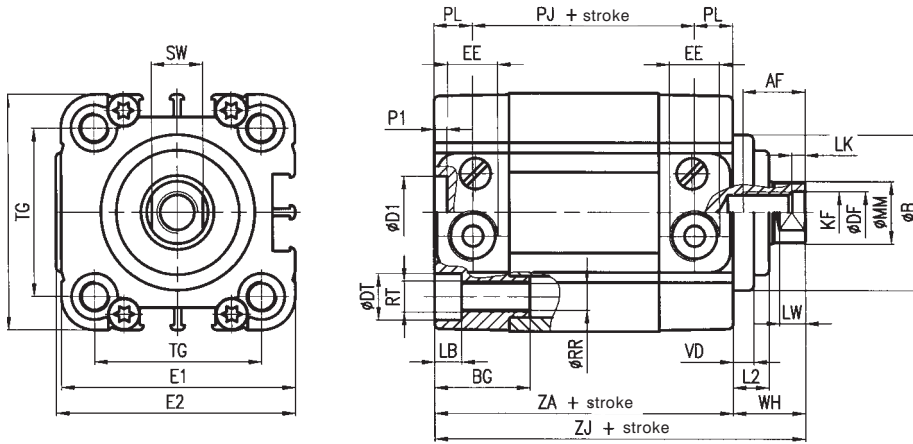
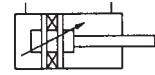

Mass RS 200...

Cyl. Ø	Cylinder stroke "0" (g)	Increase by mm stroke (g)	Moving part stroke "0" (g)	Increase by mm stroke (g)
32	215	2,65	70	0,9
40	347	4	110	1,6
50	520	5,6	180	2,5
63	800	6,55	260	2,5

Mass RS 220...

Cyl. Ø	Cylinder stroke "0" (g)	Increase by mm stroke (g)	Moving part stroke "0" (g)	Increase by mm stroke (g)
32	301,5	2,65	121,5	0,9
40	482	4	197	1,6
50	769	5,6	327	2,5
63	1151,5	6,55	485	2,5

Double-acting cylinder with male rod RS 400... / RS 420...* series extended piston

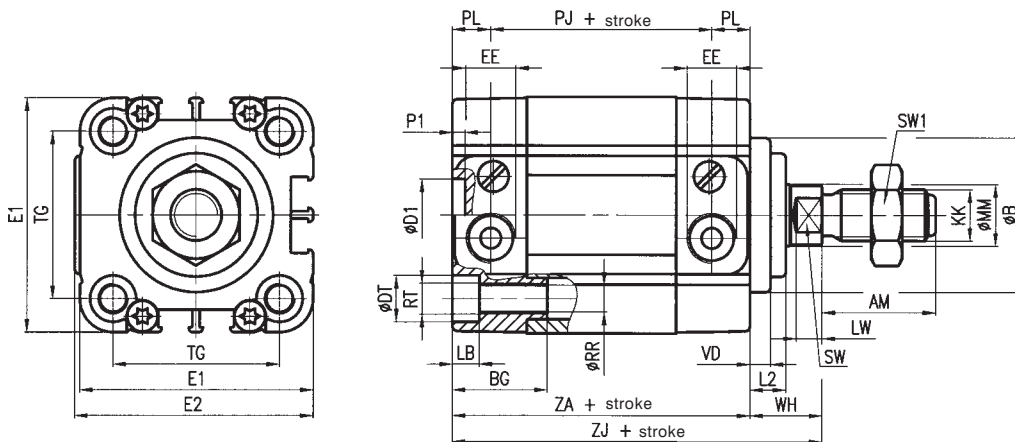

Mass RS 400...

Cyl. Ø	Cylinder stroke "0" (g)	Increase by mm stroke (g)	Moving part stroke "0" (g)	Increase by mm stroke (g)
32	245	2,65	100	0,9
40	392	4	155	1,6
50	600	5,6	260	2,5
63	880	6,55	340	2,5

Mass RS 420...

Cyl. Ø	Cylinder stroke "0" (g)	Increase by mm stroke (g)	Moving part stroke "0" (g)	Increase by mm stroke (g)
32	331,5	2,65	151,5	0,9
40	527	4	242	1,6
50	849	5,6	407	2,5
63	1231,5	6,55	565	2,5

Cyl. Ø	AF	AM	Ø B	BG	ØD1 H11	Ø DF	Ø DT	E1	E2	EE	KF	KK	L2	LB	LK	LW	Ø MM	P1	PJ	PL	Ø RR	RT	SW	SW1	TG	VD	WH	ZA	ZJ
32	12	22	30	18	14	8,2	9	46	47	G1/8	M8	M10x1,25	7	5,3	2	5	12	25	29	7,5	5,2	M6	10	17	32,5	4	14	44	58
40	16	24	35	18	14	10,2	9	56	57	G1/8	M10	M12x1,25	7	5,3	2	5	16	25	30	7,5	5,2	M6	13	19	38	4	14	45	59
50	20	32	40	24	18	12,2	11	66	67	G1/8	M12	M16x1,5	10	6,5	2	6	20	25	30	7,5	6,5	M8	17	24	46,5	5	18	45	63
63	20	32	45	24	18	12,2	11	79	80	G1/8	M12	M16x1,5	10	6,5	2	6	20	25	34	7,5	6,5	M8	17	24	56,5	5	18	49	67

* For cylinder types with extended piston, dimensions PJ, ZA and ZJ will be increased by 20 mm (Ø 32-40 mm) and 25 mm (Ø 50-63 mm).

Technical modifications keep in reserve !

(2009/09)

Double-acting cylinder, through piston rod RS 201 ... series

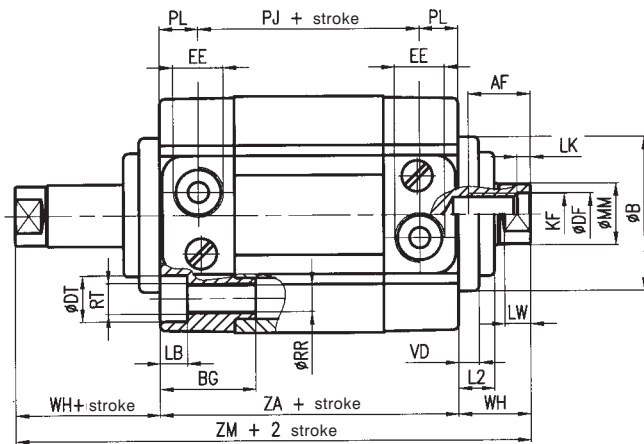
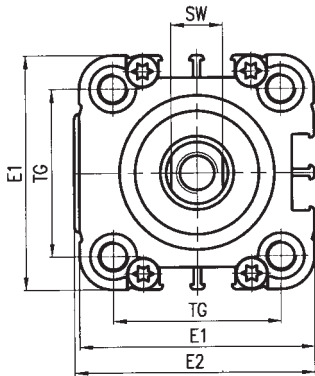
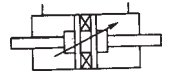

For version with hollow through piston rod, option H in codification key:

Cyl. Ø	Hole mm
32-40	4,5
50-63	6

Mass

Cyl. Ø	Cylinder stroke "0" (g)	Increase by mm stroke (g)	Moving part stroke "0" (g)	Increase by mm stroke (g)
32	245	3,55	96	1,8
40	392	5,6	151	3,2
50	596	8,1	250	5
63	875	9,05	330	5

Double-acting cylinder, through male piston rod RS 401 ... series

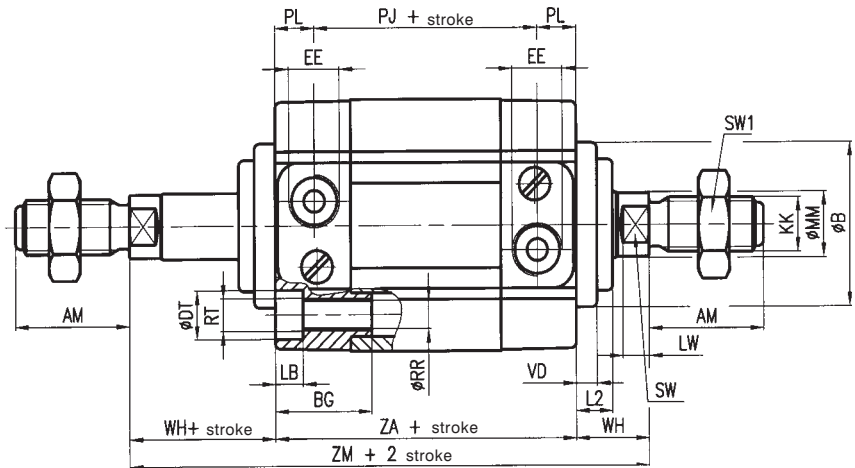
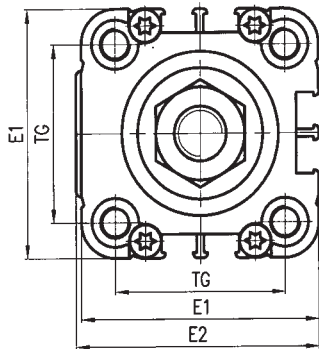

Mass

Cyl. Ø	Cylinder stroke "0" (g)	Increase by mm stroke (g)	Moving part stroke "0" (g)	Increase by mm stroke (g)
32	305	3,55	156	1,8
40	482	5,6	241	3,2
50	756	8,1	410	5
63	1035	9,05	490	5

Cyl. Ø	AF	AM	Ø B	BG	Ø DF	Ø DT	E1	E2	EE	KF	KK	L2	LB	LK	LW	Ø MM	PJ	PL	Ø RR	RT	SW	SW1	TG	VD	WH	ZA	ZM
32	12	22	30	18	8,2	9	46	47	G1/8	M8	M10x1,25	7	5,3	2	5	12	29	7,5	5,2	M6	10	17	32,5	4	14	44	72
40	16	24	35	18	10,2	9	56	57	G1/8	M10	M12x1,25	7	5,3	2	5	16	30	7,5	5,2	M6	13	19	38	4	14	45	73
50	20	32	40	24	12,2	11	66	67	G1/8	M12	M16x1,5	10	6,5	2	6	20	30	7,5	6,5	M8	17	24	46,5	5	18	45	81
63	20	32	45	24	12,2	11	79	80	G1/8	M12	M16x1,5	10	6,5	2	6	20	35	7,5	6,5	M8	17	24	56,5	5	18	50	86

Double-acting cylinder with non-rotating device RS 210 ... series

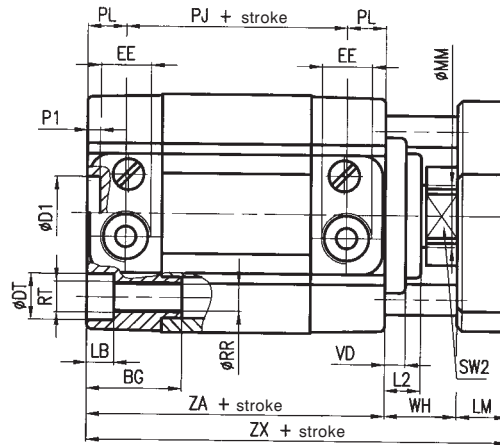
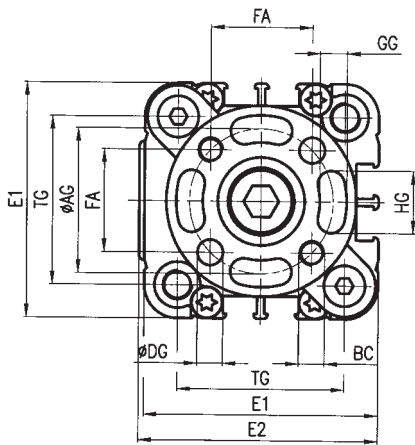
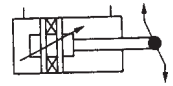

Mass

Cyl. Ø	Cylinder stroke "0" (g)	Increase by mm stroke (g)	Moving part stroke "0" (g)	Increase by mm stroke (g)
32	255	3,09	110	1,34
40	414	4,8	177	2,4
50	622	6,4	282	3,3
63	952	7,79	412	3,7

Double-acting cylinder, through piston rod with non-rotating device RS 211 ... series

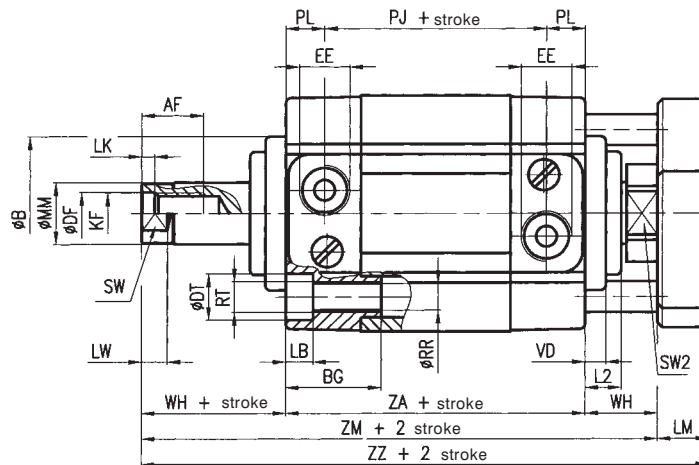
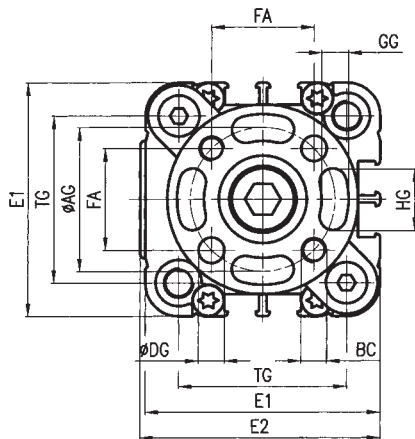
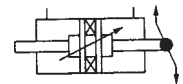

Mass

Cyl. Ø	Cylinder stroke "0" (g)	Increase by mm stroke (g)	Moving part stroke "0" (g)	Increase by mm stroke (g)
32	285	3,99	136	2,24
40	459	6,4	218	4
50	698	8,9	352	5,8
63	1025	10,29	482	6,24

Cyl. Ø	AF	ø AG	ø B	BC	BG	øD1 H11	ø DF	ø DG	ø DT
32	12	28	30	M5	18	14	8,2	5	9
40	16	33	35	M5	18	14	10,2	5	9
50	20	42	40	M6	24	18	12,2	6	11
63	20	50	45	M6	24	18	12,2	6	11

Cyl. Ø	E1	E2	EE	FA	GG	HG	KF	L2	LB	LM	LK	LW	ø MM	P1	PJ	PL	ø RR	RT	SW	SW2	TG	VD	WH	ZA	ZM	ZX	ZZ
32	46	47	G1/8	19,8	5,2	11	M8	7	5,3	10	2	5	12	2,5	29	7,5	5,2	M6	10	17	32,5	4	14	44	72	68	82
40	56	57	G1/8	23,3	5,2	15	M10	7	5,3	10	2	5	16	2,5	30	7,5	5,2	M6	13	19	38	4	14	45	73	69	83
50	66	67	G1/8	29,7	6,2	19	M12	10	6,5	12	2	6	20	2,5	30	7,5	6,6	M8	17	24	46,5	5	18	45	81	75	93
63	79	80	G1/8	35,4	6,2	25	M12	10	6,5	12	2	6	20	2,5	35	7,5	6,6	M8	17	24	56,5	5	18	50	86	80	98

Technical modifications keep in reserve !

(2009/09)

Double-acting cylinder with non-rotating rod RQ 200... / RQ 220...* series extended piston

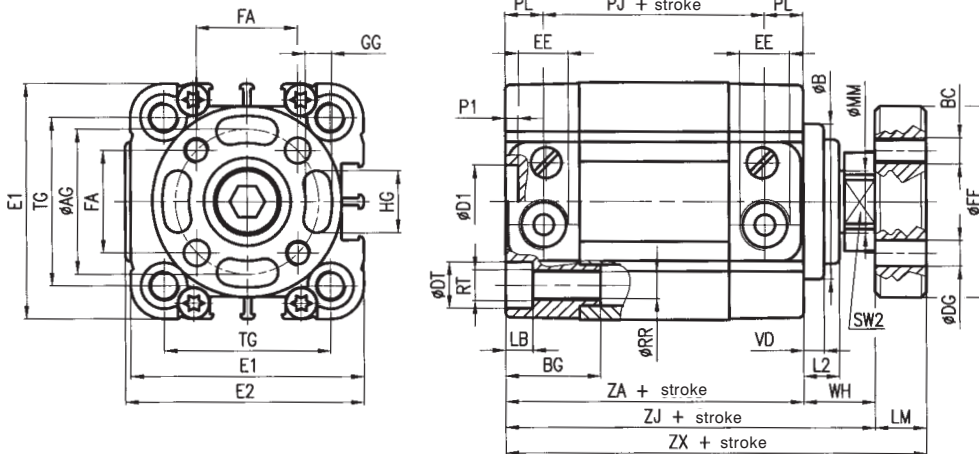
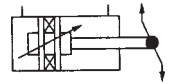

If it is necessary to remove the flange from the rod, oppose the force needed to unscrew it by using exclusively the hexagon wrench SW2.

Mass RQ 200...

Cyl. Ø	Cylinder stroke "0" (g)	Increase by mm stroke (g)	Moving part stroke "0" (g)	Increase by mm stroke (g)
32	240	2,65	94	0,9
40	386	4	148,5	1,6
50	587	5,6	247	2,5
63	894	6,55	354	2,5

Mass RQ 220...

Cyl. Ø	Cylinder stroke "0" (g)	Increase by mm stroke (g)	Moving part stroke "0" (g)	Increase by mm stroke (g)
32	326,5	2,65	146,5	0,9
40	522	4	237	1,6
50	839	5,6	397	2,5
63	1249,5	6,55	583	2,5

Double-acting cylinder non rotating through rod RQ 201... series

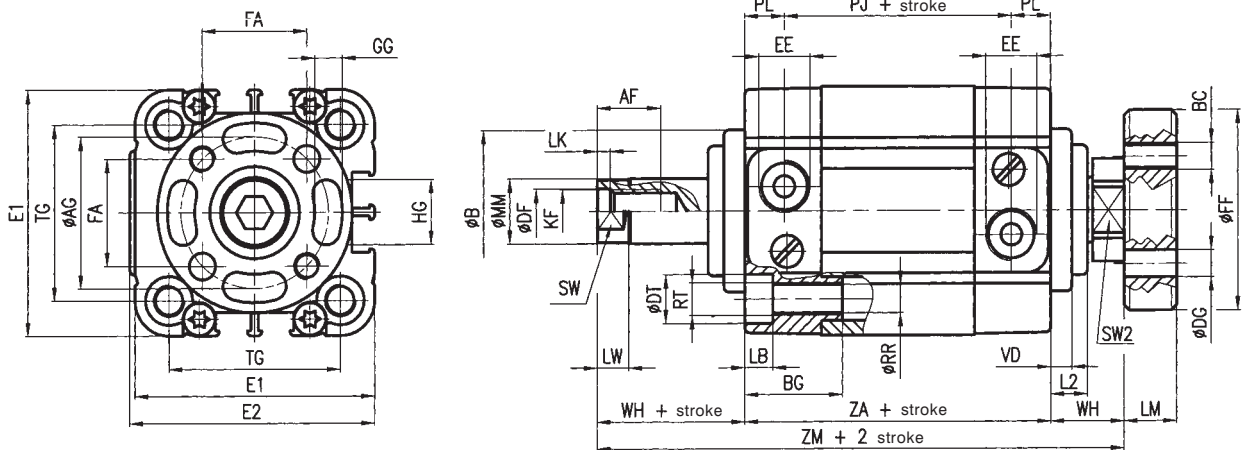
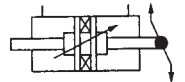

Mass

Cyl. Ø	AF	Ø AG	Ø B	BC	BG	ØD1 H11	Ø DF	Ø DG	Ø DT	E1	E2	EE	FA	Ø FF
32	12	28	30	M5	18	14	8,2	5	9	46	47	G1/8	19,8	37
40	16	33	35	M5	18	14	10,2	5	9	56	57	G1/8	23,3	42
50	20	42	40	M6	24	18	12,2	6	11	66	67	G1/8	29,7	52
63	20	50	45	M6	24	18	12,2	6	11	79	80	G1/8	35,4	64

Cyl. Ø	Cylinder stroke "0" (g)	Increase by mm stroke (g)	Moving part stroke "0" (g)	Increase by mm stroke (g)
32	270	3,55	120	1,8
40	431	5,6	189,5	3,2
50	663	8,1	317	5
63	969	9,05	424	5

Cyl. Ø	GG	HG	KF	L2	LB	LM	LK	LW	Ø MM	P1	PJ	PL	Ø RR	RT	SW	SW2	TG	VD	VD 1	WH	ZA	ZM	ZJ	ZX
32	5,2	11	M8	7	5,3	10	2	5	12	2,5	29	7,5	5,2	M6	10	17	32,5	4	3	14	44	72	58	68
40	5,2	15	M10	7	5,3	10	2	5	16	2,5	30	7,5	5,2	M6	13	19	38	4	3	14	45	73	59	69
50	6,2	19	M12	10	6,5	12	2	6	20	2,5	30	7,5	6,6	M8	17	24	46,5	5	3	18	45	81	63	75
63	6,2	25	M12	10	6,5	12	2	6	20	2,5	34	7,5	6,6	M8	17	24	56,5	5	3	18	49	85	67	79

* For cylinder types with extended piston, dimensions PJ, ZA and ZJ, ZX will be increased by 20 mm (Ø 32-40 mm), and 25 mm (Ø 50-63 mm).

Front and rear flange in zinc-plated steel, ISO MF1-MF2

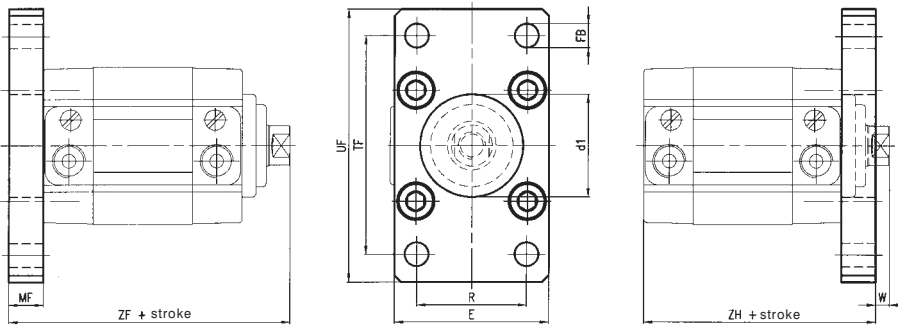

Cyl. Ø	Part number	Mass kg
32	KF-12032	0,20
40	KF-12040	0,25
50	KF-12050	0,50
63	KF-12063	0,65

Angle bracket in zinc-plated steel, ISO MS1

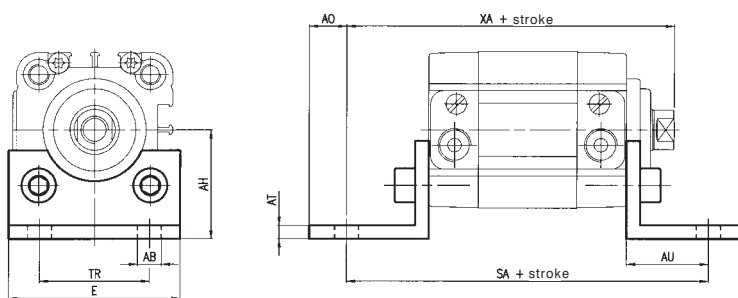

Cyl. Ø	Part number	Mass kg
32	KF-13032	0,07
40	KF-13040	0,09
50	KF-13050	0,20
63	KF-13063	0,20

Adaptor ring for rear centering ISO (upon request)

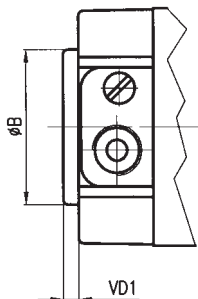

Cyl. Ø	Part number
32	RSF-09032
40	RSF-09040
50	RSF-09050
63	RSF-09063

Rear female hinge in die-cast aluminium with pin in zinc-plated steel ISO MP2

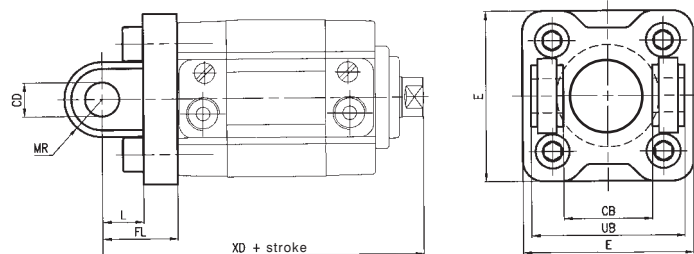

Cyl. Ø	Part number	Mass kg
32	KF-10032A	0,06
40	KF-10040A	0,08
50	KF-10050A	0,15
63	KF-10063A	0,25

By removing the pin it is possible to use the female hinge also in front.

Flange											Bracket						Adaptor ring		Female hinge with pin										
Cyl. Ø	Ød1 H11	E	ØFB H13	W	MF	R Js14	TF Js14	UF	ZF	ZH	ØAB H13	AH Js15	AO	AT	AU ± 0.2	E	SA	TR	XA	ØB	VD1	CB H14	ØCD H9	E	FL	L	MR	UB h14	XD
32	30	45	7	4	10	32	64	80	68	54	7	32	6	4	24	45	92	32	82	30	3	26	10	48	22	12	11	45	80
40	35	52	9	4	10	36	72	90	69	55	9	36	8	4	28	52	101	36	87	35	3	28	12	54	25	15	13	52	84
50	40	65	9	6	12	45	90	110	75	57	9	45	10	5	32	64	109	45	95	40	3	32	12	65	27	15	13	60	90
63	45	75	9	6	12	50	100	120	79	61	9	50	12	5	32	74	113	50	99	45	3	40	16	75	32	20	17	70	99

Rear male hinge in die-cast aluminium ISO MP4 without pin

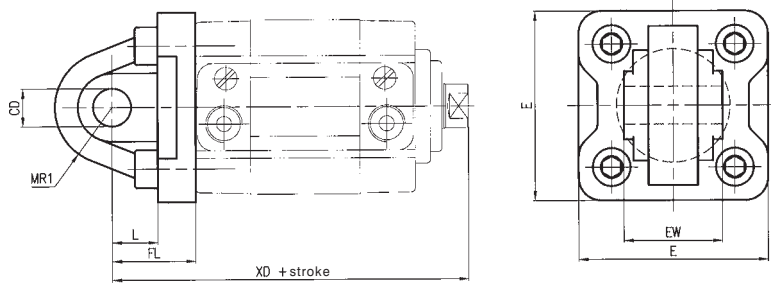

Cyl. Ø	Part number	Mass kg
32	KF-11032	0,20
40	KF-11040	0,25
50	KF-11050	0,50
63	KF-11063	0,65

Articulated male hinge in die-cast aluminium

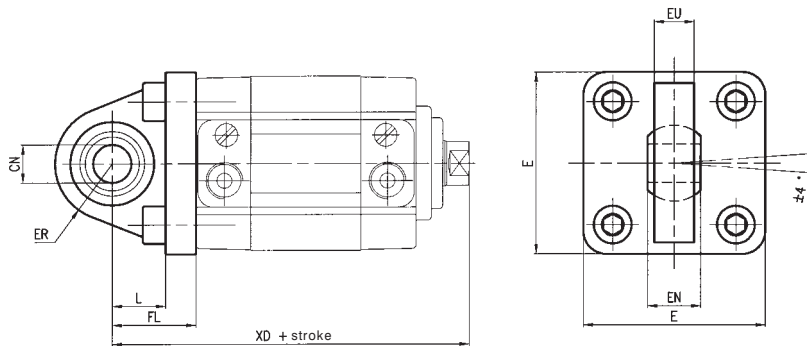

Cyl. Ø	Part number	Mass kg
32	KF-11032S	0,10
40	KF-11040S	0,20
50	KF-11040S	0,30
63	KF-11063S	0,35

Counter-hinge 90° in die-cast aluminium

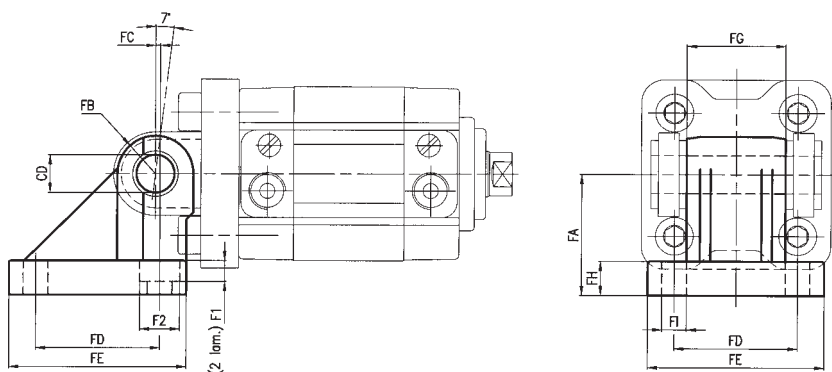

Cyl. Ø	Part number	Mass kg
32	KF-19032	0,09
40	KF-19040	0,12
50	KF-19050	0,20
63	KF-19063	0,32

Technical modifications keep in reserve !

(2009/09)

Rear male hinge								Articulated male hinge							Counter-hinge											
Cyl. Ø	ØCD H9	E	EW toll. -0.2/-0.6	FL	L	MR1	XD	ØCN H9	E	EN	ER	EU	FL	L	XD	ØCD H9	FA Js15	FB	FC	FD	FE	FG -0.2/-0.6	FH	FI	F1	F2
32	10	48	26	22	12	15	80	10	48	14	15	10.5	22	14	80	10	32	10	1.2	32.5	46.5	26	9	6.4	5.5	10.5
40	12	54	28	25	15	18	84	12	54	16	18	12	25	16.5	84	12	36	12	2.6	38	51.5	28	9	6.4	5.5	10.5
50	12	65	32	27	15	20	90	12	65	16	20	12	27	17.5	90	12	45	12	0.3	46.5	63.5	32	9	8.4	5	13.5
63	16	75	40	32	20	23	99	16	75	21	23	15	32	21.5	99	16	50	16	3.3	56.5	73.5	40	10.5	8.4	5	13.5

Intermediate hinge with grub screws

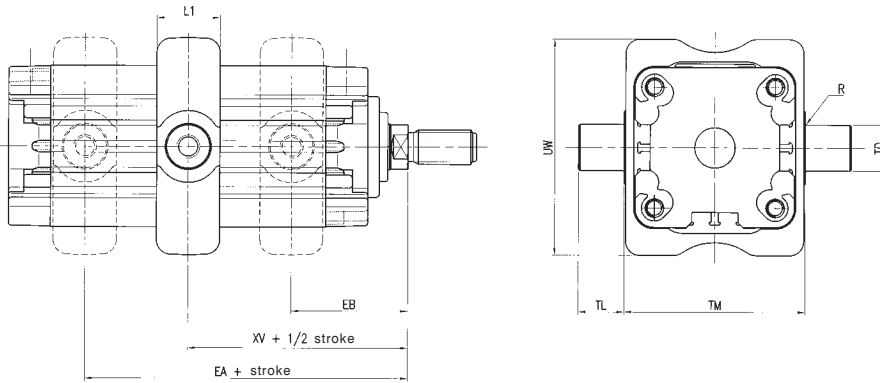

Cyl. Ø	EA (max)	EB (min)	l1 (max)	R (max)	TD (e9)	TL (h14)	TM (h14)	UW (max)	XV	
									Nom.	Tol.
32	31	41	22	0,5	12	12	50	65	36	±2
40	32	41	22	0,5	16	16	63	75	36,5	±2
50	36	45	22	1	16	16	75	95	40,5	±2
63	37	48	28	1	20	20	90	105	42,5	±2

Cyl. Ø	Part number	Mass kg
32	KDF-14032	0,13
40	KDF-14040	0,24
50	KDF-14050	0,32
63	KDF-14063	0,47

Flange for female rod in die-cast aluminium, (with fixing screw standard supplied with octagonal cylinders RQ series)



Cyl. Ø	Part number	Mass kg
32	RPF-28032	0,024
40	RSF-28040	0,035
50	RSF-28050	0,057
63	RSF-28063	0,094

Flange for rod with non-rotating device in die-cast aluminium for RS210.../RS211... series (fixing screws included)

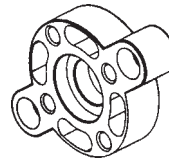

Cyl. Ø	Part number	Mass kg
32	RPF-29032	0,026
40	RSF-29040	0,036
50	RSF-29050	0,065
63	RSF-29063	0,100

Pin in zinc-plated steel with 2 circlips

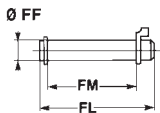

Cyl. Ø	FF f8	FL	FM	Mass kg	Part number
32	10	53	46	0,03	KF-18032
40	12	61,3	53	0,05	KF-18040
50	12	69	61	0,05	KF-18050
63	16	80,5	71	0,12	KF-18063

Rod nut in zinc-plated steel

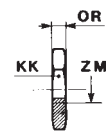

Cyl. Ø	ZM	KK	OR	Part number
32	M10x1,25	17	6	KF-16032
40	M12x1,25	19	7	KF-16040
50-63	M16x1,5	24	8	KF-16050

Fixing screws for accessories

Cylindrical screw UNI 5931

Part n° AZ4-VN... suitable for mounting elements KF-12... and KF-13... series

Cyl. Ø	Screw	Part number
32-40	M6 x 20	AZ4-VN0620
50-63	M8 x 25	AZ4-VN0825

Cylindrical screw UNI 5931

Part n° AZ4-VN... suitable for mounting elements KF-19... series (Ø 32-40)

Cyl. Ø	Screw 2 pcs. per type	Part number
32-40	M6 x 20	AZ4-VN0620
	M6 x 25	AZ4-VN0625

Cylindrical screw UNI 5931

Part n° AZ4-VN... suitable for mounting elements KF-10... KF-11... series

Cyl. Ø	Screw	Part number
32-40	M6 x 25	AZ4-VN0625
50-63	M8 x 30	AZ4-VN0830

Cylindrical screw UNI 5931

Part n° AZ4-VN... suitable for mounting elements KF-19... series (Ø 50-63)

Cyl. Ø	Screw 2 pcs. per type	Part number
50-63	M8 x 25	AZ4-VPA0825
	M8 x 30	AZ4-VPA0830

Female fork with clips in zinc-plated steel for piston rod according to ISO 8140 standard with pin

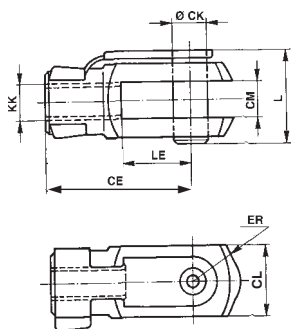

Cyl. Ø	CE	CK	CL	CM	ER	KK	L	LE	Mass kg	Part number
				B12						
32	40	10	20	10	16	M10 x 1,25	26	20	0,09	KF - 15032
40	48	12	24	12	19	M12 x 1,25	32	24	0,015	KF - 15040
50-63	64	16	32	16	25	M16 x 1,5	39	32	0,34	KF - 15050

Articulated self-lubricating fork in zinc-plated steel

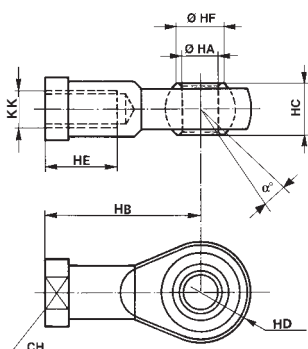

Cyl. Ø	a	CH	KK	HA	HB	HC	HD	HE	HF	Mass kg	Part number
				H7		0 -0,12					
32	13°	17	M10 x 1,25	10	43	14	14	20	12,9	0,076	KF - 17032
40	13°	19	M12 x 1,25	12	50	16	16	22	15,4	0,11	KF - 17040
50-63	15°	22	M16 x 1,5	16	64	21	21	28	19,3	0,22	KF - 17050

Fork with axially mounted articulated pin

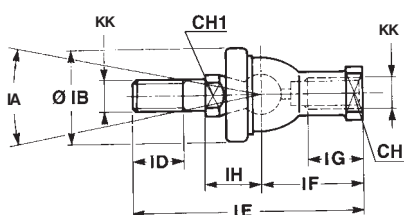

Cyl. Ø	CH	CH1	IA	KK	IH	IB	ID	IE	IF	IG	Mass kg	Part number
					±0,3							
32	17	11	30°	M10 x 1,25	19,5	32	15	74,5	35	18	0,12	KF - 22025
40	19	17	30°	M12 x 1,25	22	36	17	84	40	20	0,185	KF - 22040
50-63	22	19	22°	M16 x 1,5	27,5	47	23	112	50	27	0,36	KF - 22050

Fork with angle-mounted articulated pin

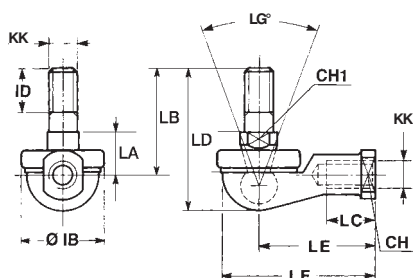

Cyl. Ø	CH	CH1	LG	KK	IB	ID	LA	LB	LC	LD	LE	LF	Mass kg	Part number
							±0,3							
32	17	11	50°	M10 x 1,25	32	15	17	37	21	50,5	43	57	0,11	KF - 23025
40	19	17	50°	M12 x 1,25	36	17	19	42	27	57,5	50	66	0,165	KF - 23040
50-63	22	19	40°	M16 x 1,5	47	23	23,5	60	33	79,5	64	84	0,33	KF - 23050

Technical modifications keep in reserve !

(2009/09)