

COMPACT CYLINDERS Ø20-100mm ECOMPACT(S) Series 1500

CYLINDERS ACCORDING TO STANDARD ISO 21287 ECOMPACT
(series 1500 chapter 4)

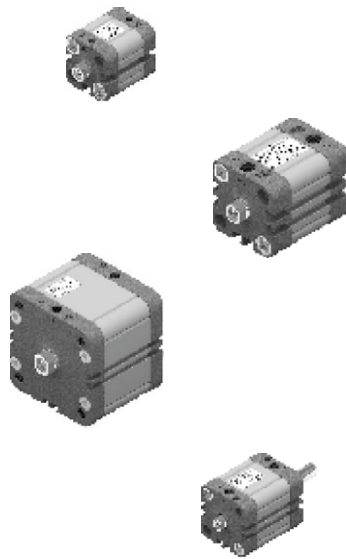

Basic and push/pull version



Ordering code

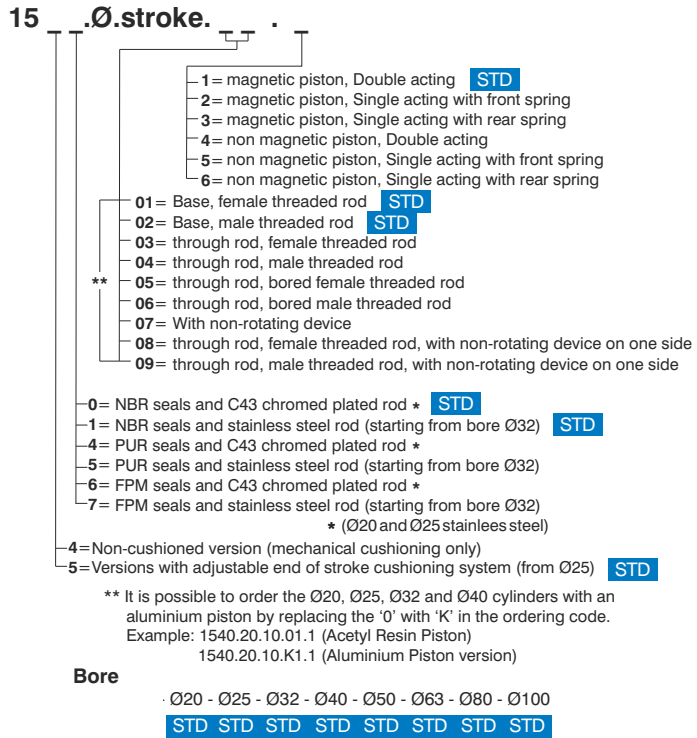

Standard strokes
DOUBLE ACTING BASIC Version & PUSH/PULL ROD (without cushioning device)
Ø20 and Ø25: from 5 to 200 mm
Ø32 and Ø40: from 5 to 300 mm
Ø50 and Ø63: from 5 to 400 mm
Ø80 and Ø100: from 5 to 500 mm
(with cushioning device)
Ø25: from 25 to 200 mm
Ø32 and Ø40: from 25 to 300 mm
Ø50 and Ø63: from 25 to 400 mm
Ø80 and Ø100: from 25 to 500 mm

DOUBLE ACTING BASIC Version PUSH/PULL ROD BORED (without cushioning device)
from Ø20 to Ø40: from 5 to 50 mm
Ø50 and Ø63: from 5 to 75 mm
Ø80 and Ø100: from 5 to 80 mm
(with cushioning device)
from Ø25 to Ø40: from 25 to 50 mm
Ø50 and Ø63: from 25 to 75 mm
Ø80 and Ø100: from 25 to 80 mm

DOUBLE ACTING Version WITH NON-ROTATING DEVICE (without cushioning device)
Ø20 and Ø25: from 5 to 40 mm
from Ø32 to Ø100: from 5 to 80 mm
(with cushioning device)
Ø25: from 25 to 40 mm
from Ø32 to Ø100: from 25 to 80 mm
Bore
Ø20 - Ø25 - Ø32 - Ø40 - Ø50 - Ø63 - Ø80 - Ø100

SINGLE ACTING Version
from Ø20 to Ø100: from 5 to 25 mm

Example code
1550.50.200.01.1

(Double Acting Ecompact cylinder Ø50mm stroke 200mm with Adjustable cushioning and Female thread rod with NBR seals and Magnetic piston)



General

These cylinders are built according to ISO 21287 standards. New barrel profile has two sensor slots on the three sides (Ø20 and Ø25 one slot) suitable for sensors 1580_ , MRS_ , MHS_ series housing, without need for adaptors.

Versions with end stroke adjustable pneumatic cushioning are also available, allowing adjustments to deceleration and keeping the required overall dimensions according to ISO 21287.

For fixing operation is possible to use the four threaded holes on the end covers, or screws in body holes, alternatively all the fixing devices of UNITOP RU-P/6-P/7 (Ø20 and Ø25) and ISO 15552 (from Ø32 to Ø100) series.

Construction characteristics

Body	anodised aluminium
End cap	aluminium alloy casting painted
Bearing piston rod	sintered bronze
Piston rod	from Ø20 to Ø25 stainless steel from Ø32 to Ø100 C43 chromed (on request stainless steel)
Piston	from Ø20 to Ø40 acetal resin (aluminium on request), Ø50 and Ø100 aluminium (with FPM seals, aluminium piston for all standard diameters)
Seals	Standard: NBR Oil resistant rubber, PUR Piston rod seals (PUR or FPM seals available upon request)
Spring	stainless steel
Fixing screws	plated zinc steel

Technical characteristics

Fluid	filtered and preferably lubricated air, or non-lubricated (if air is lubricated, the lubrication must be constant)
Max. pressure	10 bar
Operating temperature	-5°C - +70°C with standard seals (magnetic or non magnetic piston)
	-30°C - +80°C with PUR seals (magnetic or non magnetic piston)
	-5°C - +80°C with FPM seals (magnetic piston)
	-5°C - +150°C with FPM seals (non magnetic piston)

Please follow the suggestions below to ensure a long life for these cylinders:

- use clean and lubricated air
- correct alignment during assembly with regard to the applied load so as to avoid radial components or bending the rod.
- avoid high speeds together with long strokes and heavy loads: this would produce kinetic energy which the cylinder cannot absorb, especially if used as a limit stop (in this case use mechanical stop device and aluminium piston)
- evaluate the environmental characteristics of cylinder used (high temperature, hard atmosphere, dust, humidity etc.)

Please note: air must be dried for applications with lower temperature.

Use hydraulic oils H class (ISO Vg32) for correct continued lubrication.

Our Technical Department will be glad to help.

Stroke tolerance, minimum and maximum spring loads and cushioning length

Bore (mm)	Stroke tolerance (mm)	Minimum and maximum springs load (N)		Cushioning length (mm)
		min.	max.	
Ø20	+1.5 / 0 mm	10.8	19.6	/
Ø25		16.7	22.6	5
Ø32	+2 / 0 mm	19.6	25.5	6.5
Ø40		25.5	42.2	8
Ø50		44.1	96.3	7.5
Ø63	+2.5 / 0mm	44.1	96.3	7.5
Ø80		63.8	100.1	8
Ø100		107.9	193.3	12

Basic version male piston rod

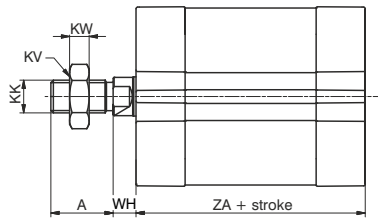

Push/pull version male rod

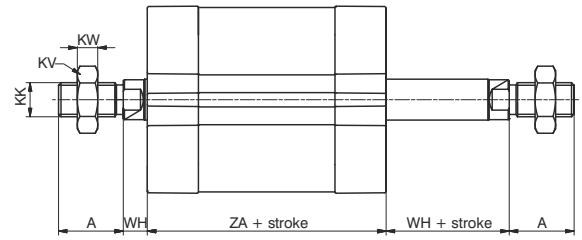

Push - pull version bored female piston rod

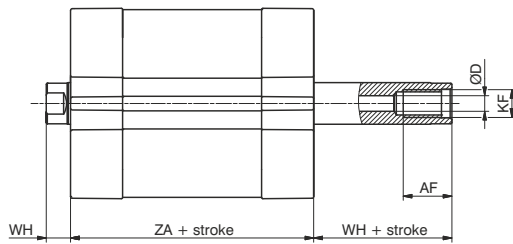

Push - pull version bored male piston rod

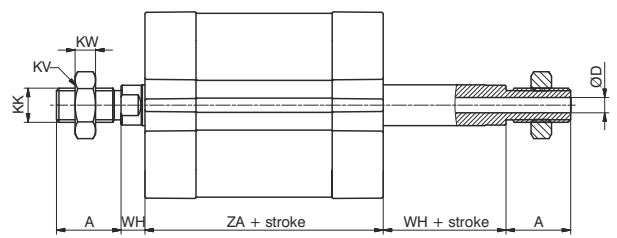

Non-rotating version

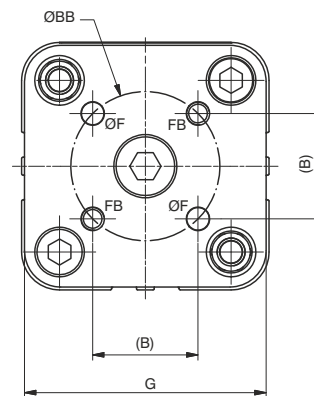
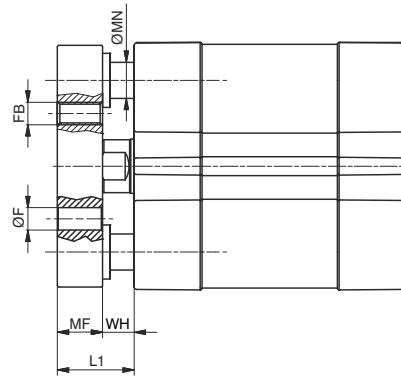

Bore	Ø20	Ø25	Ø32	Ø40	Ø50	Ø63	Ø80	Ø100
A (0/-0.5)	16	16	19	19	22	22	28	28
AF (min)	12	12	14	14	18	18	24	24
B	12	15.6	19.8	23.3	29.7	35.4	46	56.6
BB (±0.1)	Ø	17	22	28	33	42	65	80
D	Ø	3	3.8	4.5	4.5	6	6	8
F (+0.1/0)	Ø	4	5	5	5	6	6	8
FB	M4	M5	M5	M5	M6	M6	M8	M10
G	35	39.5	45	52	65	75	95	115
KF	M6	M6	M8	M8	M10	M10	M12	M12
KK	M8x1.25	M8x1.25	M10x1.25	M10x1.25	M12x1.25	M12x1.25	M16x1.5	M16x1.5
KV	13	13	17	17	19	19	24	24
KW	5	5	6	6	7	7	8	8
L1	14	14	17	17	20	20	24	24
MF (+0.1/0)	8	8	10	10	12	12	14	14
MN (f 7)	Ø	6	6	8	8	10	10	12
WH (±1)	6	6	7	7	8	8	10	10
ZA (±0.5)	37	39	44	45	45	49	54	67

Technical modifications keep in reserve !

(2020/07)

BASIC version
double and single acting



Ø20 and Ø25

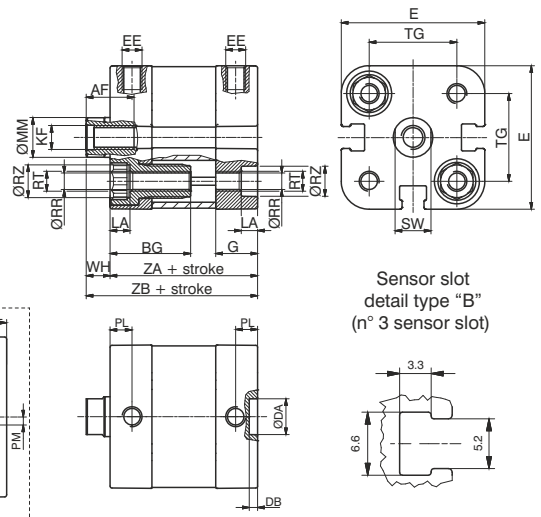
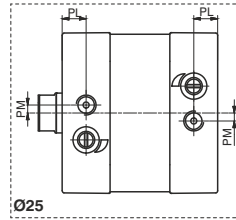

Sensor slot detail type "B" (n° 3 sensor slot)

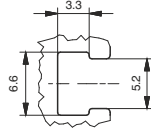

from Ø32 to Ø63

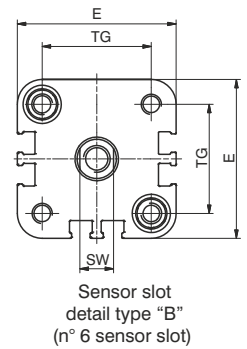
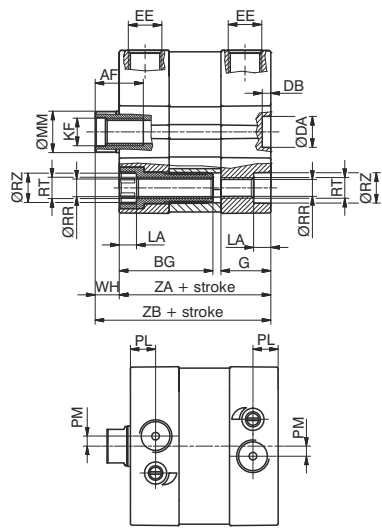

Sensor slot detail type "B" (n° 6 sensor slot)

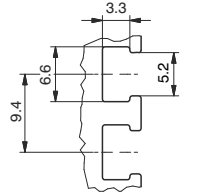

Ø80 and Ø100

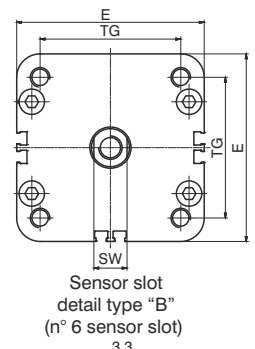
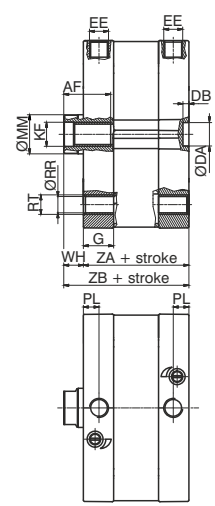

Sensor slot detail type "B" (n° 6 sensor slot)

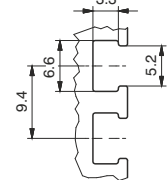

Technical modifications keep in reserve !

(2020/07)

**PUSH/PULL rod version
double and single acting**

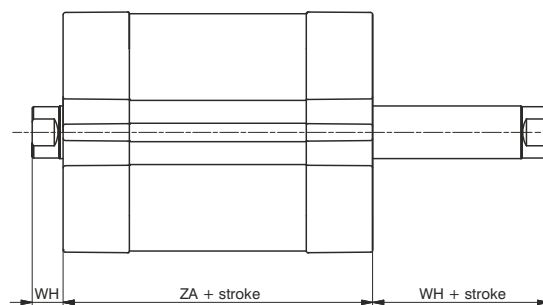

Table of dimensions

	Ø20	Ø25	Ø32	Ø40	Ø50	Ø63	Ø80	Ø100
Bore	Ø20	Ø25	Ø32	Ø40	Ø50	Ø63	Ø80	Ø100
AF (min)	12	12	14	14	18	18	24	24
BG	20	20	16	16	16	16	/	/
DA (H9) Ø	9	9	9	9	12	12	12	12
DB (+0.1/0)	2.1	2.1	2.5	2.5	2.6	2.6	3	3
E (max)	36	40.5	47.5	55	66	78	96	116
EE	M5	M5	G1/8	G1/8	G1/8	G1/8	G1/8	G1/8
G	10.5	12	14.5	15	15	15	15.5	18.5
KF	M6	M6	M8	M8	M10	M10	M12	M12
LA (0/-0.1)	4.1	4.1	5	5	5	5	/	/
MM (f 7) Ø	10	10	12	12	16	16	20	25
PL (+0.1/0)	5.5	6	7.5	8	8	8	8	8
PM	/	2	3	/	/	/	/	/
RR (min) Ø	4.1	4.1	5.1	5.1	6.6	6.6	8.4	8.4
RT	M5	M5	M6	M6	M8	M8	M10	M10
RZ (min) Ø	7.5	7.5	8.5	8.5	10.5	10.5	/	/
SW (0/-0.1)	9	9	10	10	13	13	17	22
TG (±0.2)	22	26	32.5	38	46.5	56.5	72	89
U	74	78	88	90	90	98	108	134
W	83	89	100	103	105	113	124	154
WH (±1)	6	6	7	7	8	8	10	10
Z	9	11	12	13	15	15	16	20
ZA (±0.5)	37	39	44	45	45	49	54	67
ZB (+1/0)	43	45	51	52	53	57	64	77
Weight stroke	105	110	200	270	420	550	760	1400
gr. every 5mm	10	10.5	13	17	23.5	27	37	51

Technical modifications keep in reserve !

(2020/07)



Accessories

Rod lock nut  STD	Ball joint  STD	Fork 	Fork with clips  STD	Self-aligning joint 	Valves direct mounting nut 
Ø20 - Ø25: 1200.20.06 Ø32 - Ø40: 1320.32.18F Ø50 - Ø63: 1320.40.18F Ø80 - Ø100: 1320.50.18F	Ø20 - Ø25: 1200.20.32F Ø32 - Ø40: 1320.32.32F Ø50 - Ø63: 1320.40.32F Ø80 - Ø100: 1320.50.32F	Ø20 - Ø25: 1200.20.04 Ø32 - Ø40: 1320.32.13F Ø50 - Ø63: 1320.40.13F Ø80 - Ø100: 1320.50.13F	Ø20 - Ø25: 1200.20.04/1 Ø32 - Ø40: 1320.32.13/1F Ø50 - Ø63: 1320.40.13/1F Ø80 - Ø100: 1320.50.13/1F	Ø20 - Ø25: 1200.20.33F Ø32 - Ø40: 1320.32.33F Ø50 - Ø63: 1320.40.33F Ø80 - Ø100: 1320.50.33F	1500.20.F
Flange (MF2)  STD	Foot (MS1)  STD	Rear female clevis (MP2)  STD	Narrow rear female trunnion (AB6) 	Rear male clevis (MP4)  STD	Rear male clevis (with jointed head MP6) 
Steel Ø20 - Ø25: 1540.Ø.03F Ø32 - Ø40: 1380.Ø.03F	Steel 1540.Ø.05/1F	Aluminium: 1380.Ø.09F Steel: 1320.Ø.20F	Aluminium: 1380.Ø.30F Steel: 1320.Ø.29F	Aluminium Ø20-Ø25: 1580.Ø.09/1F Ø32-Ø100: 1380.Ø.09/1F Steel Ø20-Ø25: 1580.Ø.09/2F Ø32-Ø100: 1320.Ø.21F	Aluminium: 1380.Ø.15F Steel: 1320.Ø.25F
Square angle trunnion (AB7) 	Square angle trunnion (with jointed head) 	Square angle trunnion (not specified by ISO-VDMA standard) 	Square angle trunnion (with jointed head) 	Standard trunnion (not specified by ISO-VDMA standard) 	Complete standard trunnion 
Aluminium: 1380.Ø.35F Steel: 1320.Ø.23F	Steel: 1320.Ø.27F	Aluminium: 1380.Ø.11F	Aluminium: 1380.Ø.36F Steel: 1320.Ø.26F	Aluminium: 1380.Ø.10F	Steel: 1320.Ø.22F



Miniaturised magnetic sensors Rectangular section



Sensor with 2.5 m. cable



Weight gr. 27

Sensor with cable and M8 connector



Weight gr. 15

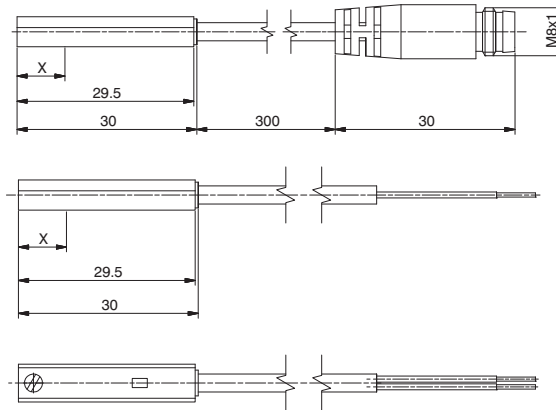

X= point of commutation

Sensor ordering codes

Ampulla Reed sensors, with led, Universal, N.O. (Normally open)		X=point of commutation	
1580.U	(2 wires) cable 2.5 mt.	15 mm	STD
MRS.U	(2 wires) cable 300 mm, M8 connector (use MC1 or MC2 connectors)	15 mm	STD
1580.UAP	PNP (3 wires) cable 2.5 mt.	15 mm	STD
MRS.UAP	PNP (3 wires) cable 300 mm, M8 connector (use MCH1 or MCH2 connectors)	15 mm	

Hall effect sensors, with led, DC, N.O. (Normally open)		X=point of commutation	
1580.HAP	PNP (3 wires) cable 2.5 mt.	8 mm	STD
1580.HAN	NPN (3 wires) cable 2.5 mt.	8 mm	
MHS.P	PNP (3 wires) cable 300 mm, M8 connector (use MCH1 or MCH2 connectors)	8 mm	STD

Diagrams and connections

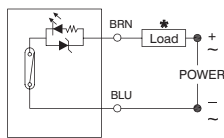

with Reed bulb (2 wires)

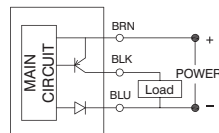

Hall-PNP effect (3 wires)

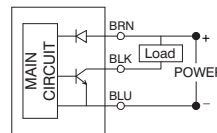

Hall-NPN effect (3 wires)

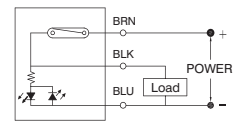

with Reed bulb (3 wires)

* The load (LOAD) can be connected either to negative or positive pole

Technical characteristics	1580.U	MRS.U	1580.UAP	MRS.UAP	1580.HAP	1580.HAN	MHS.P
Type of contact	N.O.						
Output type	PNP			NPN		PNP	
Maximum current	14 VA - 10 W		4 VA - 3 W		3 W		
Maximum permanent power	5 - 230V DC/AC		5 - 30V DC/AC		10 - 30 V DC/AC		
Voltage range	-10°C - +70°C		-10°C - +70°C				
Working temperature	3.5 V		0V **		2 V		
Maximum voltage drop	2 x 0.14 Ø3.3mm PUR	2 x 0.14 Ø3.3mm PUR	3 x 0.14 Ø3.3 mm PUR		3 x 0.14 Ø3.3 mm PUR		
Cable section (mm ²)	IP 67						
Degree of protection							

** Even if one sensor generates a voltage drop very close to 0 Volts, we suggest to connect no more than 30 sensors in series.

Cable ordering code

Connection 2 wires

Connector



Sensor



1 Brown (+)
4 Blue (-)
3 Not use

- MC1 cable 2 wires l=2.5m with M8 connector
- MC2 cable 2 wires l=5m with M8 connector
- MC3 cable 2 wires l=10m with M8 connector

Connection 3 wires

Connector



Sensor



1 Brown (+)
4 Black (signal)
3 Blue (-)

- MCH1 cable 3 wires l=2.5m with M8 connector **STD**
- MCH2 cable 3 wires l=5m with M8 connector
- MCH3 cable 3 wires l=10m with M8 connector

Basic and push/pull version



Ordering code

- 15** .Ø. stroke.
- 1 = Double acting, magnetic piston **STD**
 - 4 = Double acting, non magnetic piston
 - 10 = Basic, female threaded rod **STD**
 - 11 = Basic, male threaded rod **STD**
 - ** 12 = through rod, female threaded rod
 - 13 = through rod, male threaded rod
 - 14 = through rod, bored female threaded rod
 - 15 = through rod, bored male threaded rod
- ** It is possible to order the Ø32 and Ø40 cylinders with an aluminium piston by replacing the '1' with '2' in the ordering code.
Example: 1540.32.10.10.1 (Acetyl Resin Piston)
1540.32.10.20.1 (Aluminium Piston)
- 0 = NBR seals and C43 chromed plated rod **STD**
 - 1 = NBR seals and stainless steel rod **STD**
 - 4 = PUR seals and C43 chromed plated rod
 - 5 = PUR seals and stainless steel rod
 - 6 = FPM seals and C43 chromed plated rod
 - 7 = FPM seals and stainless steel rod
- 4 = Non-cushioned version (mechanical cushioning only)
 - 5 = Versions with adjustable end of stroke cushioning system **STD**

Bore

Ø32 - Ø40 - Ø50 - Ø63

STD STD STD STD

Basic version male piston rod

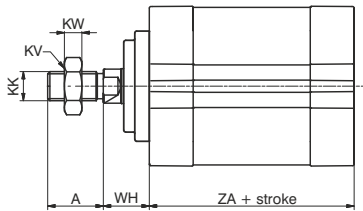

Push/pull version male rod

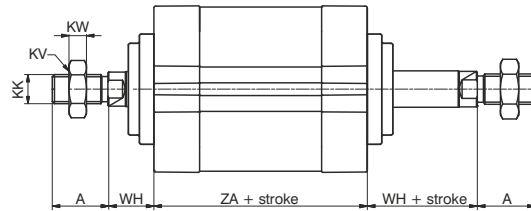

Push - pull version bored female piston rod

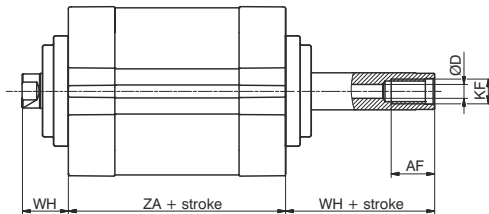

Push - pull version bored male piston rod

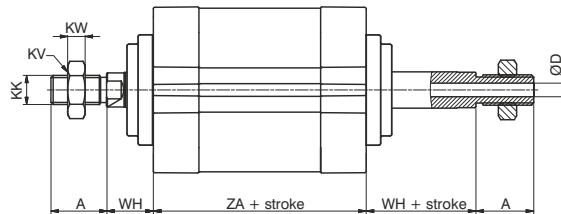

Bore	A (0/-0,5)	AF (min)	ØD	KF	KK	KV	KW	WH (±1)	ZA (±0,5)
Ø32	22	14	4,5	M8	M10x1,25	17	6	14	44
Ø40	24	18	4,5	M10	M12x1,25	19	7	14	45
Ø50	32	24	6	M12	M16x1,5	24	8	18	45
Ø63	32	24	6	M12	M16x1,5	24	8	18	49

Technical modifications keep in reserve !

(2020/07)

General

Based on the **ECOMPACT** series with piston rods and centring diameters according to ISO 15552 standard

Construction characteristics

Body	anodised aluminium
End caps	aluminium alloy casting painted with brass centring bearing
Bearing piston rod	spheroid bronze on steel band with P.T.F.E. coat
Piston rod	C43 chromed steel (on request stainless steel)
Piston	Ø32 and Ø40 acetal resin (aluminium on request)
	Ø50 and Ø63 aluminium (with FPM seals, aluminium for all of standard diameters)
Seals	standard: NBR oil resistant rubber, PUR piston rod seals (PUR or FPM on request)
Spring	stainless steel
Fixing screws	plated zinc steel

Technical characteristics

Fluid	filtered and preferably lubricated air, or non-lubricated (if air is lubricated, the lubrication must be constant)
Max. pressure	10 bar
Operating temperature	-5°C - +70°C with standard seals (magnetic or non magnetic piston)
	-30°C - +80°C with PUR seals (magnetic or non magnetic piston)
	-5°C - +80°C with FPM seals (magnetic piston)
	-5°C - +150°C with FPM seals (non magnetic piston)

Please follow the suggestions below to ensure a long life for these cylinders:

- use clean and lubricated air
- correct alignment during assembly with regard to the applied load so as to avoid radial components or bending the rod.
- avoid high speeds together with long strokes and heavy loads: this would produce kinetic energy which the cylinder cannot absorb, especially if used as a limit stop (in this case use mechanical stop device and aluminium piston)
- evaluate the environmental characteristics of cylinder used (high temperature, hard atmosphere, dust, humidity etc.)

Please note: air must be dried for applications with lower temperature.

Use hydraulic oils H class (ISO VG32) for correct continued lubrication.

Our Technical Department will be glad to help.

Stroke tolerance, minimum and maximum spring loads and cushioning length

Bore	Stroke tolerance	Minimum and maximum spring load		Cushioning length
		(N)		
(mm)	(mm)	min.	max.	(mm)
Ø32	+2 / 0 mm	19,6	25,5	6,5
Ø40		25,5	42,2	8
Ø50		44,1	96,3	7,5
Ø63	+2,5 / 0 mm	44,1	96,3	7,5

Available versions

BASIC version

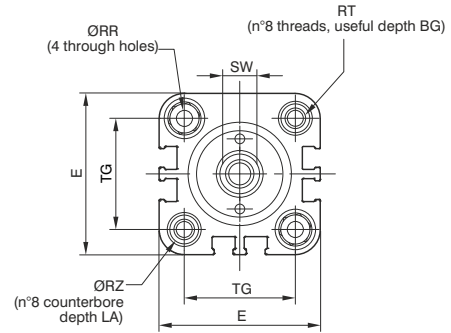
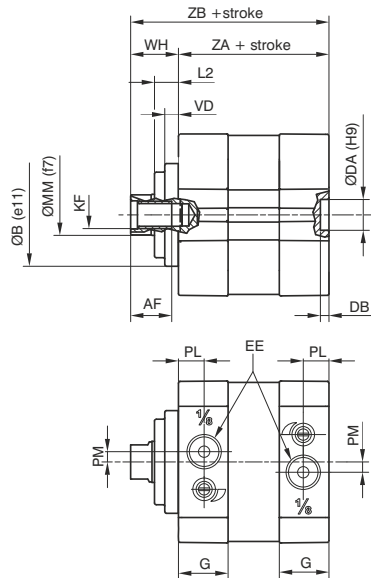

Sensor slot detail
type "B"
(n° 6 slots)

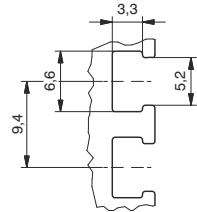

PUSH/PULL rod version

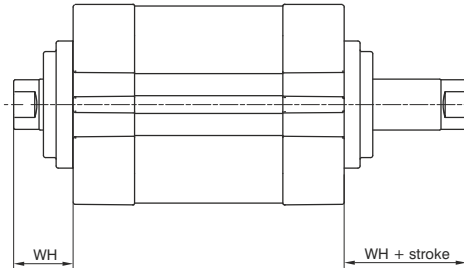









Table of dimensions

Bore	Ø32	Ø40	Ø50	Ø63	
AF (min)	12	16	20	20	
ØB (e11)	30	35	40	45	
BG	16	16	16	16	
ØDA (H9)	9	9	12	12	
DB (+0,1/0)	2,5	2,5	2,6	2,6	
E (max)	47,5	55	66	78	
EE	G1/8"	G1/8"	G1/8"	G1/8"	
G	14,5	15	15	15	
KF	M8	M10	M12	M12	
LA (0/-0,1)	5	5	5	5	
L2	7	7	10	10	
ØMM (f 7)	12	16	20	20	
PL (+0,1/0)	7,5	8	8	8	
PM	3	/	/	/	
ØRR (min)	5,1	5,1	6,6	6,6	
RT	M6	M6	M8	M8	
ØRZ (min)	8,5	8,5	10,5	10,5	
SW (0/-0,1)	10	13	17	17	
TG (±0,2)	32,5	38	46,5	56,5	
VD	4	4	5	5	
WH (±1)	14	14	18	18	
ZA (±0,5)	44	45	45	49	
ZB (+1/0)	58	59	63	67	
Weight	stroke	240	330	530	700
gr.	every 5mm	13	17	24	27

Technical modifications keep in reserve !

(2020/07)

Accessories

<p>Rod lock nut</p>  <p>STD</p> <p>Ø32: 1320.32.18F Ø40: 1320.40.18F Ø50 - Ø63: 1320.50.18F</p>	<p>Ball joint</p>  <p>STD</p> <p>Ø32: 1320.32.32F Ø40: 1320.40.32F Ø50 - Ø63: 1320.50.32F</p>	<p>Fork</p>  <p>Ø32: 1320.32.13F Ø40: 1320.40.13F Ø50 - Ø63: 1320.50.13F</p>	<p>Fork with clips</p>  <p>STD</p> <p>Ø32: 1320.32.13/1F Ø40: 1320.40.13/1F Ø50 - Ø63: 1320.50.13/1F</p>	<p>Valves direct mounting nut</p>  <p>1500.20.F</p>
<p>Self-aligning joint</p>  <p>Ø32: 1320.32.33F Ø40: 1320.40.33F Ø50 - Ø63: 1320.50.33F</p>	<p>Flange (MF2)</p>  <p>STD</p> <p>Aluminium: 1390.Ø.03FP Steel: 1380.Ø.03F</p>	<p>Foot (MS1)</p>  <p>STD</p> <p>Steel: 1540.Ø.05/1F</p>	<p>Rear female clevis (MP2)</p>  <p>STD</p> <p>Aluminium: 1380.Ø.09F Steel: 1320.Ø.20F</p>	<p>Narrow rear female trunnion (AB6)</p>  <p>Aluminium: 1380.Ø.30F Steel: 1320.Ø.29F</p>
<p>Rear male clevis (MP4)</p>  <p>STD</p> <p>Aluminium: 1380.Ø.09/1F Steel: 1320.Ø.21F</p>	<p>Rear male clevis (with jointed head MP6)</p>  <p>Aluminium: 1380.Ø.15F Steel: 1320.Ø.25F</p>	<p>Square angle trunnion (AB7)</p>  <p>Aluminium: 1380.Ø.35F Steel: 1320.Ø.23F</p>	<p>Square angle trunnion (with jointed head)</p>  <p>Steel: 1320.Ø.27F</p>	
<p>Square angle trunnion (not specified by ISO-VDMA standard)</p>  <p>Aluminium: 1380.Ø.11F</p>	<p>Square angle trunnion (with jointed head)</p>  <p>Aluminium: 1380.Ø.36F Steel: 1320.Ø.26F</p>	<p>Standard trunnion (not specified by ISO-VDMA standard)</p>  <p>Aluminium: 1380.Ø.10F</p>	<p>Complete standard trunnion</p>  <p>Aluminium: 1380.Ø.22F Steel: 1320.Ø.22F</p>	

Technical modifications keep in reserve !

(2020/07)



Miniaturised magnetic sensors Rectangular section



Sensor with 2.5 m. cable



Weight gr. 27

Sensor with cable and M8 connector



Weight gr. 15

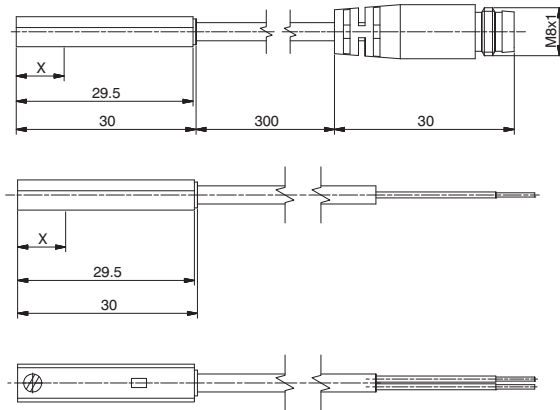

X= point of commutation

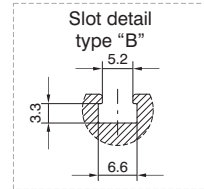

Sensor ordering codes

Ampulla Reed sensors, with led, Universal, N.O. (Normally open)			X=point of commutation
1580.U	(2 wires) cable 2.5 mt.	15 mm	STD
MRS.U	(2 wires) cable 300 mm, M8 connector (use MC1 or MC2 connectors)	15 mm	STD
1580.UAP	PNP (3 wires) cable 2.5 mt.	15 mm	STD
MRS.UAP	PNP (3 wires) cable 300 mm, M8 connector (use MCH1 or MCH2 connectors)	15 mm	

Hall effect sensors, with led, DC, N.O. (Normally open)			X=point of commutation
1580.HAP	PNP (3 wires) cable 2.5 mt.	8 mm	STD
1580.HAN	NPN (3 wires) cable 2.5 mt.	8 mm	
MHS.P	PNP (3 wires) cable 300 mm, M8 connector (use MCH1 or MCH2 connectors)	8 mm	STD

Diagrams and connections

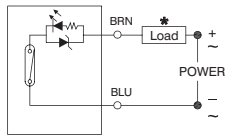

with Reed bulb (2 wires)

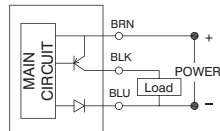

Hall-PNP effect (3 wires)

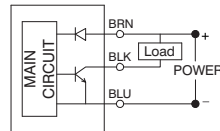

Hall-NPN effect (3 wires)

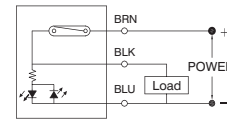

with Reed bulb (3 wires)

* The load (LOAD) can be connected either to negative or positive pole

Technical characteristics	1580.U	MRS.U	1580.UAP	MRS.UAP	1580.HAP	1580.HAN	MHS.P
Type of contact	N.O.						
Output type				PNP		NPN	PNP
Maximum current				100mA			
Maximum permanent power	14 VA - 10 W		4 VA - 3 W		3 W		
Voltage range	5 - 230V DC/AC	5 - 30V DC/AC	10 - 30 V DC/AC		10 - 30 V DC		
Working temperature	-10°C - +70°C						
Maximum voltage drop	3.5 V		0V **		2 V		
Cable section (mm ²)	2 x 0.14 Ø3.3mm PUR	2 x 0.14 Ø3.3mm PUR	3 x 0.14 Ø3.3 mm PUR		3 x 0.14 Ø3.3 mm PUR		
Degree of protection	IP 67						

** Even if one sensor generates a voltage drop very close to 0 Volts, we suggest to connect no more than 30 sensors in series.

Cable ordering code

Connection 2 wires

- MC1** cable 2 wires l=2.5m with M8 connector
- MC2** cable 2 wires l=5m with M8 connector
- MC3** cable 2 wires l=10m with M8 connector



- 1 Brown (+)
- 4 Blue (-)
- 3 Not use

Connection 3 wires

- MCH1** cable 3 wires l=2.5m with M8 connector **STD**
- MCH2** cable 3 wires l=5m with M8 connector
- MCH3** cable 3 wires l=10m with M8 connector



- 1 Brown (+)
- 4 Black (signal)
- 3 Blue (-)