

2. MICRO REGULATORS (WATER / H₂O)

| ITEM | DR02100 | DR02101 |
|--------------|--|---------|
| Port size | G 1/8" | G 1/4" |
| Media | Water, compressed air, non corrosive gases | |
| Description | Air line regulator with diaphragm and non-relieving feature | |
| Mounting | Arbitrary | |
| Supply pres. | Pe max. 25 bar | |
| Reduc. pres. | Standard : Pa 0,5-10 bar Optional : Pa 0,1-3 bar / 0,5-6 bar / 0,5-16 bar | |
| Temp. | Max. 50°C | |
| Body | Messing | |
| Fixing | Panel mounting (DR0034) Mounting bracket (MW30) | |
| Weight | 0,200 kg | |

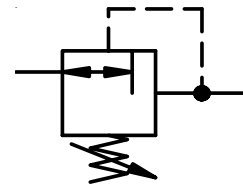
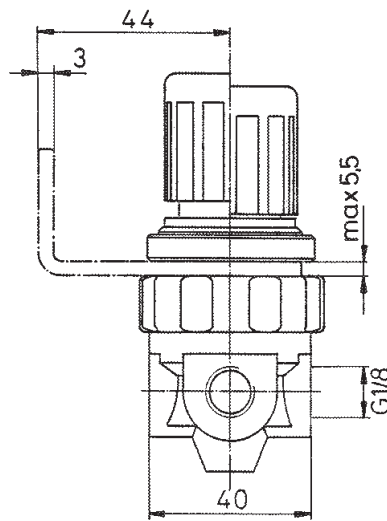
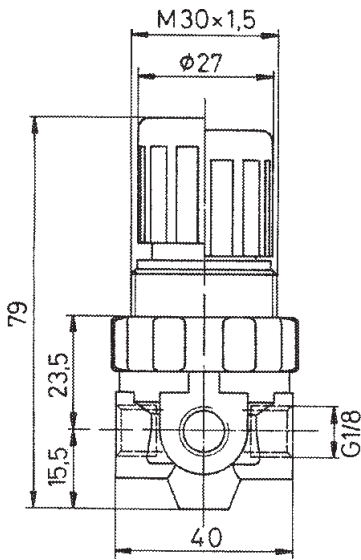

ordering indication

DR.021- ** *

| | | |
|--------------------|--|-----------------|
| type | | |
| 1 port size | | 2 option |

Port size
00 G 1/8"
01 G 1/4"

Options

example: **DR02101**

Flow characteristics (AIR)

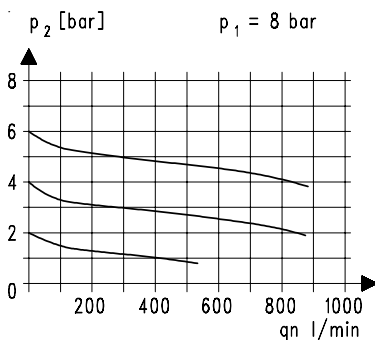

Flow characteristics (WATER)

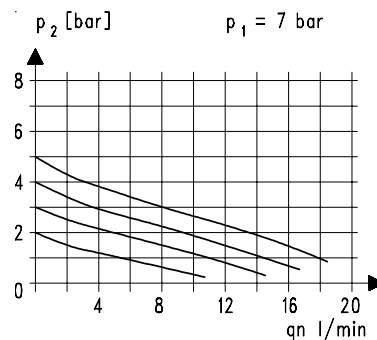

Pressure characteristics

