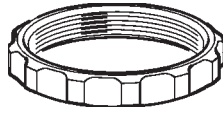
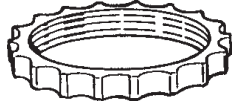
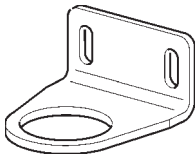
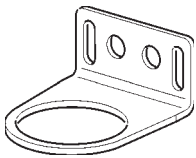
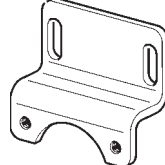
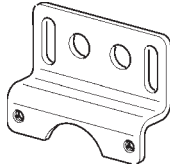
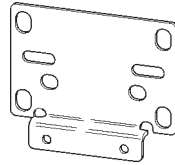
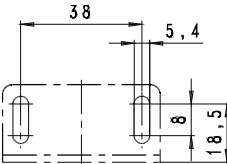
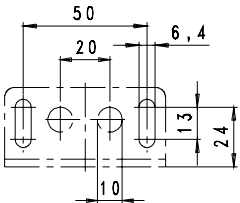
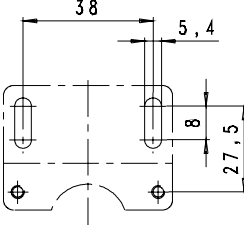
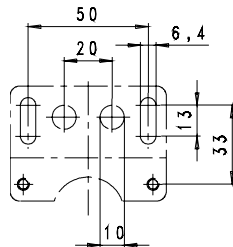
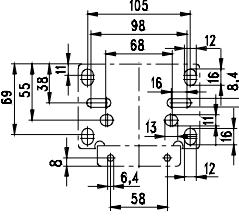

ACCESSORIES FOR AIR TREATMENT

1. MOUNTINGS

PANEL MOUNT NUTS			
Cod. <i>DR0034</i>		Cod. <i>C33-42</i>	
Dimensions (M30 x 1,5)		Dimensions (M50 x 1,5)	

MOUNTING BRACKETS				
<i>MW30</i>	<i>MW50</i>	<i>ZW11</i>	<i>ZW33</i>	<i>ZW55</i>
				
				

Technical modifications keep in reserve !

2. MULTI-FIX COUPLING KITS

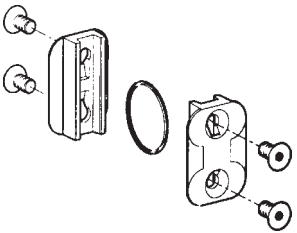
	Cod.	Used by	
	KP00	Multi-fix series Size 0 : FRL0- / CL0-	
	KP11	Multi-fix series Size 1 : FRL1- / CL1-	
	KP11Z	Multi-fix series Size 1 : Z11	
	KP33	Multi-fix series Size 3 : FRL3- / CL3-	
	KP33Z	Multi-fix series Size 3 : Z33	
	KP55	Multi-fix series Size 5 : FRL5- / CL5-	
KP55Z	Multi-fix series Size 5 : Z55		

(2004/01)

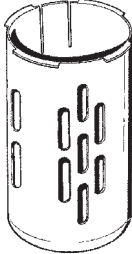

3. MULTI-FIX BOWL GUARDS

	Cod.	Used by	
	C00-45	Multi-fix series Size 0 : C0- / F0- / L0-	
	C11-45	Multi-fix series Size 1 : C1- / F1- / L1-	
	C33-45	Multi-fix series Size 3 : C3- / F3- / L3-	
		Multi-fix series Size 5 : C5- / F5- / L5-	

4. LUBRICATION OIL

	Cod.	Volume	Viscosity
	NEVOIL	5 litre	ISO 15

5. GAUGES

 <p>(Standard)</p>  <p>(Panel mounting)</p>	Type	Cod.	Con.	Build	Ø (mm)	Range (bar)	Accuracy Class
	Standard	MANOVAC	1/8"	☐ A	40	-1 / 0	2.5
	Standard	MANO-0-4-1/8"	1/8"	☐ A	40	0 / 4	2.5
	Standard	MANO-0-10-1/8"	1/8"	☐ A	40	0 / 10	2.5
	Standard	MANO-0-10-1/4"	1/4"	☐ A	50	0 / 10	2.5
	Panel mounting	MAPA-0-10B-50	1/8"	☐ A	50	0 / 10	2.5
	Non-Standard	On request	1/8"	☐ A	40	-1 / 0	1
			1/4"	⊙ O	50	0 / 1.6	1.6
			1/2"		63	0 / 2.5	2.5
					100	0 / 4	
					0 / 6		
					0 / 10		
					0 / 16		
					0 / 25		
					0 / 100		
					0 / 400		
					0 / 600		
<p><u>Options</u> : Case in steel or stainless steel, with slip ring, glycerine filled, with PSI-scale, with calibration-certificate...</p>							

Technical modifications keep in reserve !

(2015/01)