

PNEUMATIC VIBRATORS

1. BALL VIBRATORS series K



DESCRIPTION

Manufactured with a rustproof extruded aluminium body fitted with hardened steel races on which a steel ball rotates. Nylon end plates are located on either side to contain the ball and prevent the ingress of dust and water, thus allowing the unit **to be used in dusty or wet environments**. Inlet and exhaust ports have standard pipe threads, allowing the exhaust air to be piped away, ensuring that no restriction is imposed to exhaust air. Four mounting holes are provided, two vertically and two horizontally for handling difficult mounting positions.

TECHNICAL CHARACTERISTICS

- No lubrication required but clean filtered air should be used
- Noise level range 75 to 95 dBa

LEGEND

1. Extruded aluminium alloy body
2. Hardened ground steel alloy races
3. Nylon endplates
4. Hardened lapped ball
5. Air inlet
6. Air exhaust
7. Base mounting holes
8. Lateral mounting holes

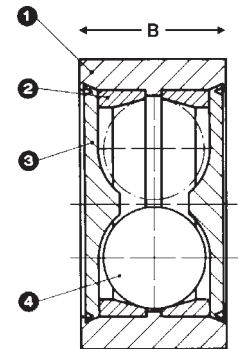
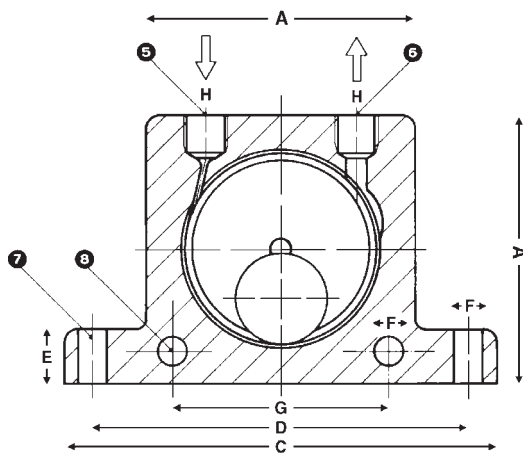

Technical modifications keep in reserve !



- Assisting the flow of material from chutes & hoppers
- Preventing bottles and similar objects from locking together & blocking conveyor systems
- Compaction of material in containers of moulds
- Separation of various sizes of material on screens

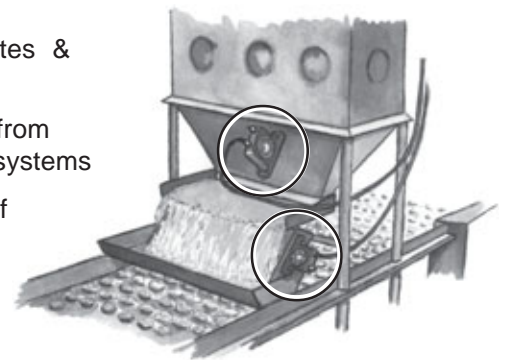

(2009/09)

COD.	Dimensions								WT (kg)	Frequency			Centrifugal force			Air consumption/min.		
	A	B	C	D	E	F	G	H		2 bar	4 bar	6 bar	2 bar	4 bar	6 bar	2 bar	4 bar	6 bar
	(mm)	(mm)	(mm)	(mm)	(mm)	(mm)	(mm)	(BSP)	(VPM)	(VPM)	(VPM)	(N)	(N)	(N)	(L)	(L)	(L)	
K8	50	20	86	68	12	7	40	1/4"	0,13	25500	31000	35000	130	260	360	83	145	195
K10										22500	28000	34000	250	470	710	92	150	200
K13	65	24	113	90	16	9	50	1/4"	0,26	15000	18500	22500	320	550	870	94	158	225
K16		27																
K20	80	33	128	104	16	9	60	1/4"	0,53	10500	14500	16500	720	1220	1720	130	230	340
K25		38																
K30	100	44	160	130	20	11	80	3/8"	1,13	7800	9700	12500	1510	2470	3210	215	375	570
K36		50																

2. TURBINE VIBRATORS series GT

CONSTRUCTION

Vibration from the centrifugal force of positive and negative unbalanced torques in the rotor.
Rotor on two pre-lubricated and enclosed ball bearings arranged in pairs. Lubricated with special grease for long life.



TECHNICAL CHARACTERISTICS

- Lubrication free
- **Extremely quiet** (60 to 75 dBa)
- Strong vibration from high speeds and eccentric working torques
- Continuously variable (compressed air)
- Can be used at temperatures up to 150°C
- Resistant to extreme environmental conditions

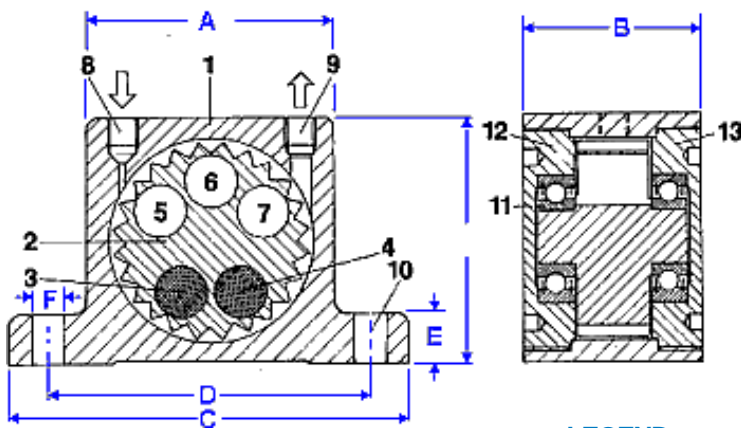

LEGEND

- 1 - Housing made from extruded aluminium alloy
- 2 - Turbine wheel made from surface-hardened aluminium
- 3-4 - High-density inserts: positive torque
- 5-7 - Openings for achieving negative torque
- 8 - Air inlet (BSP thread, will accept NPT)
- 9 - Air exhaust (BSP thread, will accept NPT)
- 10 - Base mounting holes
- 11 - Pre-lubricated and enclosed ball bearings arranged in pairs

Surface-hardened aluminium end plates

- 12 - with left-hand thread
- 13 - with right-hand thread

COD.	Dimensions								Frequency			Centrifugal force			Air consumption/min.		
	A	B	C	D	E	F	CON	WT	2 bar	4 bar	6 bar	2 bar	4 bar	6 bar	2 bar	4 bar	6 bar
	(mm)	(mm)	(mm)	(mm)	(mm)	(mm)	(BSP)	(kg)	(VPM)	(VPM)	(VPM)	(N)	(N)	(N)	(L)	(L)	(L)
GT8	50	33	86	68	12	7	1/8"	0,26	36000	42000	46000	990	2060	2910	46	80	112
GT10									27500	35000	37500	840	1390	2400			
GT13	65	42	113	90	16	9	1/4"	0,58	26000	30000	33000	1400	2440	3730	120	200	290
GT16									17000	21500	24000	1220	2090	3160			
GT20	80	56	128	104	16	9	1/4"	1,12	17000	20000	23000	2170	4040	5520	185	325	455
GT25									12000	15500	17000	2120	3510	5070			
GT30	100	73	160	130	20	11	3/8"	2,5	13000	14000	16000	3380	5430	7540	330	530	745
GT36									8000	10000	13000	3290	5360	7190			

Technical modifications keep in reserve !

(2009/09)

3. PISTON VIBRATORS series FP

DESCRIPTION



The FP-series pneumatic vibrators produce a linear vibration with an infinitely variable amplitude and frequency. The frequency is controlled by the air pressure.

A spring is used in the vibrator body to help starting. Minimum operating pressure is 2 bar.

The aluminium body is hard coated and is corrosion resistant. The power-to-weight ratio of the unit makes it particularly efficient for feeder applications. **Explosion proof, light weight, compact, quiet and efficient**, these units are ideal for most applications.

TECHNICAL CHARACTERISTICS

- Lubrication recommended for optimal performance
- Noise level range 57 to 80 dBa

LEGEND

1. Hard anodised aluminium alloy body
2. Leaded bronze piston
3. Starter spring
4. Air inlet
5. Sound absorbing exhaust system
6. Hard anodised aluminium alloy socket
7. Threaded base for mounting
8. Plastic end cap
9. Air outlet

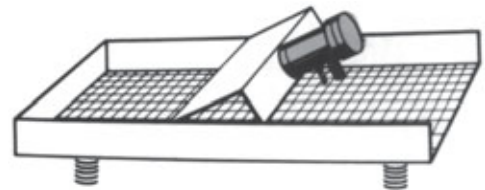
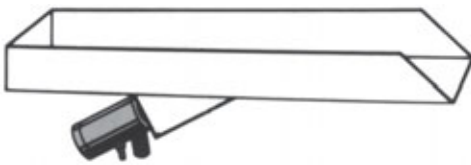
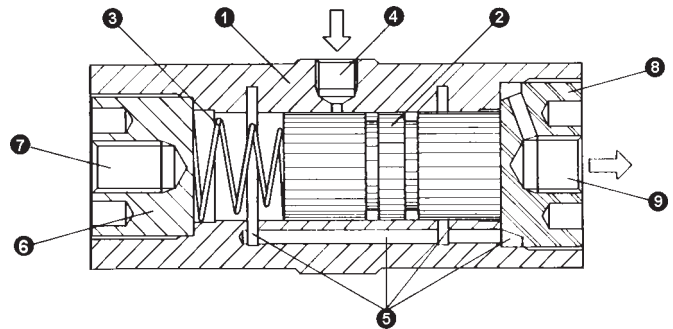
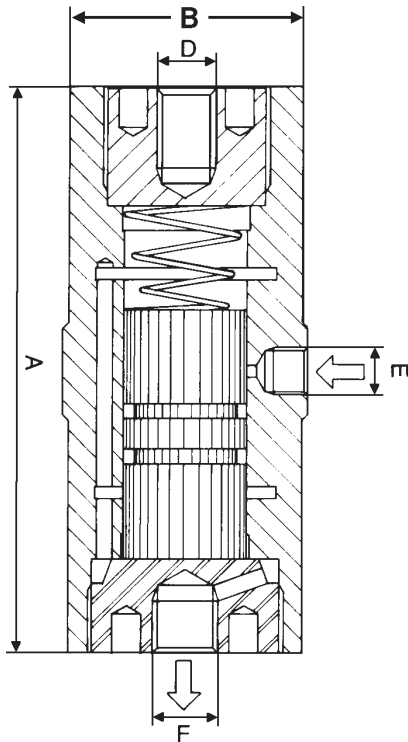

COD.	Dimensions						Frequency			Linear force			Air consumption/min.		
	A	B	D	E	F	WT	2 bar	4 bar	6 bar	2 bar	4 bar	6 bar	2 bar	4 bar	6 bar
	(mm)	(mm)	(mm)	(BSP)	(BSP)	(kg)	(VPM)	(VPM)	(VPM)	(N)	(N)	(N)	(L)	(L)	(L)
FP12L	94	31	M8	1/8"	1/8"	0.21	4000	4800	5400	32	58	81	1	3	20
FP18L	109	40	M10	1/8"	1/8"	0.41	3100	4000	4600	64	150	206	5	23	46
FP25L	136	48	M12	1/8"	1/4"	0.8	2400	3100	3700	186	392	594	18	62	93
FP35L	136	58	M12	1/4"	1/4"	1.28	2400	3100	3600	282	680	1066	38	89	135

Technical modifications keep in reserve !

(2009/09)