



WHY AIREKA

AIREKA is the new brand under which Stima S.p.A. has decided to gather a series of diverse products that share the common feature of being simple and yet innovative solutions to long-standing and complex issues, for which we believe the market does not offer adequate answers. The simplicity is the result of creative work, know-how, and extensive experience that the designers instilled in these products. So, special features make them one-of-a-kind. Always with a great focus on customers' demands.



Simian Project S.r.l. was started in 2007 as a result of the business flair and experience of Leonardo Lombardi as a designer in the automotive and packaging industries. Creativity, dynamism, and efficiency are the qualities that characterise both the products and the work methods of the company, by offering customers tailor-made solutions with quick turnaround time and high added value.

Made in Italy



■ SOME EXAMPLES AND SECTORS OF APPLICATION 6

■ PNEUMATIC COOLERS

Series VR / VRX / VR U-G	9
VR-100	12
VR-200	13
VR-300T	14
VR-300U	15
VR-200U	16
VR-400U	17
VR-400G	18
VR-600U	19
VR-600G	20
VRX-100	21
VRX-300	22
VRX-500	23
VRX-1000	24
ACCESSORIES	25
CONTROL UNIT XTRONIC2	26
CONTROL UNIT 345 B	27
CONTROL UNIT 345 T	28
EXAMPLES OF INSTALLATIONS	29
■ ELECTRONICALLY-CONTROLLED PNEUMATIC COOLERS	
Series XTRONIC	30
VRX-100 XTRONIC	31
VR-200U XTRONIC	32
VRX-300 XTRONIC	33
VR-400U XTRONIC	34
VRX-500 XTRONIC	35
VRX-1000 XTRONIC	36
SPECIAL VERSIONS AND APPLICATIONS	37
COOLER AIR SAVING	38

■ AIR KNIVES

Series ABT / ABX / ABZ	43
ABT-030	45
ABT-030 PLUS	46
ABT-060	47
ABT-100	48
ABT-200	49
ABT-240	50
ABT-400	51
ABT-600	52
ABT-800	53
ACCESSORIES - SPECIAL VERSIONS	54
ABT-F1C	55
ABX-1000	56
ABX-1500	57
ABX-2000	58
ABZ-1000	59
ABZ-1500	60
ABZ-2000	61

■ AIR AMPLIFIERS

Series AM-T	63
AM-10T	64
AM-15T	65
AM-20T	66
AM-25T	67
AM-30T	68
AM-40T	69
AM-50T	70
ACCESSORI	71
SPECIAL APPLICATIONS	72
AIR-SPEED 25	72
AIRCLEAN 30	73

■ SPECIAL NOZZLES

Series UGP / UGL / UGD / UGF / UGB	74
UGP 20A / UGP 20B	75
UGP 45A / UGP 45B	76
UGL	77
UGD 18-I	78
UGD 08 / UGD 12 / UGD 18 / UGD 30	79
UGF 03 / UGF 04 / UGF 05 / UGF 06	80
UGB 100 / UGB 300	81

■ CONDENSATE SEPARATORS

Series HSC	83
HSC - T2	84
ACCESSORIES	85

■ PICTURES OF APPLICATIONS 86

The screenshot shows the AIREKA website interface. At the top, there is a navigation menu with 'HOME', 'PRODUCTS', 'FOCUS', 'COMPANY', and 'CONTACTS'. Below the menu, there are five product categories with 'VIEW PRODUCTS' buttons: Pneumatic Coolers, Air Knives, Air Amplifiers, Special Nozzles, and Condensate Separators. On the right side, a large image of an air amplifier device is displayed. The device is a rectangular metal unit with various ports and a label that reads 'www.aireka.it' and 'Sima S.p.A. Via Guido 33/35 40050 Fiume di Argenteo (BO) +39 051 8651911'.

AIREKA devices are designed to meet the requirements of OEMs and end-users in the field of automation and in every industry.

They stand out in the market because of:

- Unique and innovative design;
- High performances;
- Robustness, simplicity of use, and high reliability;
- Customised versions (in dimensions and materials) easily available;
- High quality standards and scrupulous tests;
- Employ of electronics on many devices.

For more information, you can also check our website: www.aireka.it



EXAMPLES OF SECTORS OF APPLICATION



PNEUMATIC COOLERS

- **MACHINE TOOLS / MACHINING**
Cooling of machined parts and of tools: milling, turning, cutting, etc.; cooling of blades and saws, etc.
- **AUTOMATIC MACHINERY / PACKAGING**
Cooling of control cabinets, of closing points of bags, of welding points, of glues, of foils for packaging, of control displays, of touch panels, etc.
- **COMPOSITE MATERIALS**
Tooling, machining, etc.; carbon fibres' processing.
- **MOULDING**
Both for plastics and metals. Cooling of moulds, sprues, and moulded parts.
- **AUTOMOTIVE**
Cooling of plastic components.
- **FOUNDRIES**
Cooling of moulds and workpieces.
- **PRESSES**
Cooling of electric motors and of parts of the press itself.
- **PAPER PROCESSING**
Cooling of blades.
- **TEXTILE**
Cooling of needles.
- **LASER CUTTING**
- **TUBES EXTRUSION**
- **LINEAR MOTORS.**

AIR KNIVES

- **PACKAGING**
Cleaning of parts on conveyor belts, opening of plastic bags, blowing plastic films, etc.
- **MACHINE TOOLS / MACHINING**
To clean and dry machined parts, cleaning of machine windows, etc.
- **WOODWORKING**
To clean panels, to blow-off chips, etc.
- **AUTOMOTIVE**
Cleaning and drying of vehicles' bodies before finishing.
- **FINISHING**
Drying of surfaces before painting.
- **FOODSTUFFS**
Drying of bottles after filling, to clean vegetables, to clean photocells and optical sensors.
- **PAPER PROCESSING**
Sheeting, browsing of foils, to remove scraps, etc.
- **TILES / CERAMICS**
To dry and clean tiles.
- **INDUSTRIAL LAUNDERING**
To dry parts.



AIR AMPLIFIERS

- **PACKAGING / AUTOMATIC MACHINERY**
To convey granules, tobacco, coffee powder, etc., to either blow-off and suction shavings.
- **MACHINE TOOLS**
To blow-off shavings and scraps, to empty tanks of emulsified water, etc.
- **WOODWORKING**
To blow-off chips.
- **WELDING**
Aspiration of fumes and gases
- **PHARMACEUTICAL**
Conveying of pills.
- **WIRES EXTRUSION**
To clean the wire.
- **3D PRINTERS**
Conveying of plastic granules.



SPECIAL NOZZLES

- **DEVICES FOR BLOW-OFF AND CLEANING**
Automatic machinery, metal processing, plastic industry, woodworking, ceramic, marble processing.



```

elif operation == "MIRROR_Z":
    mirror_mod.use_x = False
    mirror_mod.use_y = False
    mirror_mod.use_z = True

#selection at the end -add back the deselected mirror modifier object
mirror_ob.select= 1
modifier_ob.select=1
bpy.context.scene.objects.active
    
```

Description of the set-up and instrumentation used for our tests on pneumatic coolers.

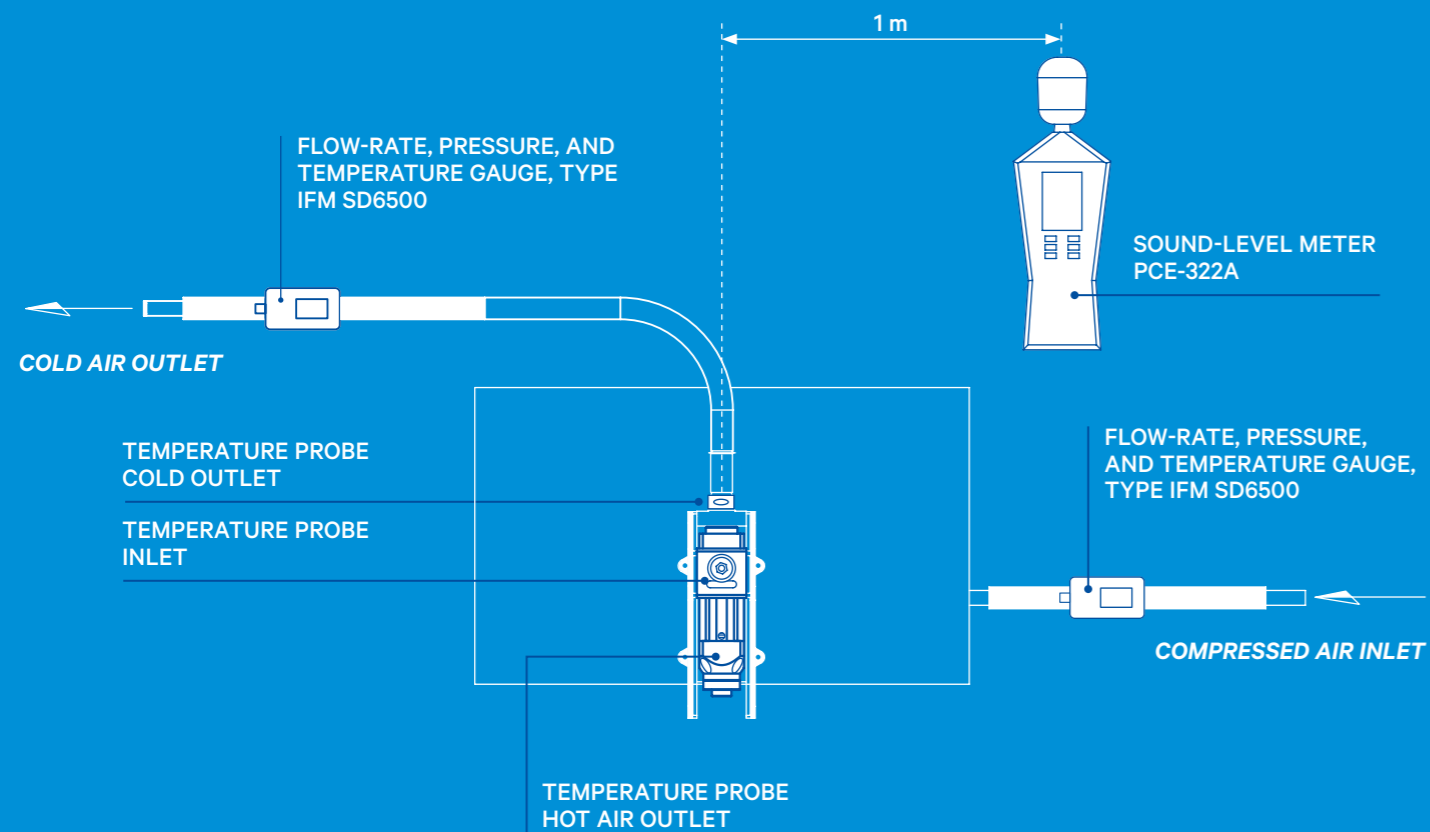

The **VR / VRX / VR U-G SERIES** coolers are state-of-the-art solutions for compressed-air cooling based on the principle of the Vortex Tube. The excellent performances of flow-rate and ΔT generated, the design, the fastenings that make them extremely versatile to mount, and the possibility to combine them in a patented system with the air amplifiers (to use the hot air flow), offer customers an innovative, effective, and inexpensive solution to cool down metal and plastic parts, electric and electronic control cabinets, and mechanical applications. All this with a simple connection to the compressed-air line.

- ΔT up to -40°C for the cold flow and $+60^{\circ}\text{C}$ for the hot flow, in comparison to the temperature of air at inlet
- Easy to install, thanks to flanges and magnetic supports
- Patented system of hot air's recovery to actuate an amplifier/conveyor
- Made of corrosion-resistant materials
- No moving part, so not subject to wear and tear
- No electricity or chemical substances required
- They do not cause either sparkles or interferences
- Instant operation
- Reliable and maintenance-free



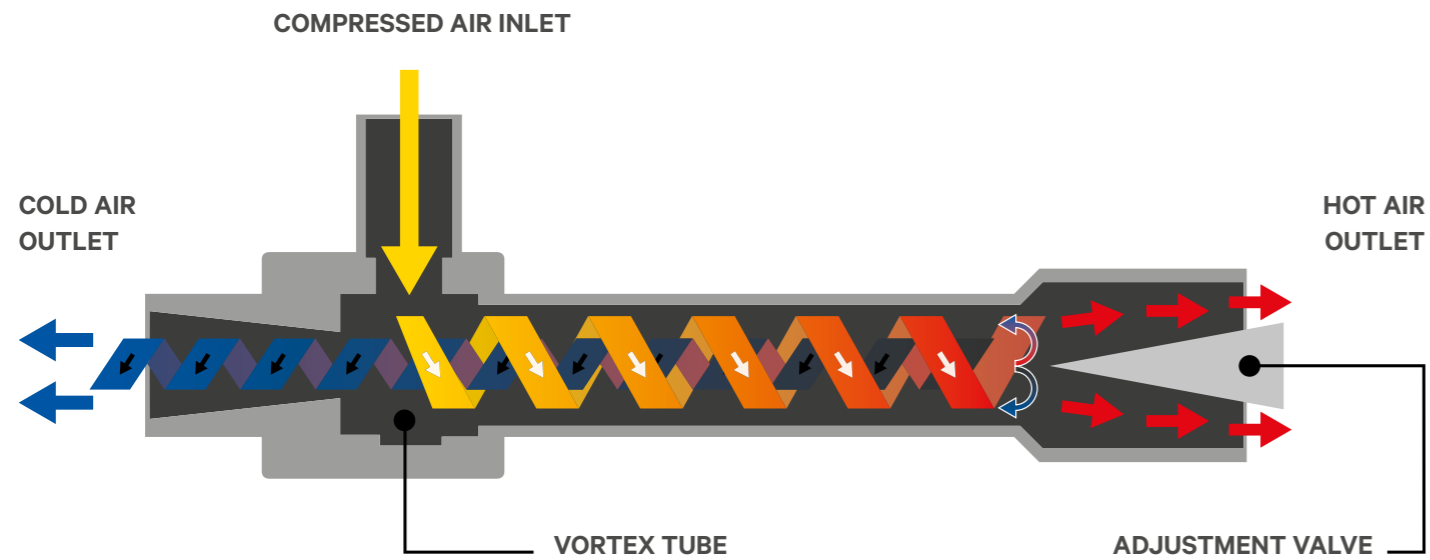

Ranque-Hilsch tube (Vortex tube)

DESCRIPTION OF VORTEX TUBES

The Ranque-Hilsch tube, in the industrial sector better known as “Vortex tube”, is a device that splits a compressed-air flow in 2 separate streams: one of cold air, and one of hot air.

The core of the system is the vortex chamber, which is connected to 2 opposed tubes, one of which features a valve. When the compressed air is injected tangentially in the chamber, this causes the rotary movement of air towards one of the exits. This vortex moves rotating at high speed and brushing against the inner side of the tube, increasing in temperature; the valve placed at the hot air outlet enables some of it to be exhausted. The remaining part goes back, creating a low pressure vortex moving towards the other exit and giving away heat to the first vortex. So, this flow is much colder.

The ΔT generated is inversely proportional to the volume of the flow. The differences in temperature are considerable and can reach -40°C for the cold flow and 60°C for the hot flow.

In the industrial field the Vortex tubes have been employed for a long time and have found a variety of applications in which they offer a major added value. They have great cooling performances, are very easy to install and have instant operation, have no moving part and therefore are maintenance-free. Plus, they do not require electric power, so they are suitable for dangerous environments and humid areas.

If the application enables their use, they are price-worthier than electric coolers. Our coolers SERIES VR and VRX, beside the excellent performances in comparison to the other products in the market, were designed to be easily customised according to customers' demands.

SERIES VR-100

MODULAR PNEUMATIC COOLERS

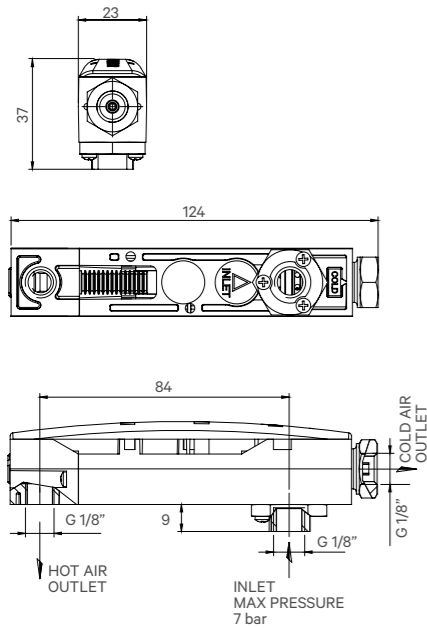

GENERAL FEATURES - VR-100

Materials	Body and cover: Nylon 6.6 Air connections and nozzles: brass
Air inlet port	G-1/8" F
Outlet port (cold flow)	G-1/8" F
Exhaust port (hot flow)	G-1/8" F
Recommended hose	Ø-8x1
Air supply pressure	3 ÷ 7 bar
Cooling power*	120 W - 100 Kcal/h - 400 BTUH
Optional magnetic support	KACM-VR100

*with inlet pressure 7 Bar and inlet temperature 20°C

PERFORMANCES AND CONSUMPTION TABLE (with air temperature at inlet 20°C)

Pressure bar	Outlet temperature cold flow °C	Consumption NL/min
1	-1.5	32
2	-8	53
3	-15	74
4	-21.5	94
5	-24.5	115
6	-26.5	135
7	-28	154

SERIES VR-200

MODULAR PNEUMATIC COOLERS

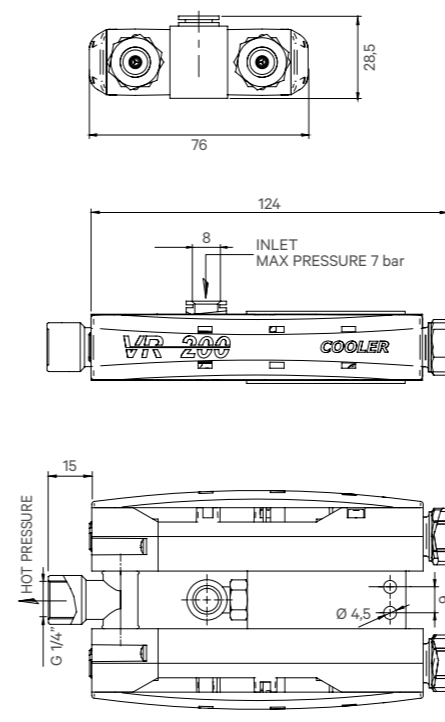
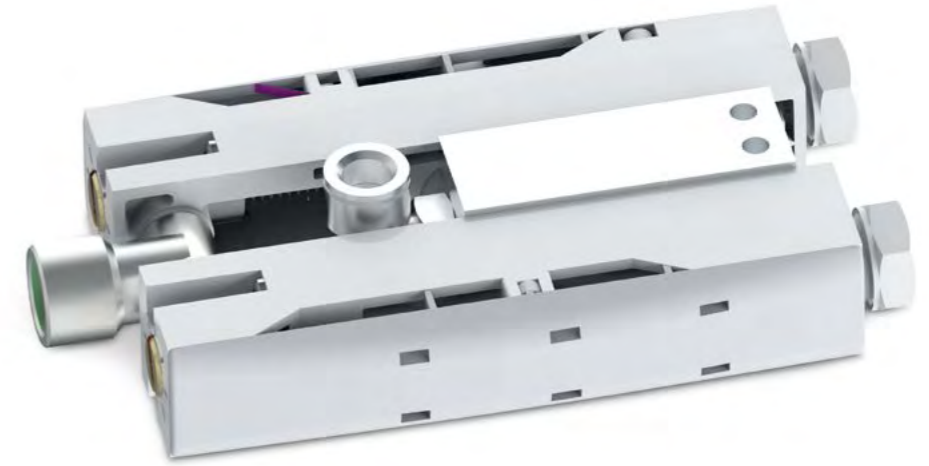

GENERAL FEATURES - VR-200

Materials	Body and cover: Nylon 6.6 Air connections and nozzles: brass
Air inlet port	Push-in fitting Ø-8x6
Outlet port (cold flow)	2 x G-1/8" F
Exhaust port (hot flow)	2 x G-1/8" F
Recommended hose	Ø-8x1
Air supply pressure	3 ÷ 7 bar
Cooling power*	240 W - 200 Kcal/h - 800 BTUH
Optional magnetic support	KACM-VR200

*with inlet pressure 7 Bar and inlet temperature 20°C

PERFORMANCES AND CONSUMPTION TABLE (with air temperature at inlet 20°C)

Pressure bar	Outlet temperature cold flow °C	Consumption NL/min
1	-1.5	64
2	-8	106
3	-15	148
4	-21.5	196
5	-24.5	230
6	-26.5	270
7	-28	308

SERIES VR-300T • 3 OUTLETS

MODULAR PNEUMATIC COOLERS

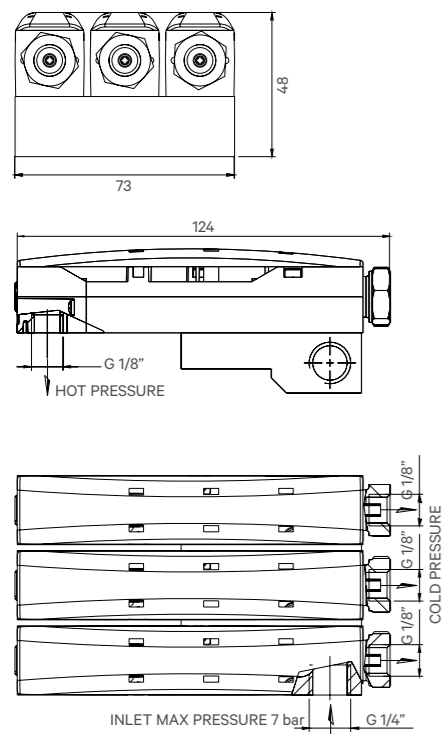

GENERAL FEATURES - VR-300T

Materials	Body and cover: Nylon 6.6 Air connections and nozzles: brass
Air inlet port	G-1/4" F
Outlet port (cold flow)	3 x G-1/8" F
Exhaust port (hot flow)	3 x G-1/8" F
Recommended hose	Ø-8x1
Air supply pressure	1 ÷ 7 bar
Cooling power*	360 W - 300 Kcal/h - 1200 BTUH
Optional magnetic support	KACM-VR300

*with inlet pressure 7 Bar and inlet temperature 20°C

PERFORMANCES AND CONSUMPTION TABLE (with air temperature at inlet 20°C)

Pressure bar	Outlet temperature cold flow °C	Consumption NL/min
1	-1,5	96
2	-8	159
3	-15	222
4	-21,5	282
5	-24,5	345
6	-26,5	405
7	-28	462

SERIES VR-300U • SINGLE OUTLET

MODULAR PNEUMATIC COOLERS

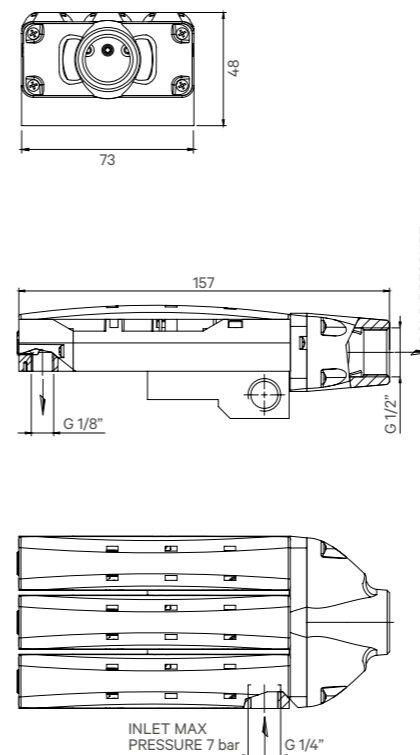

GENERAL FEATURES - VR-300U

Materials	Body and cover: Nylon 6.6 Air connections and nozzles: brass
Air inlet port	G-1/4" F
Outlet port (cold flow)	1 x G-1/2" F
Exhaust port (hot flow)	3 x G-1/8" F
Recommended hose	Ø-8x1
Air supply pressure	3 ÷ 7 bar
Cooling power*	360 W - 300 Kcal/h - 1200 BTUH
Optional magnetic support	KACM-VR300

*with inlet pressure 7 Bar and inlet temperature 20°C

PERFORMANCES AND CONSUMPTION TABLE (with air temperature at inlet 20°C)

Pressure bar	Outlet temperature cold flow °C	Consumption NL/min
1	-1,5	96
2	-8	159
3	-15	222
4	-21,5	282
5	-24,5	345
6	-26,5	405
7	-28	462

SERIES VR-200U • SINGLE OUTLET

HIGH-PERFORMANCE COMPACT PNEUMATIC COOLERS

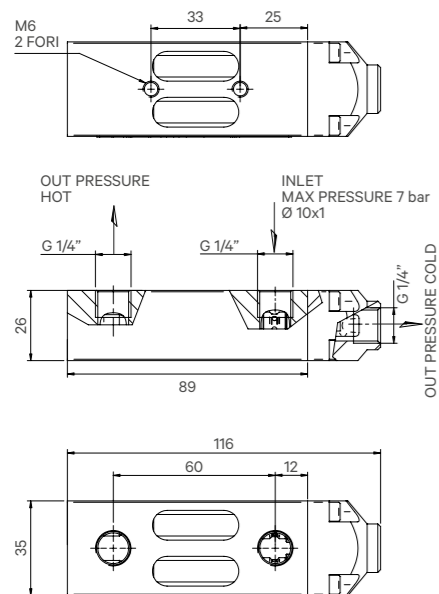

GENERAL FEATURES - VR-200U

Materials	Body and cover: Delrin Ports and nozzles: Brass
Air inlet port	G-1/4" F
Outlet port (cold flow)	G-1/4" F
Exhaust port (hot flow)	G-1/4" F
Recommended hose	Ø-8x1
Air supply pressure	max 7 bar
Cooling power*	264 W - 220 Kcal/h - 880 BTUH
Optional magnetic support	By means of 2 threads M6 on the body
Weight	210 g

* With inlet pressure 7 Bar and inlet temperature 20°C.

PERFORMANCES AND CONSUMPTION TABLE (with air temperature at inlet 20°C)

Pressure bar	Outlet temperature cold flow °C	Consumption NL/min	Noise level* dBA
1	-2	64	50
2	-12	106	54
3	-18	148	58
4	-23	188	61
5	-26	230	65
6	-28	270	68
7	-31	308	70

*Test made with insulated LOC-LINE flexible tube at cold outlet, and tube L= 1 m at hot air outlet.

SERIES VR-400U • SINGLE OUTLET

HIGH-PERFORMANCE COMPACT PNEUMATIC COOLERS

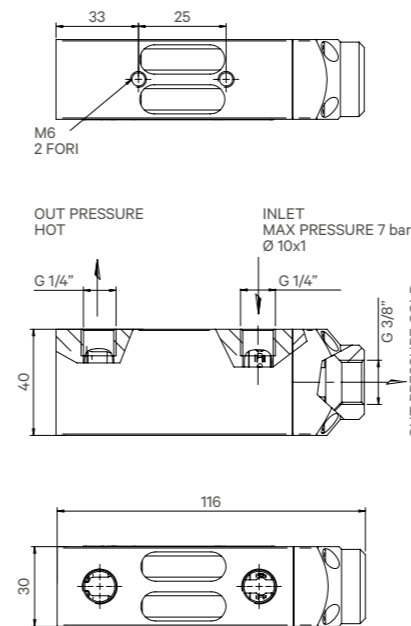

GENERAL FEATURES - VR-400U

Materials	Body and cover: Delrin Ports and nozzles: Brass
Air inlet port	G-1/4" F
Exhaust port (hot flow)	G-1/4" F
Recommended hose	Ø-10x1
Supply pressure	max 7 bar
Cooling power*	528 W - 440 Kcal/h - 1760 BTUH
Optional fixation of magnetic kit	By means of 2 threads M6 on body
Weight	285 g

* With inlet pressure 7 Bar and inlet temperature 20°C.

PERFORMANCES AND CONSUMPTION TABLE (with air temperature at inlet 20°C)

Pressure bar	Outlet temperature cold flow °C	Consumption NL/min	Noise level* dBA
1	-2	128	55
2	-12	212	60
3	-18	296	64
4	-23	376	67
5	-26	460	70
6	-28	540	71
7	-31	616	73

*Test made with insulated LOC-LINE flexible tube at cold outlet, and tube L= 1 m at hot air outlet.

SERIES VR-400G • TO COOL DOWN BLADES, BELTS, AND BANDS

HIGH-PERFORMANCE COMPACT PNEUMATIC COOLERS

SERIES VR-600U • SINGLE OUTLET

HIGH-PERFORMANCE COMPACT PNEUMATIC COOLERS

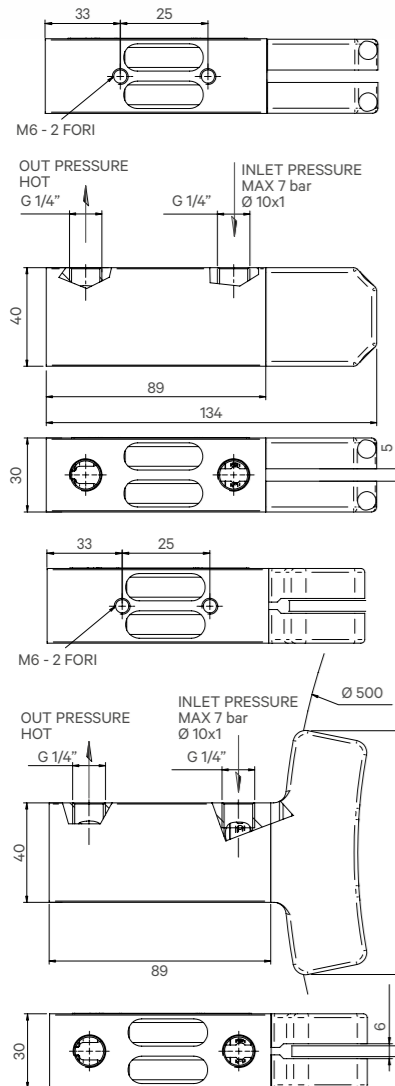

GENERAL FEATURES - VR-400G

Materials	Body: Derlin Clamps: ABS (other materials on request) Inner spindles: brass
Air inlet port	G-1/4" F
Clamps width (cold flow)	5 mm (customised dimensions on request)
Outlet port (hot flow)	G-1/4" F
Recommended hose	Ø-10x1
Air supply pressure	max 7 bar
Cooling power*	528 W - 440 Kcal/h - 1760 BTUH
Fixation	By means of two M6 threads on body
Weight	340 g

* With inlet pressure 7 Bar and inlet temperature 20°C.

PERFORMANCES AND CONSUMPTION TABLE (with air temperature at inlet 20°C)

Pressure bar	Outlet temperature cold flow °C	Consumption NL/min
1	-2	128
2	-12	212
3	-18	296
4	-23	376
5	-26	460
6	-28	540
7	-31	616

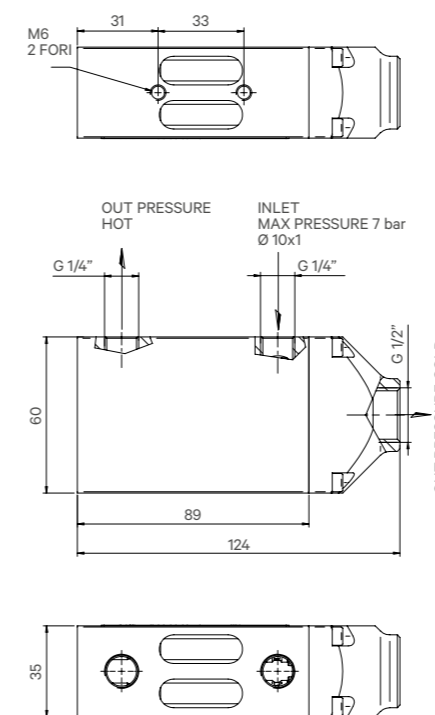

GENERAL FEATURES - VR-600U

Materials	Body: Derlin Ports and nozzles: Brass
Air inlet port	G-1/4" F
Clamps width (cold flow)	G-1/2" F
Outlet port (hot flow)	G-1/4" F
Recommended hose	Ø-10x1
Air supply pressure	max 7 bar
Cooling power*	720 W - 600 Kcal/h - 2400 BTUH
Fixation	By means of two M6 threads on body
Weight	460 g

* With inlet pressure 7 Bar and inlet temperature 20°C.

PERFORMANCES AND CONSUMPTION TABLE (with air temperature at inlet 20°C)

Pressure bar	Outlet temperature cold flow °C	Consumption NL/min	Noise level* dBA
1	-2	192	58
2	-12	318	64
3	-18	444	68
4	-23	564	72
5	-26	690	75
6	-28	810	78
7	-31	924	80

*Test made with insulated LOC-LINE flexible tube at cold outlet, and tube L= 1 m at hot air outlet.

SERIES VR-600G • TO COOL DOWN BLADES, BELTS, AND BANDS

HIGH-PERFORMANCE COMPACT PNEUMATIC COOLERS



SPECIAL VERSION FEATURING INLET FOR MINIMAL LUBRICATION

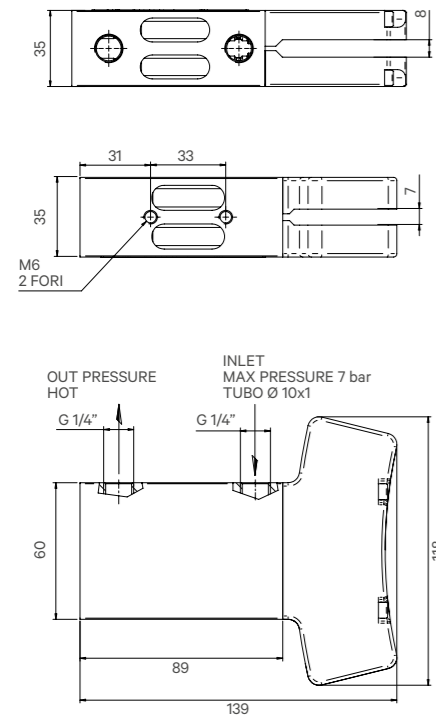

GENERAL FEATURES- VR-600G

Materials	Body: Derlin Clamps: ABS (other materials on request) Inner spindles: Brass
Air inlet port	G-1/4" F
Clamps width (cold flow)	11 mm (customised dimensions on request)
Outlet port (hot flow)	G-1/4" F
Recommended hose	Ø-10x1
Air supply pressure	max 7 bar
Cooling power*	790 W - 660 Kcal/h - 2640 BTUH
Fixation	By means of two M6 threads on body
Weight	540 g

* With inlet pressure 7 Bar and inlet temperature 20°C.

PERFORMANCES AND CONSUMPTION TABLE (with air temperature at inlet 20°C)

Pressure bar	Outlet temperature cold flow °C	Consumption NL/min
1	-2	192
2	-12	318
3	-18	444
4	-23	564
5	-26	690
6	-28	810
7	-31	924

SERIES VRX-100

HIGH-PERFORMANCE PNEUMATIC COOLERS

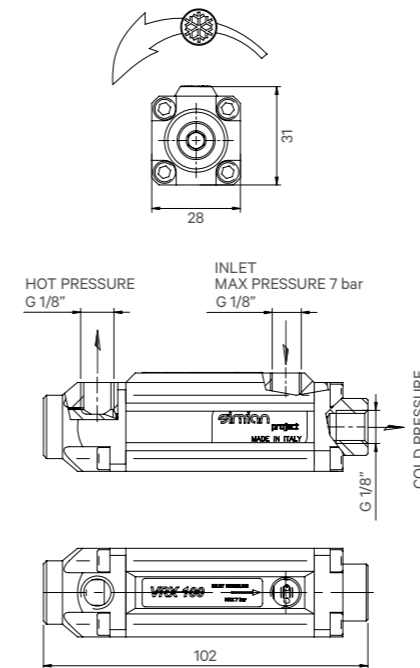

GENERAL FEATURES - VRX-100

Materials	Sleeve: anodized aluminium Ends: Nylon 6.6
Air inlet port	G-1/8" F
Outlet port (cold flow)	G-1/8" F
Exhaust port (hot flow)	G-1/8" F
Recommended hose	Ø-8x1
Air supply pressure	1 ÷ 7 bar
Cooling power*	132 W - 110 Kcal/h - 440 BTUH
Optional magnetic support	KACM-VRX-100
Weight	170 g

* With inlet pressure 7 Bar and inlet temperature 20°C.

PERFORMANCES AND CONSUMPTION TABLE (with air temperature at inlet 20°C)

Pressure bar	Outlet temperature cold flow °C	Consumption NL/min	Noise level* dBA
1	-2	32	54
2	-12	53	58
3	-18	74	62
4	-23	94	64
5	-26	115	64
6	-28	135	66
7	-31	154	68

*Test made with insulated LOC-LINE flexible tube at cold outlet, and tube L= 1 m at hot air outlet.

SERIES VRX-300

HIGH-PERFORMANCE PNEUMATIC COOLERS

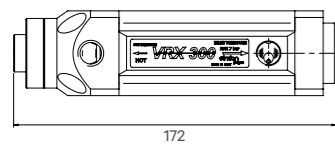
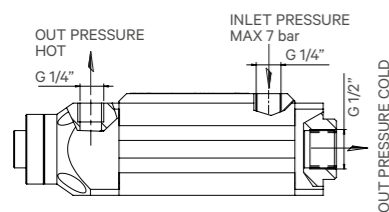
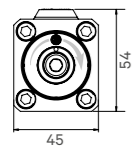

GENERAL FEATURES - VRX-300

Materials	Sleeve: anodized aluminium Ends: Delrin100
Air inlet port	G-1/4" F
Outlet port (cold flow)	G-1/2" F
Exhaust port (hot flow)	G-1/4" F
Recommended hose	Ø 10x1
Air supply pressure	1 ÷ 7 bar
Cooling power*	600 W - 523 Kcal/h - 2075 BTUH
Optional magnetic support	KACM-VRX500
Weight	740 g

* With inlet pressure 7 Bar and inlet temperature 20°C.

PERFORMANCES AND CONSUMPTION TABLE (with air temperature 20°C)

Pressure bar	Outlet temperature cold flow °C	Consumption NL/min	Noise level* dBA
1	-3	50	67
2	-7	170	72
3	-10	290	74
4	-13	410	76
5	-16	525	78
6	-17	650	80
7	-19	750	82

*Test made with insulated LOC-LINE flexible tube at cold outlet, and tube L= 1 m at hot air outlet.

SERIES VRX-500

HIGH-PERFORMANCE PNEUMATIC COOLERS

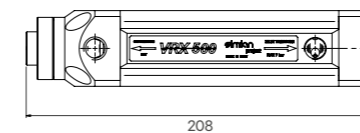
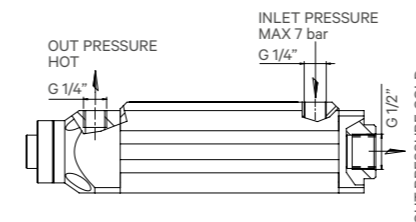
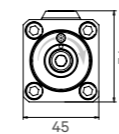

GENERAL FEATURES - VRX-500

Materials	Sleeve: anodized aluminium Ends: Delrin100
Air inlet port	G-1/4" F
Outlet port (cold flow)	G-1/2" F
Exhaust port (hot flow)	G-1/4" F
Recommended hose	Ø 10x1
Air supply pressure	1 ÷ 7 bar
Cooling power*	730 W - 630 Kcal/h - 2500 BTUH
Optional magnetic support	KACM-VRX500
Weight	860 g

* With inlet pressure 7 Bar and inlet temperature 20°C.

PERFORMANCES AND CONSUMPTION TABLE (with air temperature 20°C)

Pressure bar	Outlet temperature cold flow °C	Consumption NL/min	Noise level* dBA
1	-3	120	66
2	-7	250	71
3	-10	380	72
4	-13	500	75
5	-16	633	77
6	-17	783	78
7	-19	900	80

*Test made with insulated LOC-LINE flexible tube at cold outlet, and tube L= 1 m at hot air outlet.

SERIES VRX-1000

HIGH-PERFORMANCE PNEUMATIC COOLERS

ACCESSORIES

PNEUMATIC COOLERS

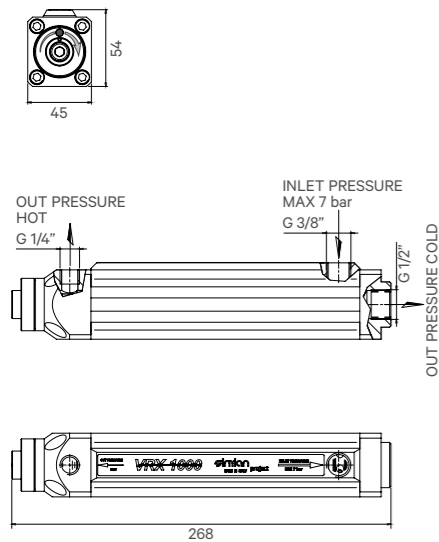

GENERAL FEATURES - VRX-1000

Materials	Sleeve: anodized aluminium Ends: Delrin100
Air inlet port	G-3/8" F
Outlet port (cold flow)	G-1/2" F
Exhaust port (hot flow)	G-1/4" F
Recommended hose	Ø 12x1
Air supply pressure	1 ÷ 7 bar
Cooling power*	1650 W - 1417 Kcal/h - 5600 BTUH
Optional magnetic support	KACM-VRX1000
Weight	1060 g

* With inlet pressure 7 Bar and inlet temperature 20°C.

PERFORMANCES AND CONSUMPTION TABLE (with air temperature at inlet 20°C)

Pressure bar	Outlet temperature cold flow °C	Consumption NL/min	Noise level* dBA
1	-3	230	70
2	-7	500	73
3	-10	800	75
4	-13	1100	77
5	-16	1424	79
6	-17	1760	81
7	-19	2025	83

*Test made with insulated LOC-LINE flexible tube at cold outlet, and tube L= 1 m at hot air outlet.



MAGNETIC SUPPORT

Part-number	Cooler
KACM-VR100	VR100
KACM-VR200	VR200
KACM-VR300	VR300
KACM-VR246	VR200U-G / VR400U-G / VR600U-G
KACM-VRX100	VRX100
KACM-VRX300 / VRX500	VRX300 / VRX500
KACM-VRX1000	VRX1000

ADJUSTABLE NOZZLE (INSULATED VERSION) FOR COLD OUTLET

Part-number	Port Ø	Nozzle Ø	No. modules	Length mm
AC28	1/8"	3	4	100
AC34	1/4"	3	4	100
AC47	3/8"	6	6	180
AC27	1/2"	6	6	180

ADJUSTABLE NOZZLE (NON-INSULATED VERSION) FOR COLD OUTLET

Part-number	Port Ø	Nozzle Ø	No. modules	Length mm
82021/8 1/8-3	1/8"	3	8	155
84041/6 1/2-9	1/2"	9	6	170

Other configurations available on request

STRAIGHT PUSH-IN FITTING FOR AIR SUPPLY

Part-number	Hose Ø	Size	Cooler
S6510	8	1/8"	VR-100 / VR-200 / VR-300 / VRX-100
S6510	10	1/4"	VRX-300 / VRX-500
S6510	12	1/4"	VRX-1000
S6510	10	3/8"	VR-600

ELBOW PUSH-IN FITTING FOR AIR SUPPLY

Part-number	Hose Ø	Size	Cooler
S6520	8	1/8"	VR-100 / VR-200 / VR-300 / VRX-100
S6520	10	1/4"	VRX-300 / VRX-500
S6520	12	1/4"	VRX-1000
S6520	10	3/8"	VR-600

SILENCER FOR HOT FLOW EXHAUST

Part-number	Size	Noise at 6 bar dBA
SC 1/8	1/8"	70
SC 1/4	1/4"	67
SC 3/8	3/8"	67

In sintered bronze.

SILENCER FOR COLD FLOW OUTLET (ITEM FOR VRX-300/VRX-500)

Codice	Size
AC25	1/2"

CONTROL UNITS XTRONIC2

1 / 2 / 3 SOLENOID VALVES

CONTROL UNITS XTRONIC 345 B

PNEUMATIC COOLERS

CONTROL UNIT XTRONIC2 C EV-1S/C



DESCRIPTION

Control box featuring:

1. Switch for automatic/manual operation
2. Solenoid valve
3. Electronic kit with 7-segment display
4. Temperature probe and safety fuses (high-temperature kit available on request).

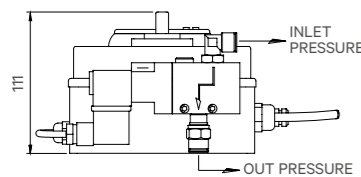

GENERAL FEATURES - XTRONIC2 (1/2/3 SOLENOID VALVES)

Supply voltage	220 V AC
Recommended hose	Ø 10x1
Supply pressure	max 7 bar
Probe length	1 m
Application	Outside of cabinets
Weight	
XTRONIC2 C-EV-1S/C (1 solenoid valve)	1300 g
XTRONIC2 C-2EV-1S/C (2 solenoid valves)	1600 g
XTRONIC2 C-3EV-1S/C (3 solenoid valves)	1900 g

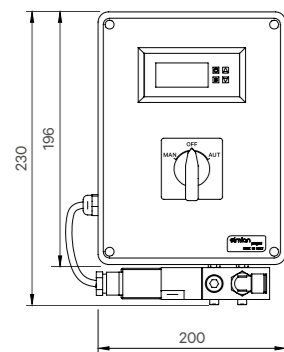

XTRONIC2 C-EV-1S/C
1 SOLENOID VALVE

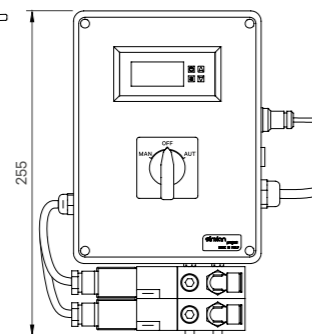

XTRONIC2 C-2EV-1S/C
2 SOLENOID VALVES

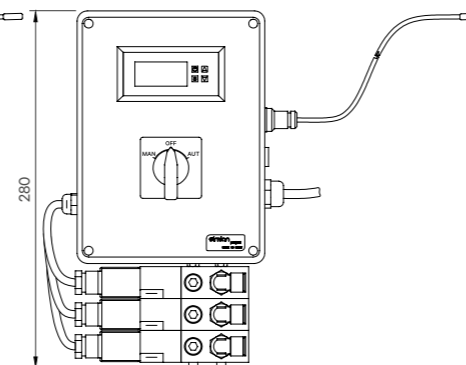

XTRONIC2 C-3EV-1S/C
3 SOLENOID VALVES



GENERAL FEATURES - XTRONIC 345 B

Supply voltage	24 V DC
Probe length	1 m
Temperature range	-20°C +60°C
Humidity range	00% 100% RH
Accuracy	0.1°C , 0.1 % RH
Current capacity	max 10 A
Coil voltage and power	24 V - 3.1 W
Electric wires' section	0.75 mm
Supply cable length	1.5 m
Application	Inside cabinets

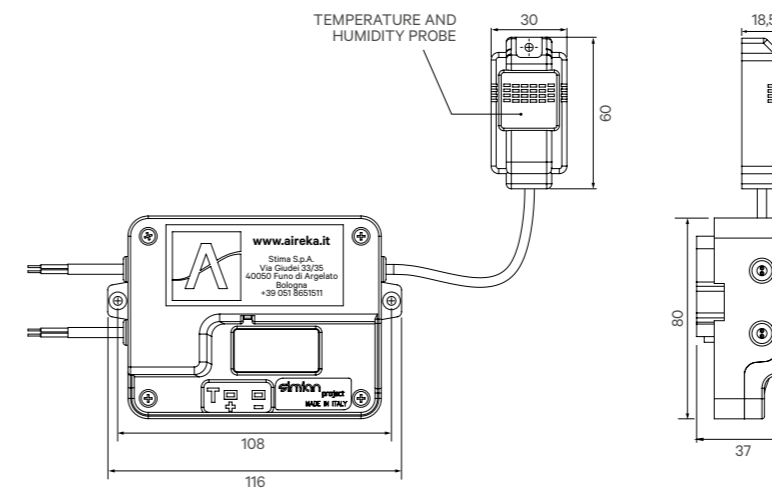



GENERAL FEATURES - XTRONIC 345 T	
Supply	24 V DC
Probe length	1 m
Time setting	Weekly / h24
Humidity range	0% - 100% RH
Accuracy	0.1°C , 0.1 % RH
Current capacity	max 10 A
Coil power	24 V - 3.1 W
Electric wires' section	0.75 mm
Application	Inside / outside

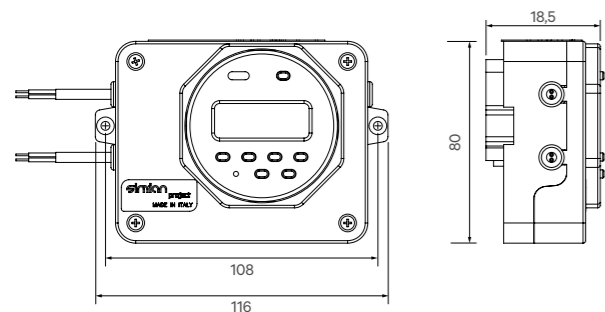

The installation of coolers in control cabinets can be of 3 types:

- EXTERNAL unit**
to have the inner temperature of the cabinet displayed directly;
- INTERNAL unit**
so that to have a compact solution;
- HYBRID systems** where the pneumatic cooler works in combination with an already existing air conditioning unit.

- Hot air
- Cold air

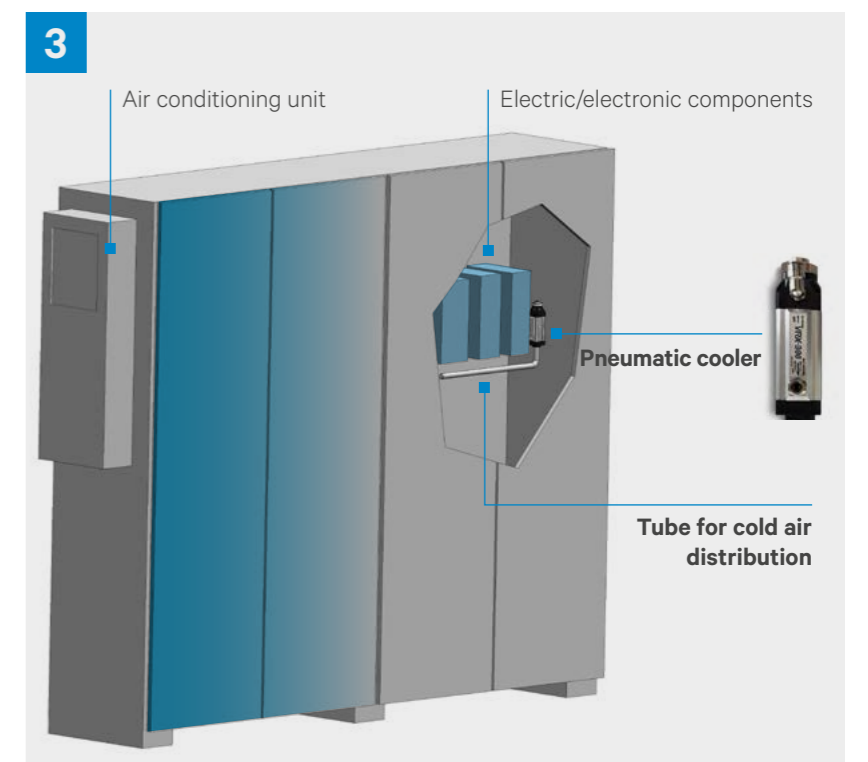
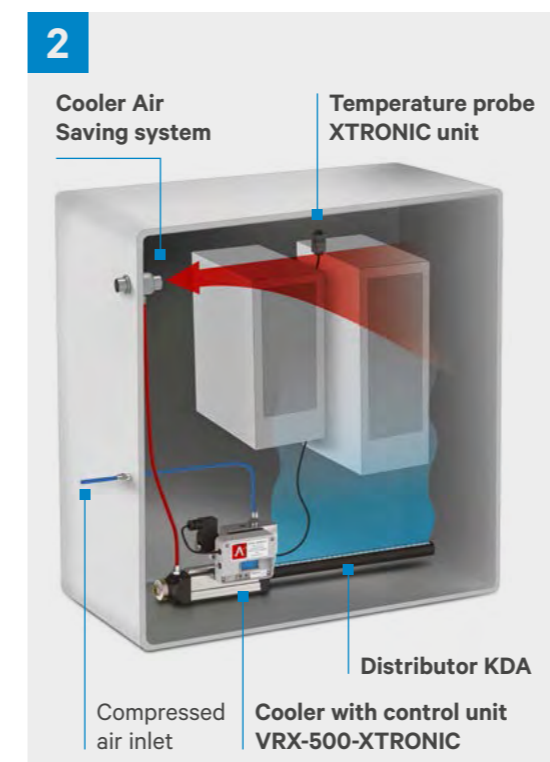
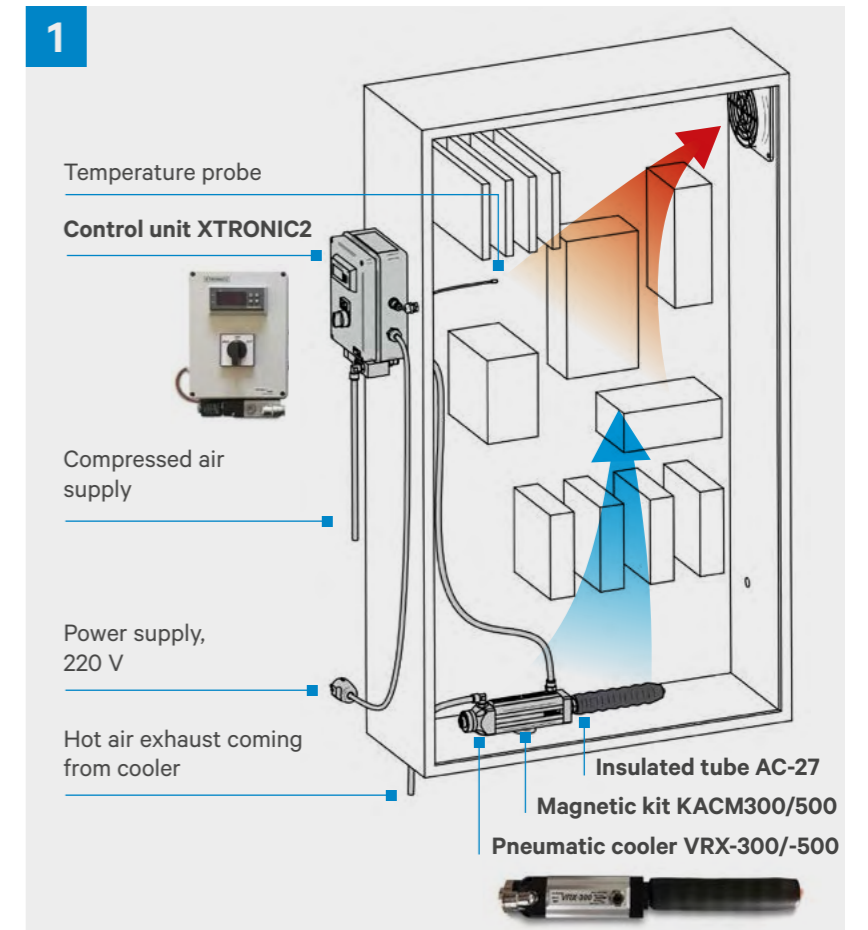

ELECTRONICALLY-CONTROLLED PNEUMATIC COOLERS

STAND-ALONE SERIES VRX-100-XTRONIC

ELECTRONICALLY-CONTROLLED PNEUMATIC COOLERS



STAND-ALONE SERIES

These are pneumatic coolers with temperature-control device, in a single unit. The market increasingly demands stand-alone devices, which are able to function autonomously, based on the parameters of the ambient temperature. Therefore, we designed and developed the **XTRONIC** temperature-control units, which are available both for remote control and installed on pneumatic coolers. So, it will be enough to place one of these electronically-controlled devices inside the enclosure that has to be cooled, connect the pneumatic hoses and the electric wires, and set the desired temperature range on the display of the unit. This way, the cooler will start working only when it is necessary, it will maintain the required refrigeration, and it will make it possible to save compressed air and energy.

Our **XTRONIC** control units can be customised too.

GENERAL FEATURES - VRX-100 XTRONIC

Supply voltage	24 V DC
Recommended hose	Ø 8x1
Supply pressure	max 7 bar
Cooling power and performances	See VRX-100 (page 21)
Probe length	1 m
Temperature range	-20°C +60°C
Humidity range	00% 100% RH
Accuracy	0.1°C , 0.1 % RH
Current capacity	max 10 A
Coil voltage and power	24 V - 3.1 W
Electric wires' section	0.75 mm
Weight	760 g

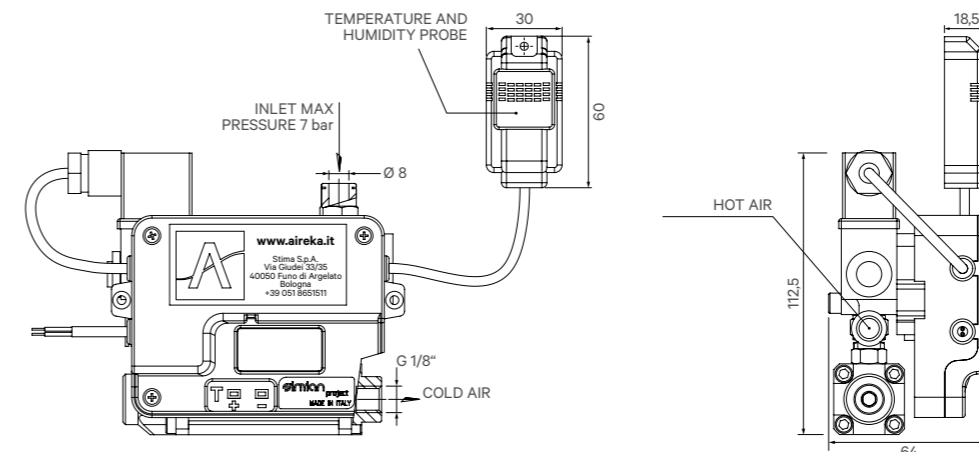

STAND-ALONE SERIES VR-200U-XTRONIC

ELECTRONICALLY-CONTROLLED PNEUMATIC COOLERS



GENERAL FEATURES - VR-200U XTRONIC

Supply voltage	24 V DC
Recommended hose	Ø 8x1
Supply pressure	max 7 bar
Cooling power and performances	See VR-200U (page 16)
Probe length	1 m
Temperature range	-20°C +60°C
Humidity range	00% 100% RH
Accuracy	0.1°C , 0.1 % RH
Current capacity	max 10 A
Coil voltage and power	24 V - 3.1 W
Electric wires' section	0.75 mm
Weight	770 g

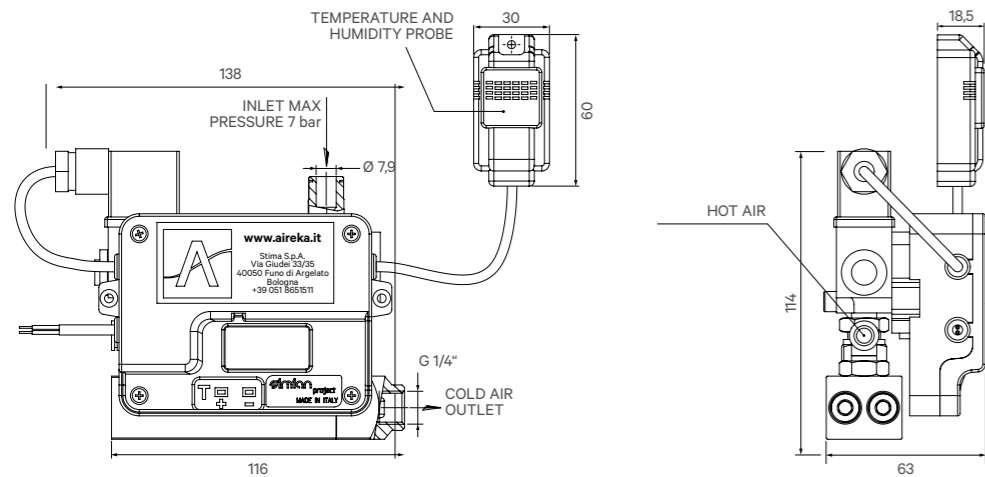

STAND-ALONE SERIES VRX-300 XTRONIC

ELECTRONICALLY-CONTROLLED PNEUMATIC COOLERS



GENERAL FEATURES - VRX-300 XTRONIC

Supply voltage	24 V DC
Recommended hose	Ø 10x1
Supply pressure	max 7 bar
Cooling power and performances	See VRX-300 (page 22)
Probe length	1 m
Temperature range	-20°C +60°C
Humidity range	00% 100% RH
Accuracy	0.1°C , 0.1 % RH
Current capacity	max 10 A
Coil voltage and power	24 V - 3.1 W
Electric wires' section	0.75 mm
Weight	1310 g

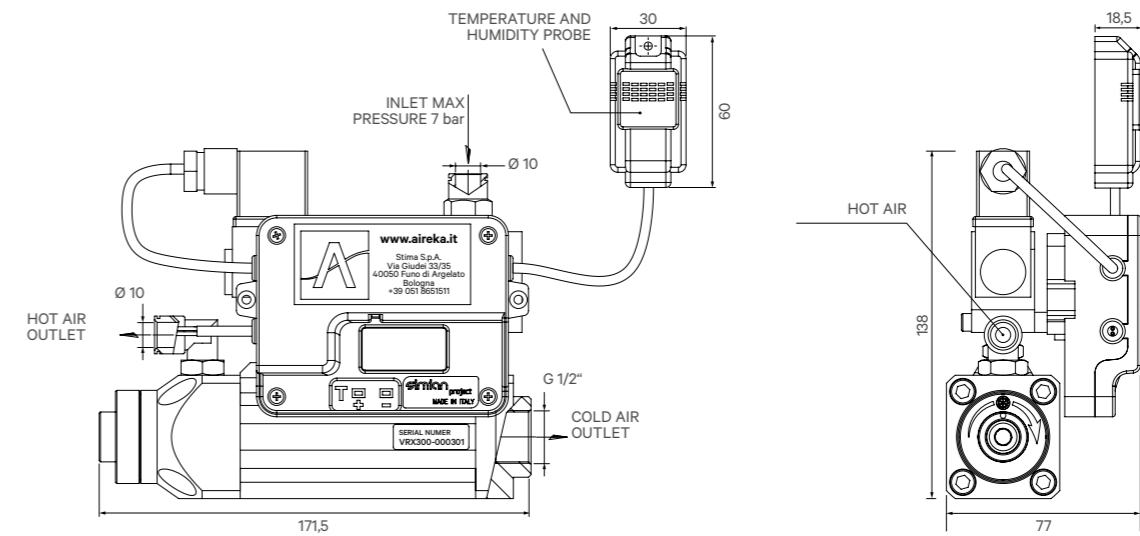

STAND-ALONE SERIES VR-400U-XTRONIC

ELECTRONICALLY-CONTROLLED PNEUMATIC COOLERS



GENERAL FEATURES - VR-400U XTRONIC

Power supply	24 V DC
Recommended hose	Ø 8x1
Supply pressure	max 7 bar
Cooling power and performances	See VR-400U (page 16)
Probe length	1 m
Temperature range	-20°C +60°C
Humidity range	00% 100% RH
Accuracy	0.1°C , 0.1 % RH
Current capacity	max 10 A
Coil voltage and power	24 V - 3.1 W
Electric wires' section	0.75 mm
Weight	845 g

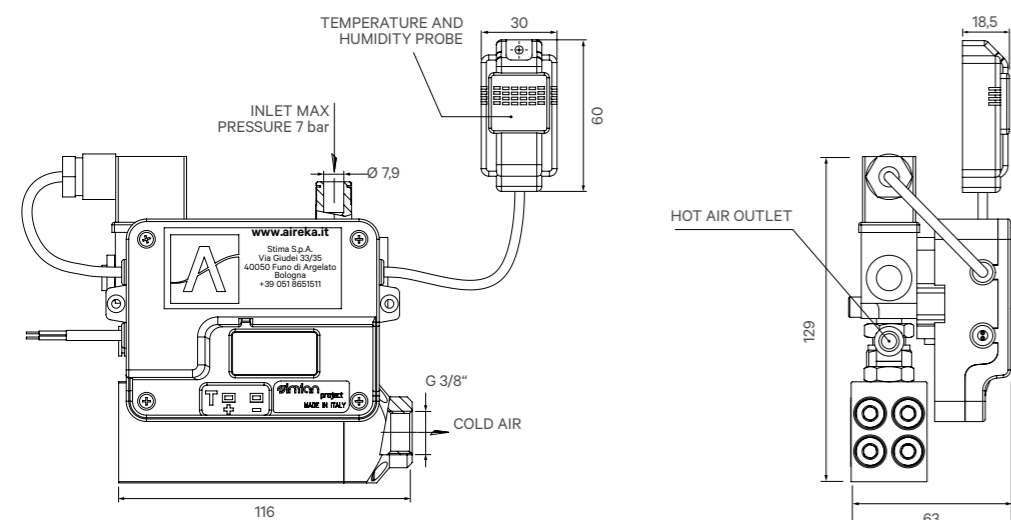

STAND-ALONE SERIES VRX-500 XTRONIC

ELECTRONICALLY-CONTROLLED PNEUMATIC COOLERS



GENERAL FEATURES - VRX-500 XTRONIC

Supply voltage	24 V DC
Recommended hose	Ø 10x1
Supply pressure	max 7 bar
Cooling power and performances	See VR-400U (pag. 23)
Probe length	1 mt
Temperature range	-20°C +60°C
Humidity range	00% 100% RH
Accuracy	0.1°C , 0.1 % RH
Current capacity	max 10 A
Coil voltage and power	24 V - 3.1 W
Electric wires' section	0.75 mm
Weight	1430 g

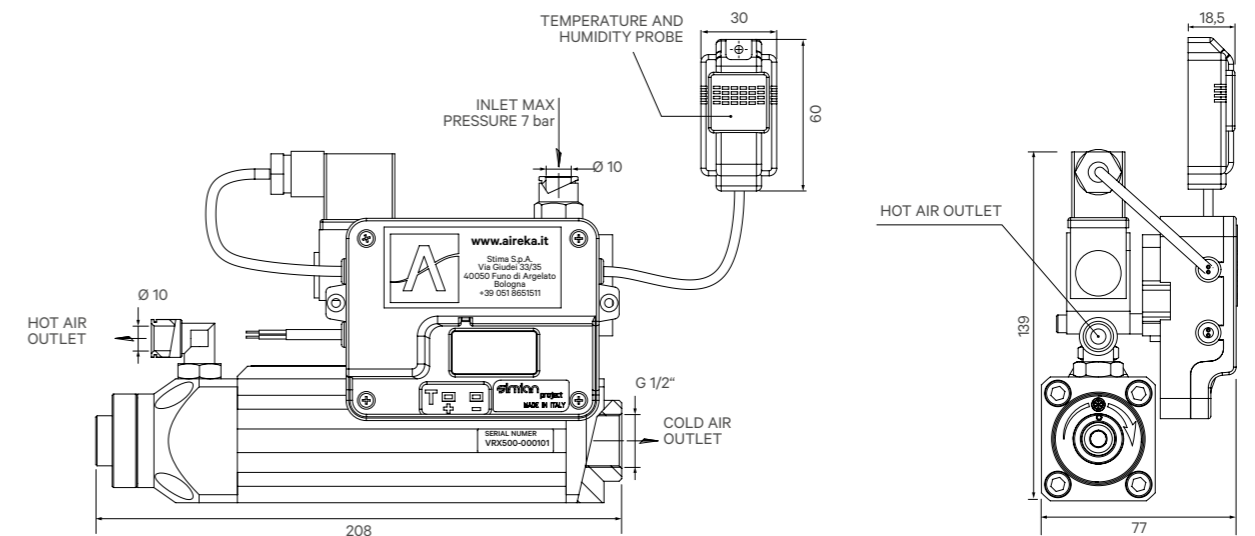

STAND-ALONE SERIES VRX-1000-XTRONIC

ELECTRONICALLY-CONTROLLED PNEUMATIC COOLERS

SPECIAL APPLICATIONS



GENERAL FEATURES - VRX-1000 XTRONIC

Power supply	24 V DC
Recommended hose	Ø 12x1
Supply pressure	Max 7 bar
Cooling power and performances	Vedi VRX-1000 (pag. 24)
Probe length	1 m
Temperature range	-20°C +60°C
Humidity range	00% 100% RH
Accuracy	0.1°C , 0.1 % RH
Current capacity	max 10 A
Coil voltage and power	24 V - 3.1 W
Electric wires' section	0.75 mm
Weight	1630 g

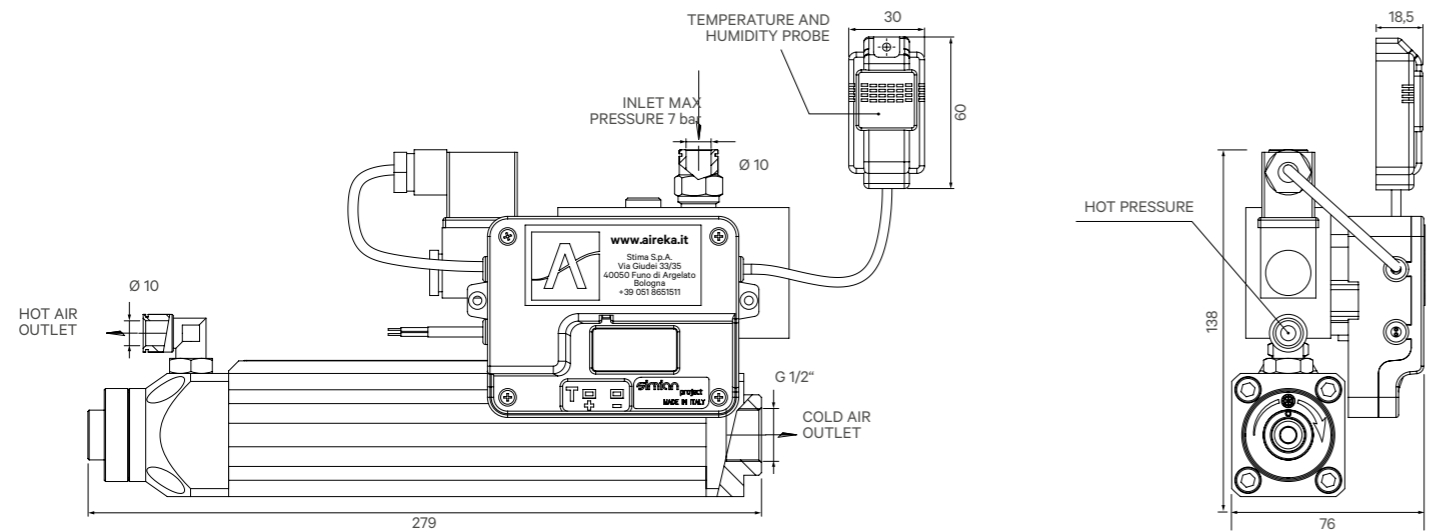

VRX300 + KDA
HEATER VERSION



VRX500 MOTION
COOLER WITH ADJUSTMENT CONTROLLABLE BY PLC



VRX300 + KDA
WITH DISTRIBUTOR OF COLD AIR



RING-COOLING SYSTEM



KDA
COLD AIR DISTRIBUTOR
ALL LENGTHS AVAILABLE ON REQUEST

COOLER AIR SAVING

PATENTED SYSTEM



The best practice in cooling down enclosures involves also a correct distribution of the cold air, after it has been produced.

To make it possible, we supply air-blowing modules, connection fittings in technopolymer, and tubes with double insulation. All this to have zero losses of cold energy and to get the highest effectiveness in your application.

All these accessories are customisable, to meet your specific demands.



Filter against impurities, for the fixation of the hot air extractor



Fittings for cold air distribution



Customisable air-blowing module



Single air-blowing module

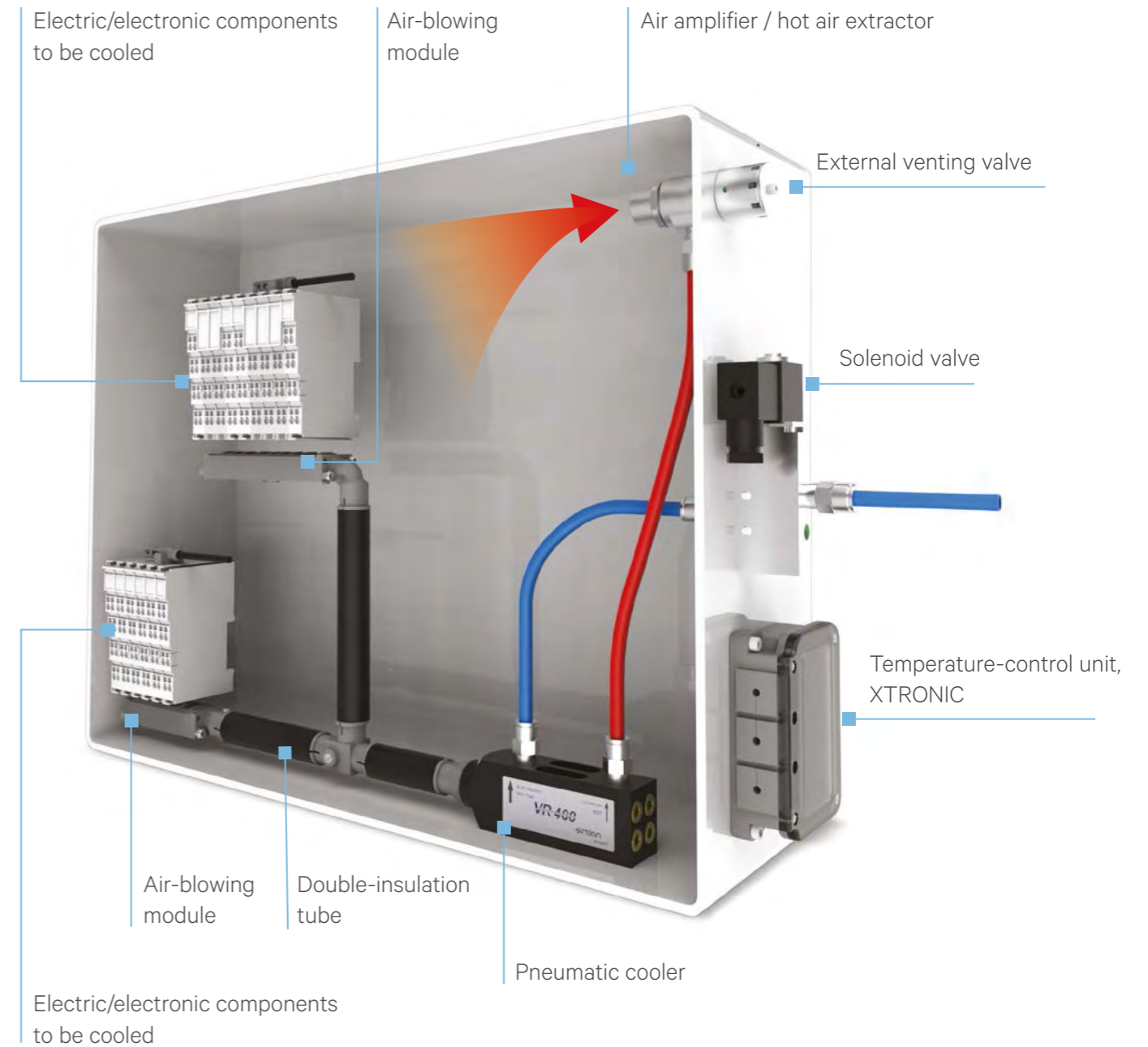

COOLER AIR SAVING

PATENTED SYSTEM



VR Series coolers and **AM Series** amplifiers used together to introduce cold air and extract hot air from electrical cabinets at the same time, using a single compressed air supply.

- Effective ventilation of the electrical cabinet
- Reduction of compressed air consumption
- Optimisation of cooling results

No matter how much cold air is introduced into an electrical cabinet, the effectiveness and efficiency of cooling will never be optimal unless the hot air generated by the electrical components is properly ventilated at the same time. With ventilation we mean both the creation of convection flows inside the cabinet which effectively distribute the air around the components, and the actual extraction of hot air from the cabinet itself.

By using the Cooler Air Saving patented system by Simian Project, two results are obtained: the first, using the VR Series coolers, is the prompt and precise cooling of the components that heat the cabinet the most. This thanks to the flexibility of installation (brackets and magnets) and the fact that the flow of cold air can be precisely directed on the main heat sources (by using adjustable nozzles). The second result is the proper ventilation of the electrical cabinet, thanks to the extraction power generated by the AM Series air amplifier, which is actuated by the hot air exhausted from the cooler.

The picture shows the system set up inside an electrical cabinet:

The VRX-500 cooler (fig.1) is actuated with compressed air from outside; the flow of cold air is directed, by using adjustable nozzles, on the electrical components that give off the most heat, while the exhaust of hot air is channelled by the red hose (fig. 3) to actuate the AM Series amplifier

The amplifier (fig.2) is mounted on the top right-hand side of the electrical cabinet; the pass-through installation allows it to suction and extract air from the cabinet; in the example of the picture, its position in the upper part of the cabinet ensures that the extraction occurs where most of the hot air accumulates and that even the electrical components located on the opposite side of the source of cold air remain at a temperature suitable for optimal functioning.

Even where pass-through mounting is not possible (for example in the event of installations in cabinets where IP protection must be guaranteed), the

fitting of the amplifier inside the cabinet ensures forced recycling of air, which eliminates the concentration of hot air in the areas located furthest away from sources of cold air.

The patented system also works well together with industrial air-conditioners in electrical cabinets with the following characteristics:

- Large electrical cabinets where the cold air generated by the air-conditioner has trouble in reaching all parts of the cabinet;
- Electrical cabinets with electrical components laid out in such a way that the convection of air around the components is tricky;
- Electrical cabinets where the heat is generated by a few components that are located far from the area where the air-conditioner introduces the cold air.

N.B.: The Cooler Air Saving system works with VRX-300, VRX-500, and VRX-1000 coolers together with AM-20ES and AM-40ES amplifiers.

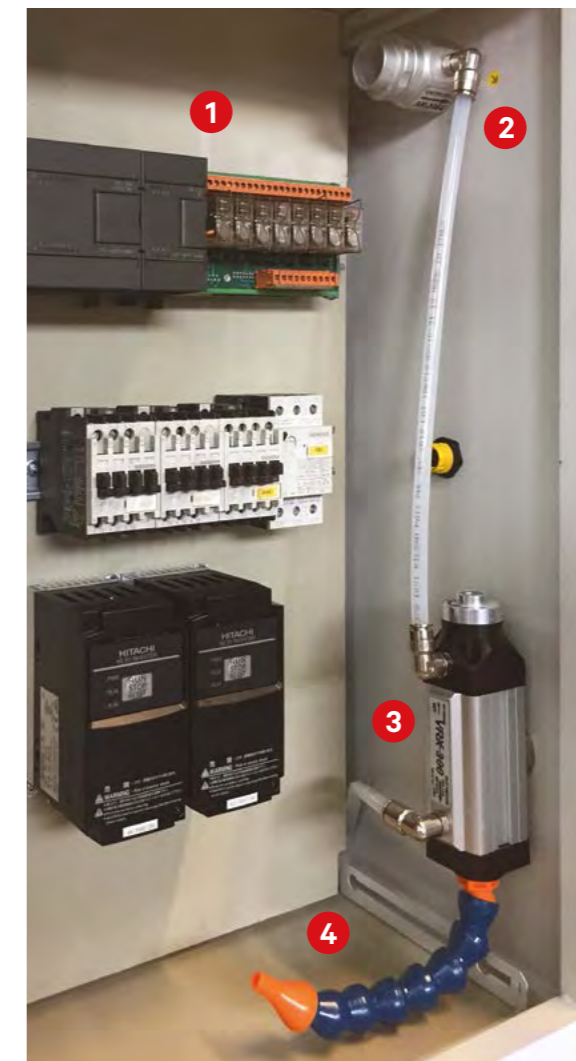



Description of the set-up and instrumentation used for our tests on air knives.

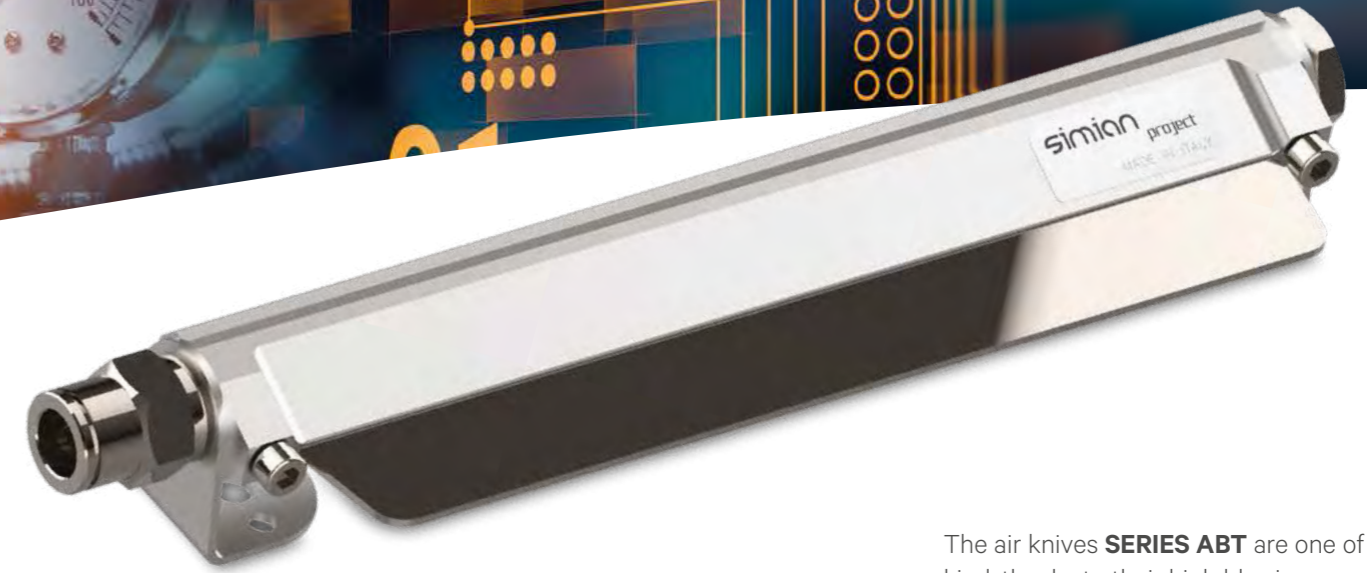
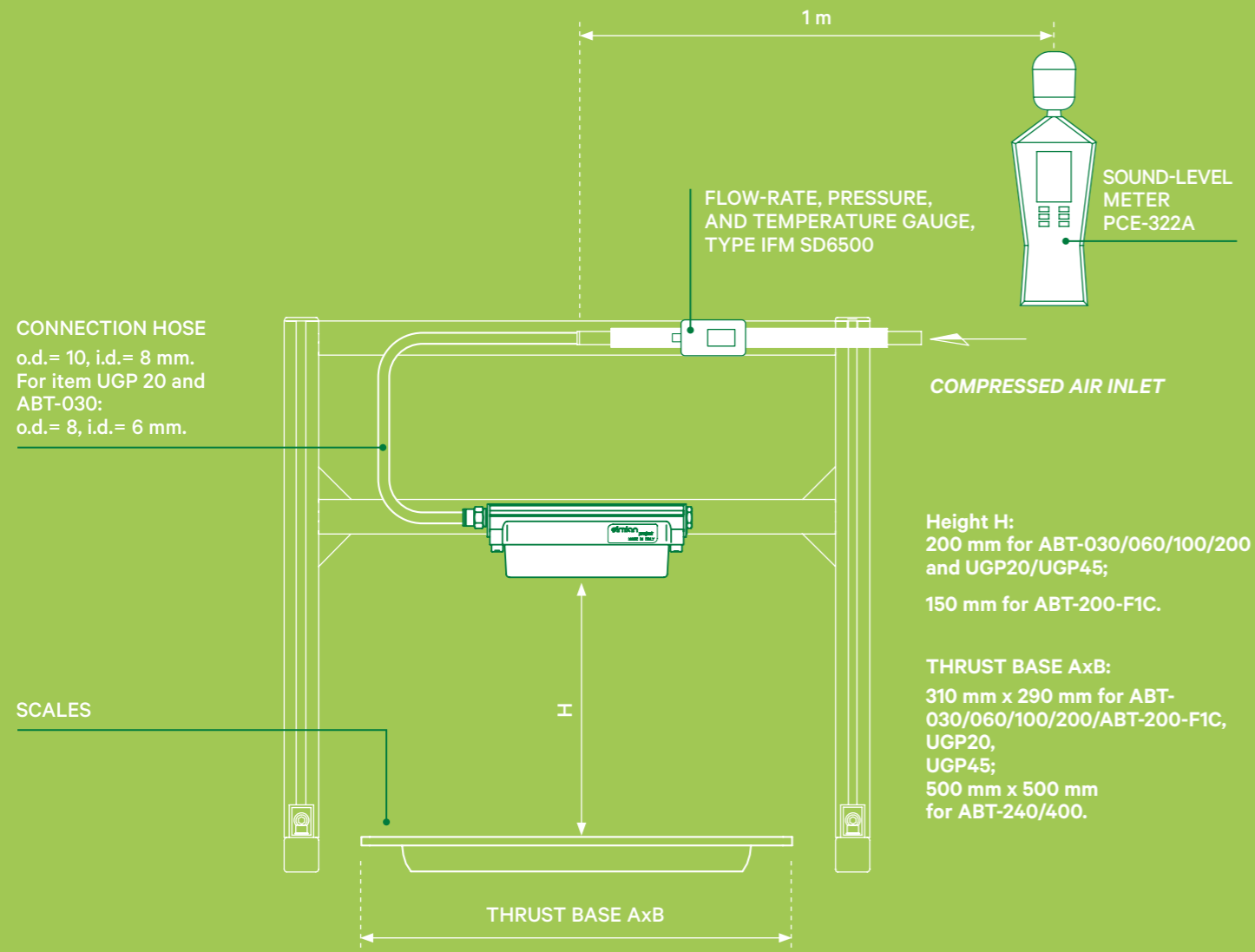

The air knives **SERIES ABT** are one of a kind, thanks to their high blowing power, which is a result of the air flow on both sides of the blade, and thanks to their easy installation, by means of two neodymium magnets and of brackets, which make it possible to direct the knife according to all demands. These products are very effective for cleaning, drying, and cooling.

- Design geometries optimised to maximise the Coanda effect
- Double blow-off flow (both sides of the blade)
- Powerful, uniform flow, suitable for cleaning small and large surfaces
- Modular design and possibility of customisation
- No moving parts, so maintenance-free

DESCRIPTION OF THE COANDA EFFECT

The air amplifiers and the air knives exploit the Coanda effect.

This phenomenon can be explained as the tendency of a fluid to follow the contour of a surface nearby. It is named after the pioneer of aerodynamics Henri Coanda, who in 1936 patented some instruments that exploited the capacity to deviate a flow.

The compressed air introduced in an amplifier or in an air knife is forced to pass through a reduced section, from 0.02 mm to 0.08 mm, and, by lapping the surface nearby, the surrounding air is attracted towards the flow's direction, so that the volume of air becomes from 5 to 20 times bigger than it was at the inlet.

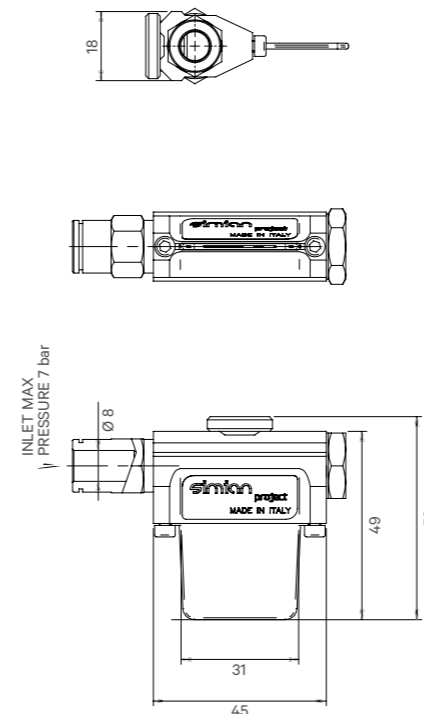
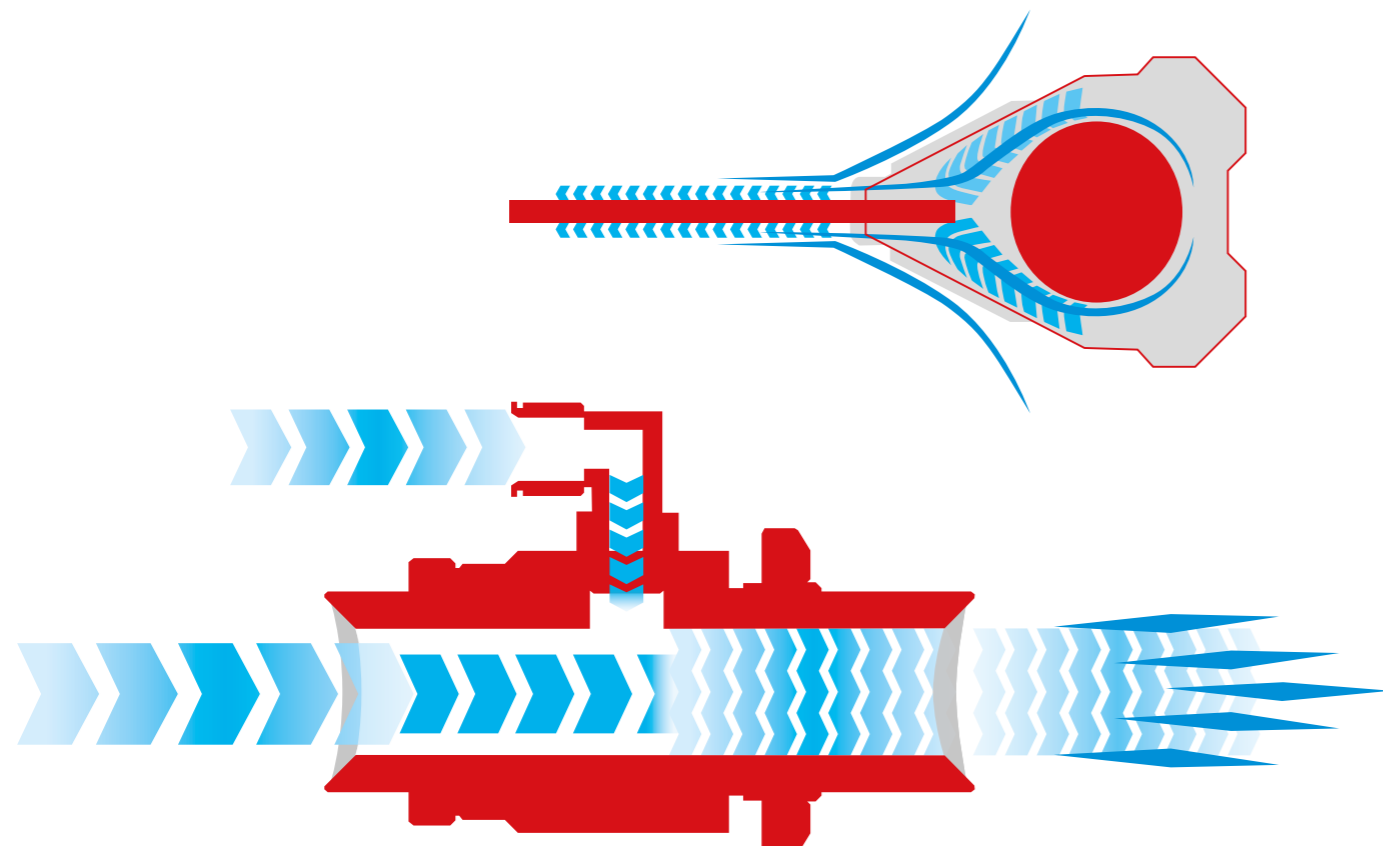

GENERAL FEATURES - ABT-030

Materials	Anodized aluminium and AISI304 s.s.
Air supply port	Fitting Ø-8
Fixation	Optional angular bracket
Blade length	32 mm
Air supply pressure	1-7 bar
Optional magnetic support	KACM-ABT030
Weight	110 g

PERFORMANCES AND CONSUMPTION TABLE

Pressure bar	Consumption NI/min	Thrust a 200 mm in g	Noise level dBA
1	150	97	70
2	255	213	76
3	346	330	79
4	433	450	82
5	516	590	84
6	599	720	85
7	666	850	86

SERIES ABT-030 PLUS

DOUBLE-SLOT AIR KNIVES

SERIES ABT-060

DOUBLE-SLOT AIR KNIVES



GENERAL FEATURES - ABT-030 PLUS

Materials	Anodized aluminium and AISI304 s.s.
Air supply port	Fitting Ø-10
Fixation	Optional angular bracket
Blade length	32 mm
Air supply pressure	1-7 bar
Optional magnetic support	KACM-ABT030
Weight	130 g

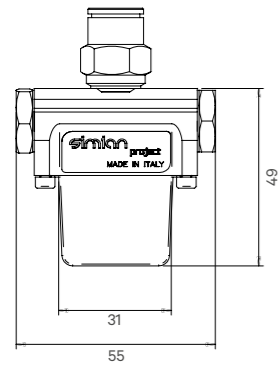
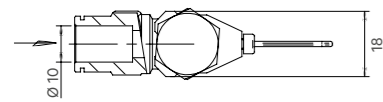

PERFORMANCES AND CONSUMPTION TABLE

Pressure bar	Consumption NI/min	Thrust a 200 mm in g	Noise level dBA
1	166	120	70
2	266	230	76
3	366	360	78
4	458	500	81
5	549	640	82,5
6	633	780	84
7	716	940	86

GENERAL FEATURES - ABT-060

Materials	Anodized aluminium and AISI304 s.s.
Air supply port	Fitting Ø-10
Fixation	Optional angular bracket
Blade length	76 mm
Air supply pressure	1-7 bar
Optional magnetic support	KACM-ABT030
Weight	170 g

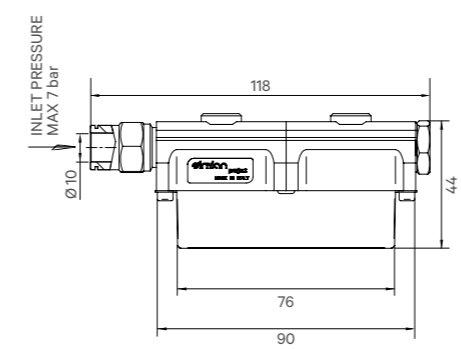
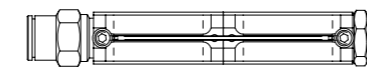

PERFORMANCES AND CONSUMPTION TABLE

Pressure bar	Consumption NI/min	Thrust a 200 mm in g	Noise level dBA
1	283	170	72
2	449	340	77
3	629	570	80
4	816	810	83
5	982	1090	85
6	1166	1400	86
7	1350	1700	87

SERIES ABT-100

DOUBLE-SLOT AIR KNIVES

SERIES ABT-200

DOUBLE-SLOT AIR KNIVES



GENERAL FEATURES - ABT-100

Materials	Anodized aluminium and AISI304 s.s.
Air supply port	Fitting Ø-10
Fixation	Integrated feet
Blade length	100 mm
Air supply pressure	1-7 bar
Optional magnetic support	KACM-ABT100
Weight	200 g

GENERAL FEATURES - ABT-200

Materials	Anodized aluminium and AISI304 s.s.
Air supply port	Fitting Ø-10
Fixation	Integrated feet
Blade length	170 mm
Air supply pressure	1-7 bar
Optional magnetic support	KACM-ABT200
Weight	290 g

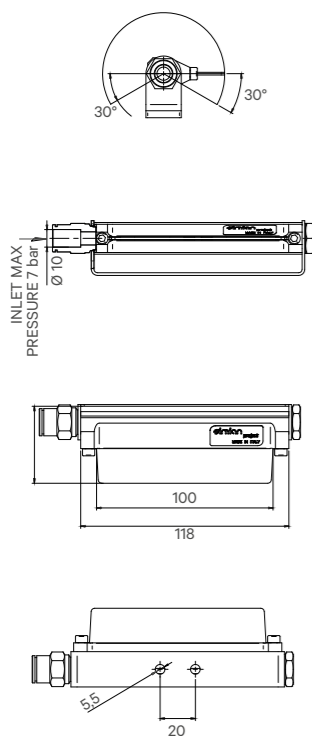

PERFORMANCES AND CONSUMPTION TABLE

Pressure bar	Consumption NI/min	Thrust a 200 mm in g	Noise level dBA
1	366	216	75
2	558	450	79
3	724	690	82
4	899	930	84
5	1082	1210	85
6	1233	1530	87
7	1410	1800	88

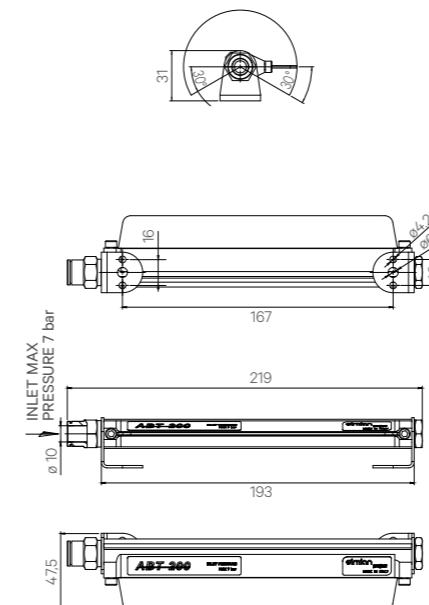

PERFORMANCES AND CONSUMPTION TABLE

Pressure bar	Consumption NI/min	Thrust a 200 mm in g	Noise level dBA
1	499	245	75
2	940	570	80
3	1582	1030	84
4	2082	1450	87
5	2665	2000	90
6	3248	2400	93

SERIES ABT-240

DOUBLE-SLOT AIR KNIVES

SERIES ABT-400

DOUBLE-SLOT AIR KNIVES



GENERAL FEATURES - ABT-240

Materials	Anodized aluminium and AISI304 s.s.
Air supply port	Fitting Ø 10
Fixation	Integrated feet
Flow width	218 mm
Supply pressure	1-7 bar
Optional magnetic support	KACM-ABT100
Weight	300 g

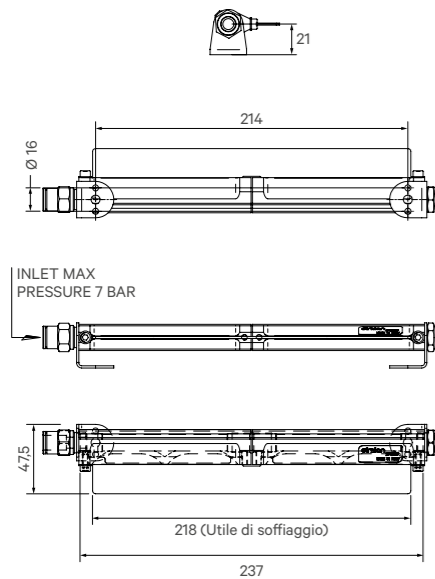

PERFORMANCES AND CONSUMPTION TABLE

Pressure bar	Consumption NI/min	Thrust a 200 mm in g	Noise level dBA
1	283	190	72
2	449	350	77
3	629	515	80
4	816	730	83
5	982	990	85
6	1166	1260	86

GENERAL FEATURES - ABT-400

Materials	Anodized aluminium and AISI304 s.s.
Air supply port	Fitting Ø 10
Fixation	Integrated feet
Flow width	362 mm
Supply pressure	7 bar
Optional magnetic support	KACM-ABT200
Weight	450 g

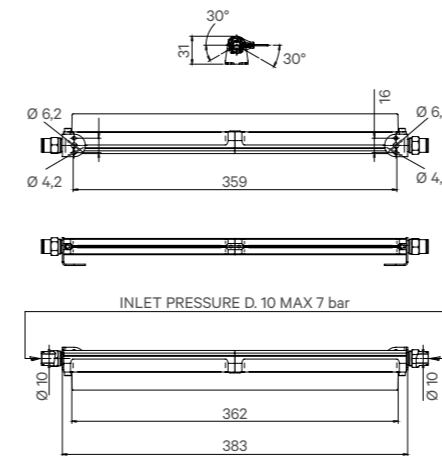

PERFORMANCES AND CONSUMPTION TABLE

Pressure bar	Consumption NI/min
1	1530
2	1956
3	2720
4	3146
5	3910
6	4760
7	5326

SERIES ABT-600

DOUBLE-SLOT AIR KNIVES



GENERAL FEATURES - ABT-600	
Materials	Anodized aluminium and AISI304 s.s.
Air supply port	Fitting Ø 10
Fixation	Integrated feet
Flow width	554 mm
Supply pressure	max 7 bar
Optional magnetic support	KACM-ABT200
Weight	690 g

PERFORMANCES AND CONSUMPTION TABLE

Pressure bar	Consumption NI/min
1	2295
2	2934
3	4080
4	4719
5	5865
6	7140
7	7989

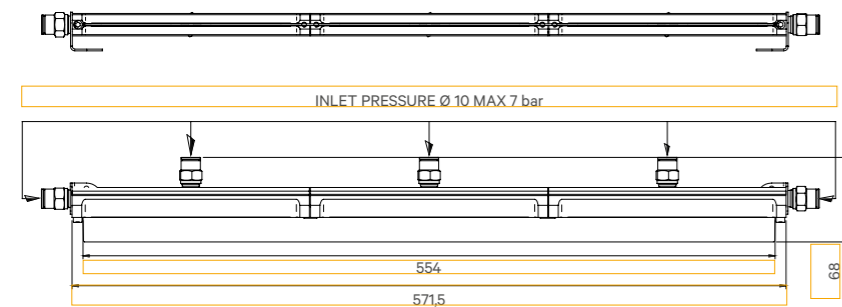
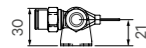

SERIES ABT-800

DOUBLE-SLOT AIR KNIVES



GENERAL FEATURES - ABT-800	
Materials	Anodized aluminium and AISI304 s.s.
Air supply port	Fitting Ø 10
Fixation	Integrated feet
Flow width	745 mm
Supply pressure	max 7 bar
Optional magnetic support	KACM-ABT200
Weight	900 g

PERFORMANCES AND CONSUMPTION TABLE

Pressure bar	Consumption NI/min
1	2295
2	2934
3	4080
4	4719
5	5865
6	7140
7	7989

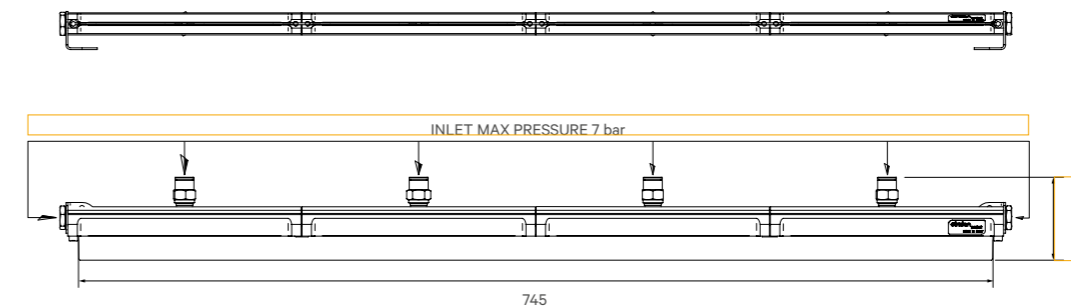

ACCESSORIES AND SPECIAL VERSIONS

AIR KNIVES

SERIES ABT-F1C

CALIBRATED SINGLE-SLOT AIR KNIVES



ABT 200
WITH CONCAVE AND CONVEX LIP



ABT 030 PLUS
WITH SHAPED LIP



ABT 030 PLUS
WITH TUBE FOR CONNECTION
TO MACHINE TOOL



ABT 030 PLUS
WITH CURVED LIP



GENERAL FEATURES - ABT-F1C

Materials	Aluminium and Delrin
Air supply port	Fitting Ø 10
Fixation	Integrated feet
Flow width	From 150 mm to 1200 mm
Supply pressure	max 7 bar
Noise level for every 200 mm length	Range from 62 to 82 dBA
Optional magnetic kit	KACM-ABT200

PERFORMANCE AND CONSUMPTION TABLE (For length 100 mm)

Pressure bar	Consumption NI/min	Thrust force at 150 mm, in g
1	109	61
2	195	135
3	279	220
4	341	310
5	416	400
6	483	520
7	566	635

MAGNETIC SUPPORT	
PART-NUMBER	AIR KNIFE
KACM-ABT030	ABT-030 / ABT-060
KACM-ABT100	ABT-100
KACM-ABT200	ABT-200 / ABT-240 / ABT-400 / ABT-600 / ABT-800

FIXATION BRACKET	
PART-NUMBER	AIR KNIFE
ABT-05	ABT-030 / ABT-060

CUSTOMISED VERSIONS
On request we can supply versions customised in shape and/or material.

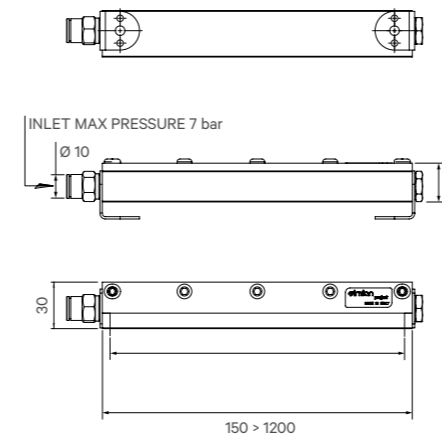
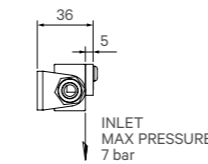

SERIES ABX-1000

LONG AIR KNIVES SUPPLIED BY AIR AMPLIFIER



GENERAL FEATURES - ABX-1000

Materials	Anodised aluminium / Stainless steel
Fixation	On request
Flow width	1000 mm
Supply pressure	Based on the type of air supply

On request: supply connection at 90°.

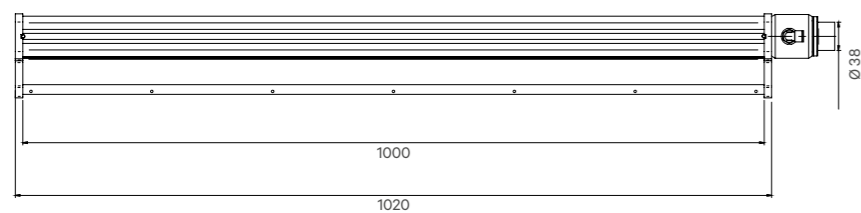
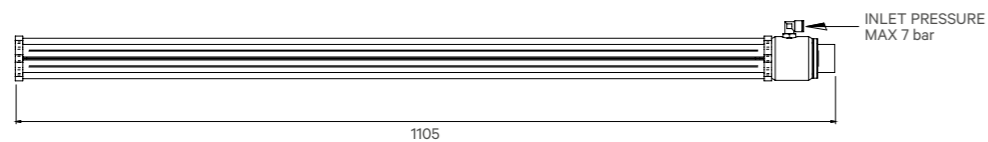
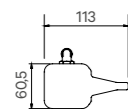

SERIES ABX-1500

LONG AIR KNIVES SUPPLIED BY AIR AMPLIFIER



GENERAL FEATURES - ABX-1500

Materials	Anodised aluminium / Stainless steel
Fixation	On request
Flow width	1500 mm
Supply pressure	Based on the type of air supply

On request: supply connection at 90°.

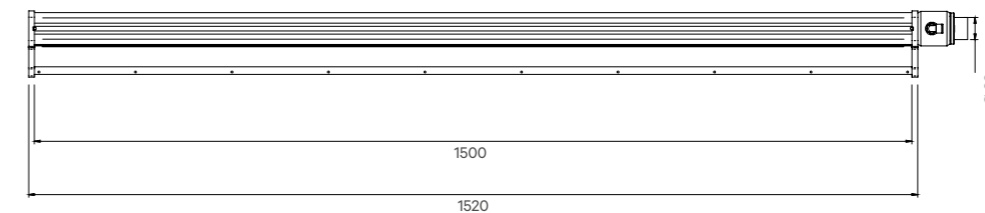
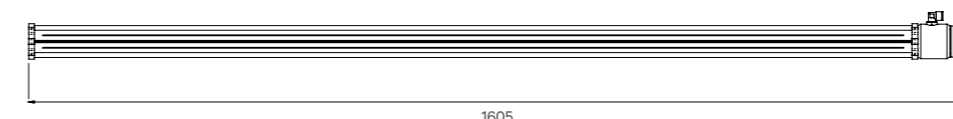
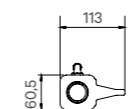

SERIES ABX-2000

LONG AIR KNIVES SUPPLIED BY AIR AMPLIFIER



GENERAL FEATURES - ABX-2000

Materials	Anodised aluminium / Stainless steel
Fixation	On request
Flow width	2000 mm
Supply pressure	Based on the type of air supply

On request: supply connection at 90°.

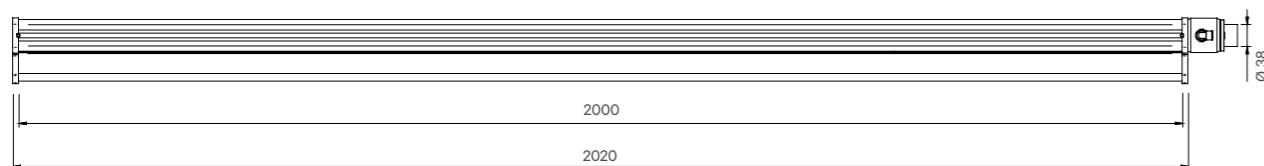
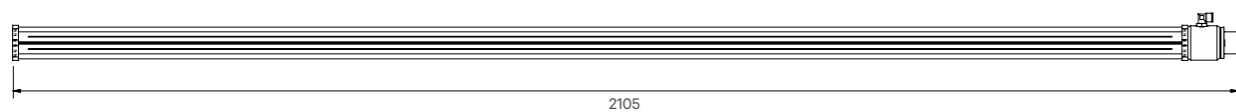
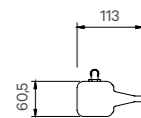

SERIES ABZ-1000

LONG AIR KNIVES TO BE SUPPLIED BY ELECTRIC BLOWER



GENERAL FEATURES - ABZ-1000

Materials	Zinc-plated metal sheet
Fixation	On request
Flow width	1000 mm
Supply pressure	Based on the type of air supply

On request: supply connection at 90°.

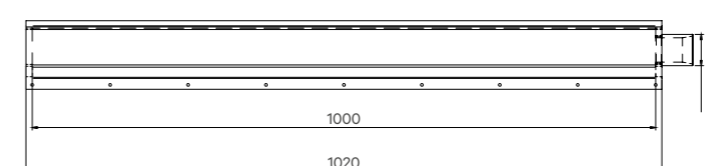
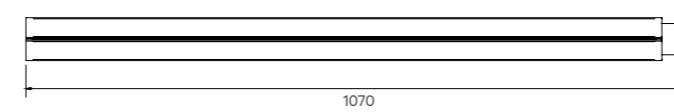
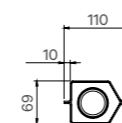

SERIES ABZ-1500

LONG AIR KNIVES TO BE SUPPLIED BY ELECTRIC BLOWER



GENERAL FEATURES - ABZ-1500

Materials	Zinc-plated metal sheet
Fixation	On request
Flow width	1500 mm
Supply pressure	Based on the type of air supply

On request: heated air flow.

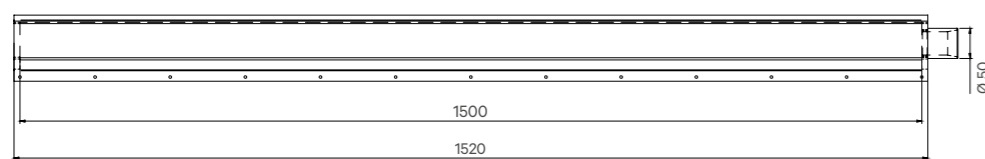
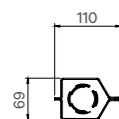

SERIES ABZ-2000

LONG AIR KNIVES TO BE SUPPLIED BY ELECTRIC BLOWER



GENERAL FEATURES - ABZ-2000

Materials	Zinc-plated metal sheet
Fixation	On request
Flow width	2000 mm
Supply pressure	Based on the type of air supply

On request: heated air flow.

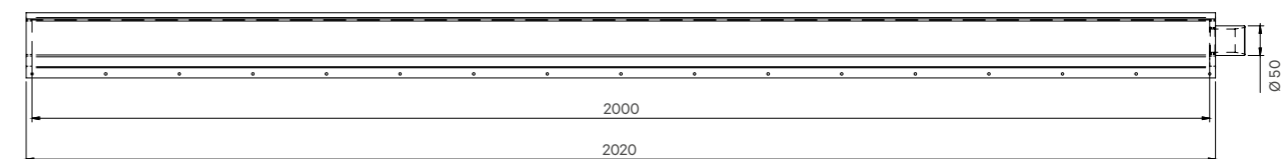
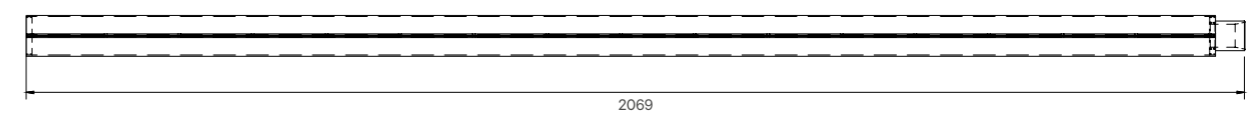
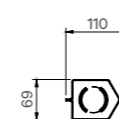

Description of the set-up and instrumentation used for our tests on air amplifiers.

CONNECTION HOSE

FOR ITEMS AM-10T/AM-15T
o.d. = 8, i.d. = 6 mm.

FOR ITEMS AM-20T/AM-25T/AM-30T:
o.d. = 10, i.d. = 8 mm.

FOR AM-40T/AM-50T:
o.d. = 12, i.d. = 10 mm.

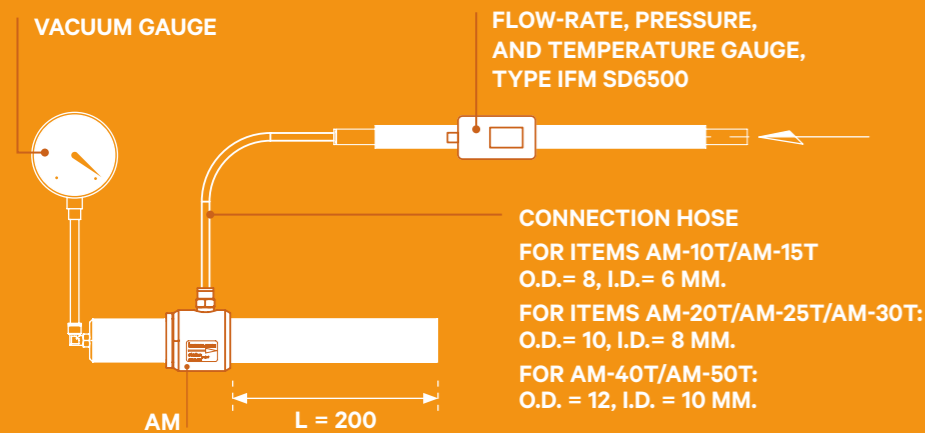
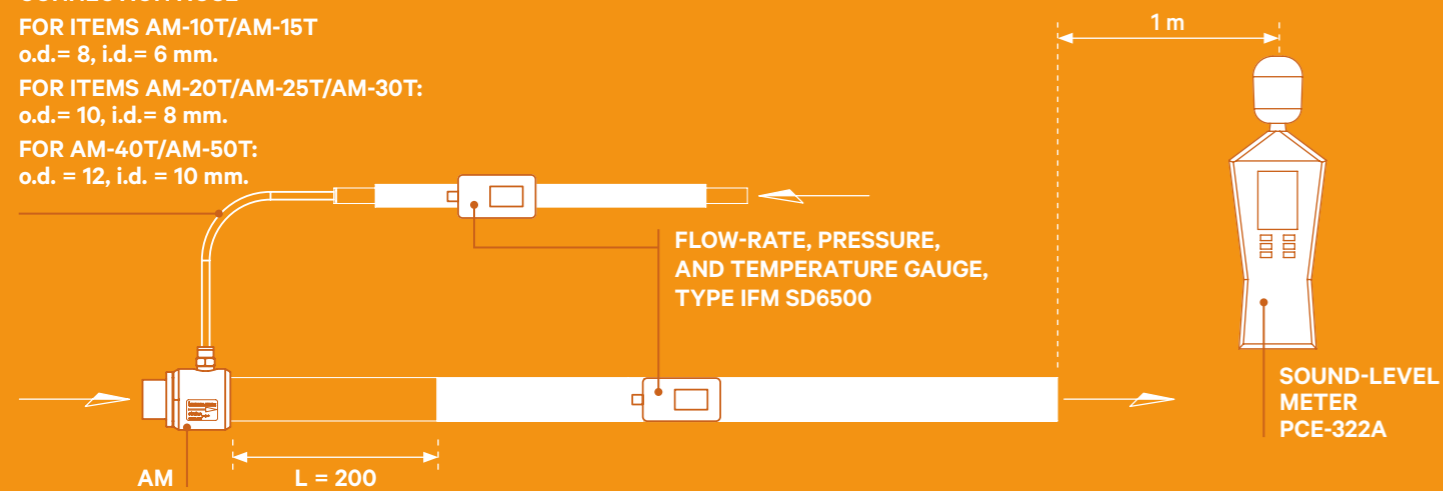

The **AM-T Series** air amplifiers offer excellent performance for both suction and blow-off. The quality of design and construction optimises the Coanda effect, so they use a small amount of compressed air to generate a powerful, high-speed flow. Their capability to perform both functions of suction and blow-off make them useful for many applications, including ventilating electric cabinets, conveying fumes and lightweight particles produced by machining, conveying and handling of light parts, drying, and cooling. When combined with the VR Series coolers, they create an effective patented system where, by conveying the hot air flow exhausted by the cooler to actuate an AM Series amplifier, the cooling power is optimised, so that to make it possible to draw hot air out of enclosures and ventilate closed areas to be cooled. The flow-rate can be adjusted by simply turning the nut.

- Design geometries optimised to maximise the Coanda effect
- Adjustable flow-rate
- Wide section for suction and blow-off, suitable for a variety of applications
- Instant operation
- No moving part, so not subject to wear and tear
- No electricity or chemical substances required
- More efficient than venturis and ejectors
- It does not cause neither sparks nor interferences
- Reliable and maintenance-free

SERIES AM-10T

AIR AMPLIFIERS

SERIES AM-15T

AIR AMPLIFIERS

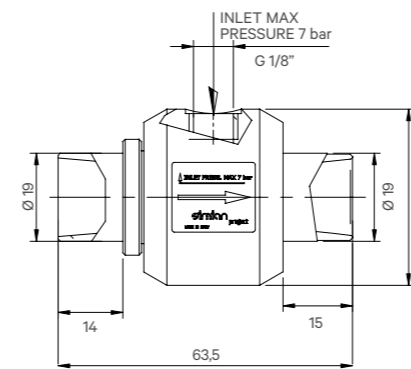
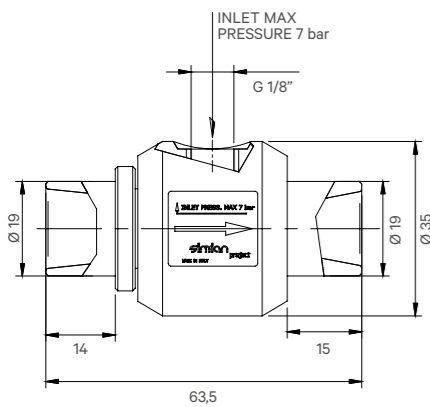
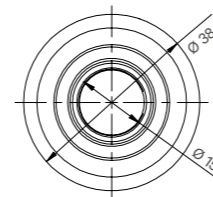
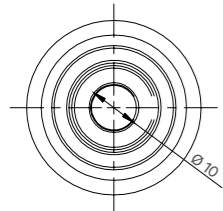
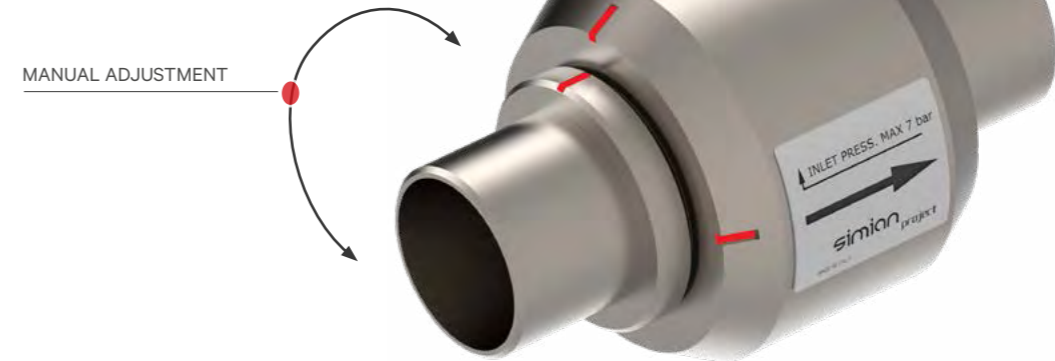
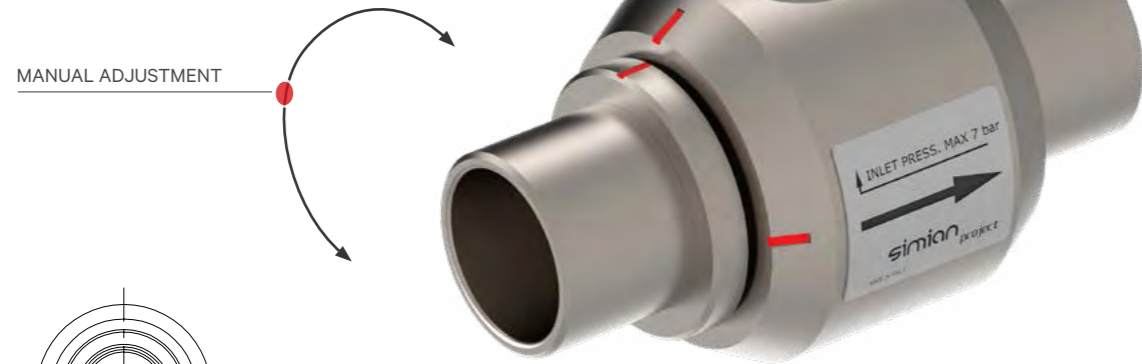

GENERAL FEATURES - AM-10T	
Materials	Aluminium
Air inlet port	G-1/8" F
Inlet diameter	Ø 19
Outlet diameter	Ø 19
Air supply pressure	max 7 bar
Recommended hose	Ø 6x1 - Ø 8x1
Weight	95 g

GENERAL FEATURES - AM-15T	
Materials	Aluminium
Air inlet port	G-1/8" F
Inlet diameter	Ø 19
Outlet diameter	Ø 19
Air supply pressure	max 7 bar
Recommended hose	Ø 8x1 - Ø 10x1
Weight	100 g

PERFORMANCES AND CONSUMPTION TABLE

OPENING 90°					
SUPPLY PRESSURE bar	CONSUMPTION NI/min	FLOW-RATE NI/min	AMPLIFICATION RATIO	VACUUM mbar	NOISE LEVEL dBA
2	76	349,9	4,6	65	63
3	101	449,8	4,4	100	65
4	126	506,4	4,0	130	66
5	153	558,1	3,6	155	68
6	178	621,4	3,5	185	70
OPENING 180°					
2	158	533,12	3,4	100	76
3	216	643	3,0	155	80
4	283	741,4	2,6	190	85
5	341	816,34	2,4	220	90
6	391	849,6	2,2	240	92

PERFORMANCES AND CONSUMPTION TABLE

OPENING 90°					
SUPPLY PRESSURE bar	CONSUMPTION NI/min	FLOW-RATE NI/min	AMPLIFICATION RATIO	VACUUM mbar	NOISE LEVEL dBA
2	100	899,6	9,0	30	70
3	133	1132,9	8,5	45	74
4	168	1332,8	7,9	60	76
5	204	1516	7,4	75	78
6	244	1649,3	6,8	90	79
OPENING 180°					
2	225	1366	6,1	60	80
3	299	1666	5,6	95	84
4	373	1949,2	5,2	130	88
5	443	2165,8	4,9	160	89
6	509	2265,8	4,4	180	90

SERIES AM-20T

AIR AMPLIFIERS

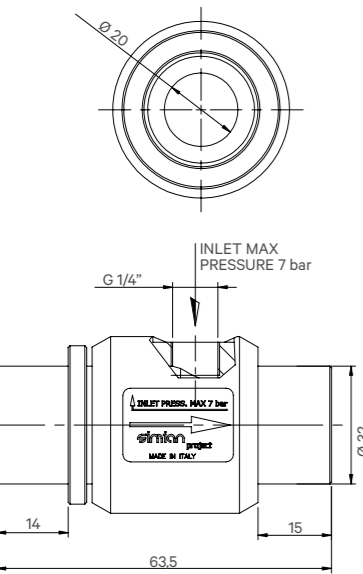

GENERAL FEATURES - AM-20T

Materials	Aluminium
Air inlet port	G-1/4" F
Inlet diameter	Ø 32
Outlet diameter	Ø 32
Air supply pressure	max 7 bar
Recommended hose	Ø 8x1 - Ø 10x1
Weight	240 g

PERFORMANCES AND CONSUMPTION TABLE

OPENING 90°					
SUPPLY PRESSURE bar	CONSUMPTION NI/min	FLOW-RATE NI/min	AMPLIFICATION RATIO	VACUUM mbar	NOISE LEVEL dBA
2	186	1499,4	8,0	10	68
3	266	1832,6	6,9	15	72
4	333	2199,1	6,6	22	74
5	391	2532,3	6,5	29	75
6	458	2798,9	6,1	35	77
OPENING 180°					
2	391	2132,5	5,4	20	75
3	519	2699	5,2	32	78
4	646	3115,4	4,8	45	80
5	771	3582	4,6	58	82
6	899	3965	4,4	70	85

SERIES AM-25T

AIR AMPLIFIERS

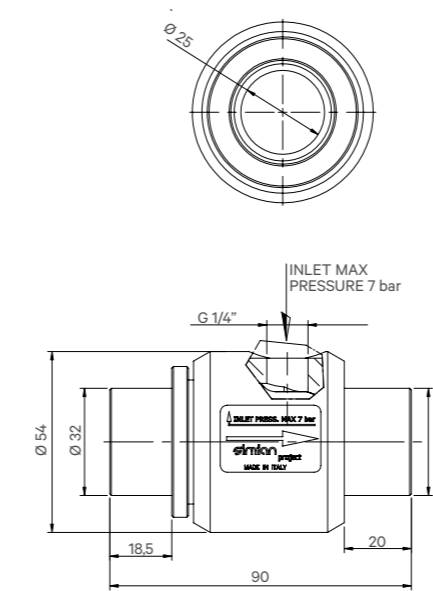
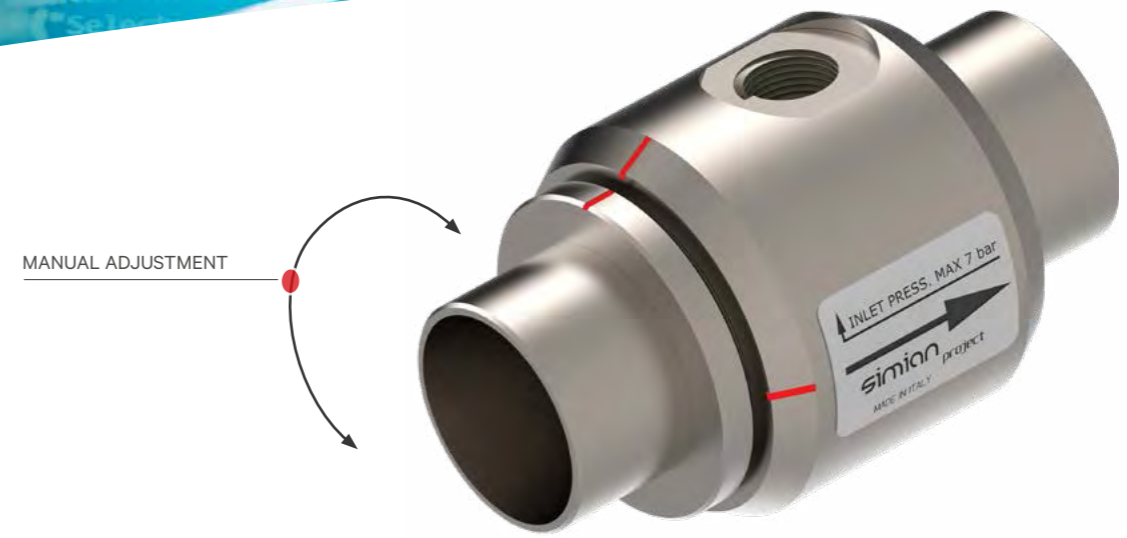

GENERAL FEATURES - AM-25T

Materials	Aluminium
Air inlet port	G-1/4
Inlet diameter	Ø 32
Outlet diameter	Ø 32
Air supply pressure	max 7 bar
Recommended hose	Ø 10x1 - Ø 12x1
Weight	280 g

PERFORMANCES AND CONSUMPTION TABLE

OPENING 90°					
SUPPLY PRESSURE bar	CONSUMPTION NI/min	FLOW-RATE NI/min	AMPLIFICATION RATIO	VACUUM mbar	NOISE LEVEL dBA
2	283	1549,4	5,5	15	74
3	366	1992,2	5,4	24	75
4	466	2364,7	5,1	32	77
5	583	2665,6	4,6	41	78
6	699	2998,8	4,3	50	80
OPENING 180°					
2	583	2582,3	4,4	35	78
3	850	3165,4	3,7	55	81
4	1100	3615,2	3,3	75	84
5	1350	4031,7	3,0	95	86
6	1649	4414,9	2,7	110	88

SERIES AM-30T

AIR AMPLIFIERS

SERIES AM-40T

AIR AMPLIFIERS



MANUAL ADJUSTMENT

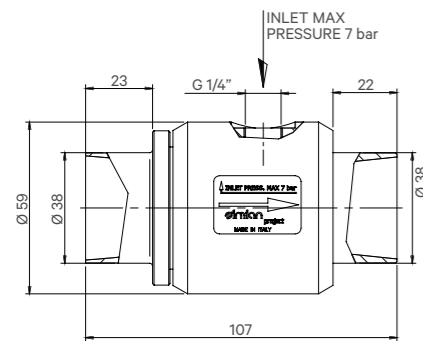
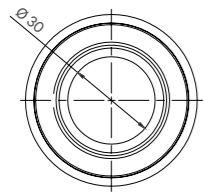
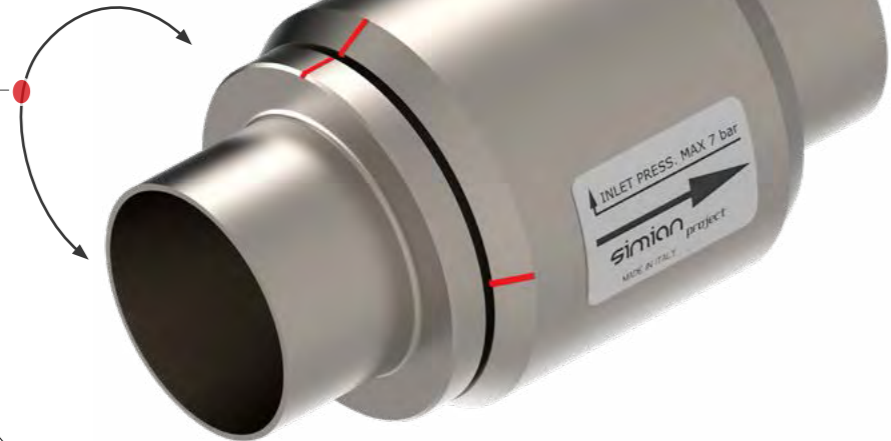

GENERAL FEATURES - AM-30T

Materials	Aluminium
Air inlet port	G-1/4
Inlet diameter	Ø 38
Outlet diameter	Ø 38
Air supply pressure	max 7 bar
Recommended hose	Ø 10x1 - Ø 12x1
Weight	380 g

MANUAL ADJUSTMENT

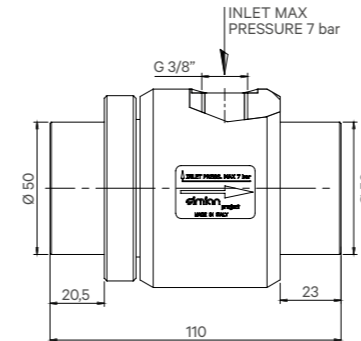
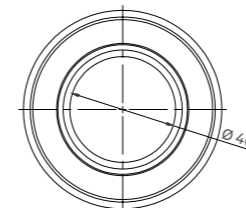
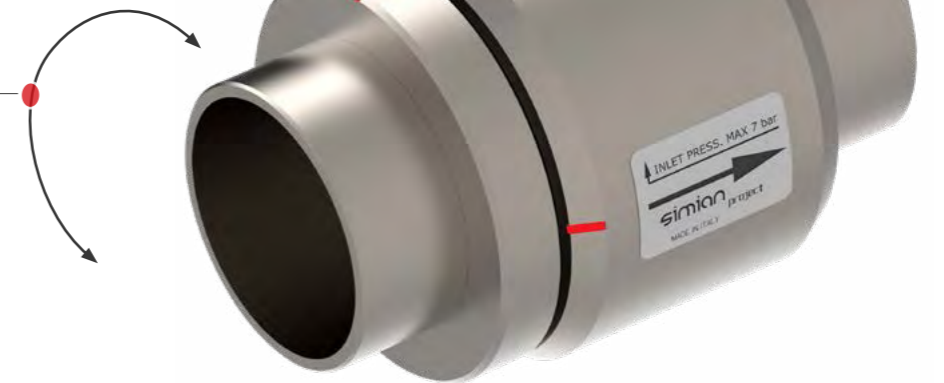

GENERAL FEATURES - AM-40T

Materials	Aluminium
Air inlet port	G-3/8
Inlet diameter	Ø 50
Outlet diameter	Ø 50
Air supply pressure	max 7 bar
Recommended hose	Ø 12x1 - Ø 14x1
Weight	600 g

PERFORMANCES AND CONSUMPTION TABLE

OPENING 90°					
SUPPLY PRESSURE bar	CONSUMPTION NI/min	FLOW-RATE NI/min	AMPLIFICATION RATIO	VACUUM mbar	NOISE LEVEL dBA
2	333	3415	10,2	15	80
3	483	4081,7	8,5	24	82
4	610	4581,5	7,5	32	84
5	730	4998	6,8	41	86
6	833	5497,8	6,6	50	88
OPENING 180°					
2	766	4165	5,4	40	84
3	1116	4998	4,5	52	88
4	1416	5664,4	4,0	65	91
5	1790	6414	3,6	80	93
6	2200	6830,6	3,1	100	94

PERFORMANCES AND CONSUMPTION TABLE

OPENING 90°					
SUPPLY PRESSURE bar	CONSUMPTION NI/min	FLOW-RATE NI/min	AMPLIFICATION RATIO	VACUUM mbar	NOISE LEVEL dBA
2	483	3332	6,9	12	80
3	660	4248	6,4	20	83
4	850	4998	5,9	25	85
5	1025	5831	5,7	30	87
6	1210	6297	5,2	35	89
OPENING 180°					
2	1082	4998	4,6	28	87
3	1566	5831	3,7	38	91
4	2082	6580	3,2	50	93
5	2600	7663	2,9	63	95
6	3048	8663	2,8	75	97

SERIES AM-50T

AIR AMPLIFIERS

ACCESSORIES

AIR AMPLIFIERS

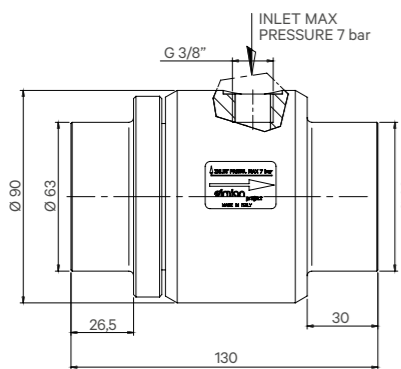
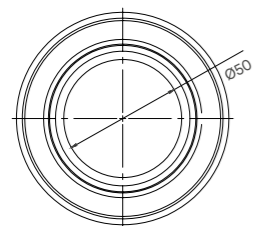
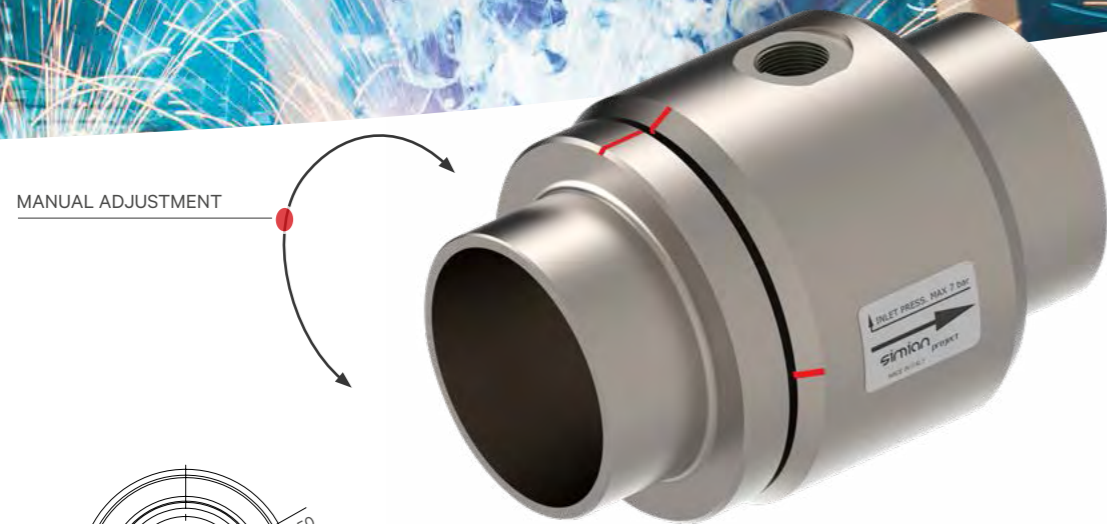

GENERAL FEATURES - AM-50T

Materials	Aluminium
Air inlet port	G-3/8
Inlet diameter	Ø 63
Outlet diameter	Ø 63
Air supply pressure	max 7 bar
Recommended hose	Ø 12x1 - Ø 14x1
Weight	950 g

PERFORMANCES AND CONSUMPTION TABLE

OPENING 90°					
SUPPLY PRESSURE bar	CONSUMPTION NI/min	FLOW-RATE NI/min	AMPLIFICATION RATIO	VACUUM mbar	NOISE LEVEL dBA
2	900	2700	3,0	0	-
3	1100	3300	3,0	0	-
4	1300	3800	2,9	0	-
5	1470	4250	2,9	0	-
6	1650	4700	2,8	25	-
APERTURA 180°					
2	1450	3700	2,6	0	-
3	1700	4500	2,6	19	-
4	1950	5300	2,7	36	-
5	2200	5900	2,7	55	-
6	2450	6500	2,7	75	-



STRAIGHT PUSH-IN FITTING FOR AIR SUPPLY

Part Number	Hose Ø	Thread	Air amplifier
S6510	6	1/8"	AM10-T
S6510	8	1/8"	AM10-T / AM15-T
S6510	10	1/8"	AM15-T
S6510	8	1/4"	AM20-T
S6510	10	1/4"	AM20-T / AM25-T / AM30-T
S6510	12	1/4"	AM25-T / AM30-T
S6510	12	3/8"	AM40-T / AM50-T
S6510	14	3/8"	AM40-T / AM50-T



ELBOW PUSH-IN FITTING FOR AIR SUPPLY

Part Number	Hose Ø	Thread	Air amplifier
S6520	6	1/8"	AM10-T
S6520	8	1/8"	AM10-T / AM15-T
S6520	10	1/8"	AM15-T
S6520	8	1/4"	AM20-T
S6520	10	1/4"	AM20-T / AM25-T / AM30-T
S6520	12	1/4"	AM25-T / AM30-T
S6520	12	3/8"	AM40-T / AM50-T
S6520	14	3/8"	AM40-T / AM50-T



FIXATION BRACKET

Part Number	Air amplifier
ABT-05T	AM-10T / AM-15T
ABT-05	AM-20T / AM-25T

On request, with fixation holes*.

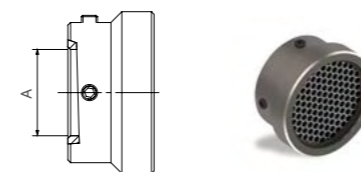
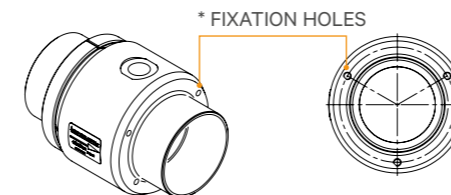

FILTERS FOR FIXATION TO CABINETS

Part Number	Air amplifier	A Ø
AC32	AM-10T / AM-15T	19
AC31	AM-20T / AM-25T	32
AC26	AM-30T	38
AC43	AM-40T	50
AC44	AM-50T	63

SPECIAL APPLICATIONS

AIR-SPEED 25 • SUCTION GUN

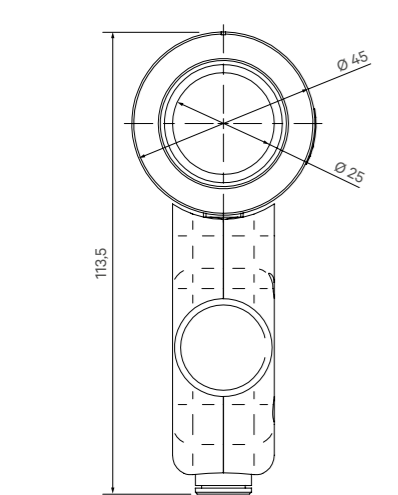
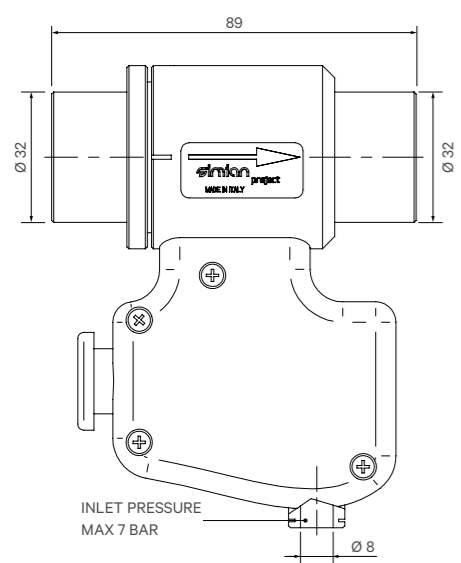
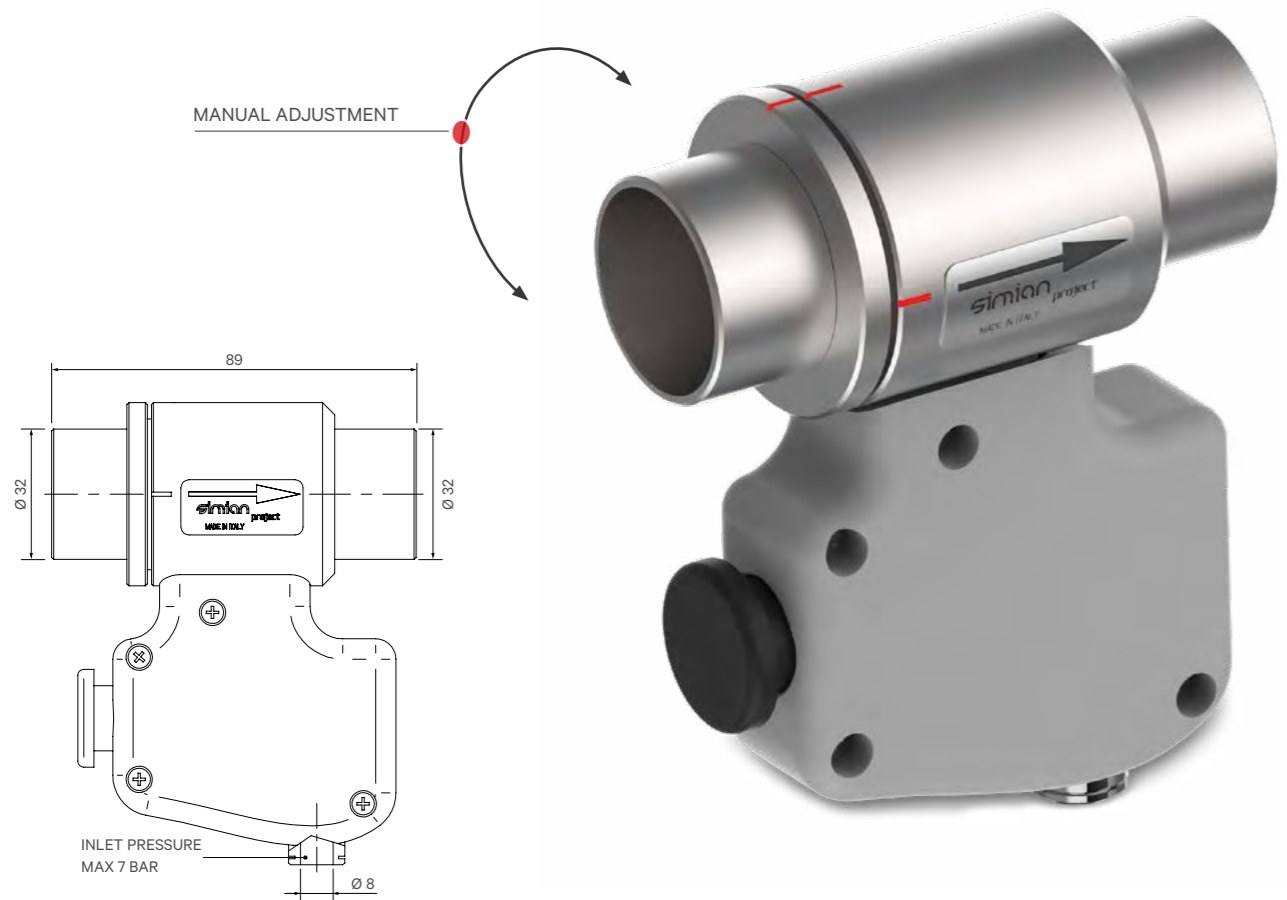

GENERAL FEATURES - AIR-SPEED 25

Materials	Aluminium
Supply connection	Ø 8 x 1
Inlet diameter	Ø 32
Outlet diameter	Ø 32
Air supply pressure	max 7 bar

On request, available in version for blowing.

SPECIAL APPLICATIONS

AIRCLEAN 30

FUNCTIONING PRINCIPLE

By opening the rear ball valve, the compressed air activates the **AM-30T** amplifier (recommended pressure: 3 - 5 bar), whose amplified and powerful flow gets out from the tapered outlet. The handle has length 1 m.

BENEFITS

- Manageability and robustness, as it is made of aluminium.
- Reduction of consumption, thanks to the air amplifier.
- High power of the air flow.



FIELDS OF USE

- Cleaning of large conveyor belts (waste sector, mining sector, etc.);
- Cleaning of hoppers in the construction industry, etc.;
- Cleaning of large components in the aeronautic, rail, and marine sectors;
- Cleaning of silos, metallic carpentry, etc.



DEVICES DESIGNED TO RESPOND TO VARIOUS REQUIREMENTS IN THE AUTOMATION FIELD, AS LISTED BELOW:

- **Nozzles series UGP** - In-line blowing
- **Nozzles series UGL** - Cleaning of rectangular photocells
- **Nozzles series UGD** - Cleaning of optical sensors and photocells
- **Nozzles series UGF** - Cleaning of optical fibers
- **Nozzles series UGF** - Cleaning of optical fibers

Possibility of customisation, both in terms of materials and dimensions



UGP 20A



UGP 20B

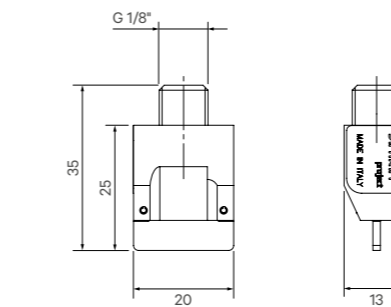

UGP 20A

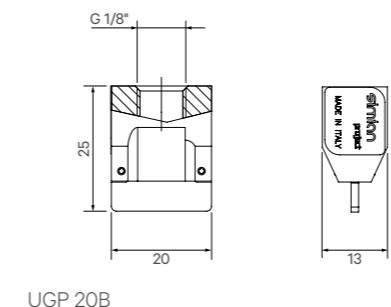

UGP 20B

GENERAL FEATURES - UGP 20A - UGP 20B

Material	Delrin and AISI304 stainless steel
Inlet port	G 1/8" M (UGP 20A) G 1/8" F (UGP 20B)
Flow width	20 mm
Supply pressure	1 ÷ 7 bar
Weight	18 g (UGP 20A) 12 g (UGP 20B)

PERFORMANCES AND CONSUMPTION TABLE

PRESSURE	AIR CONSUMPTION	THRUST*	NOISE LEVEL
bar	NI/min	Grams	dBA
1	95	50	62
2	154	130	67
3	220	200	71
4	286	290	75
5	345	370	78
6	404	460	80
7	460	550	83

*Thrust force (in grams) measured at a distance of 200 mm.

SERIES UGP 45A - UGP 45B

FLAT-FLOW NOZZLES

SERIES UGL

NOZZLE FOR RECTANGULAR PHOTOCELLS



UGP 45A



UGP 45B

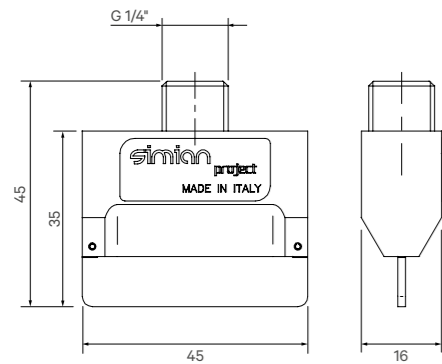
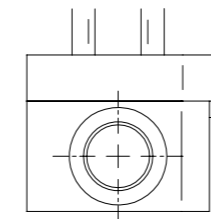

UGP 45A

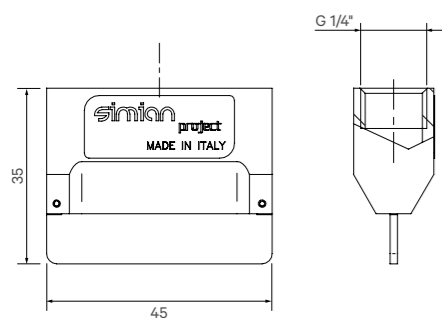

UGP 45B

GENERAL FEATURES - UGP 45A - UGP 45B

Material	Delrin and AISI304 s.s.
Inlet port	G 1/4" M (UGP 45A) G 1/4" F (UGP 45B)
Flow width	45 mm
Supply pressure	1 ÷ 7 bar
Weight	32 g (UGP 45A) 25 g (UGP 45B)

PERFORMANCES AND CONSUMPTION TABLE

PRESSURE bar	AIR CONSUMPTION Nl/min	THRUST* Grams	NOISE LEVEL dBA
1	130	80	65
2	231	180	70
3	340	290	73
4	436	410	77
5	540	550	80
6	650	700	82
7	780	850	83

*Thrust force (in grams) measured at a distance of 200 mm.

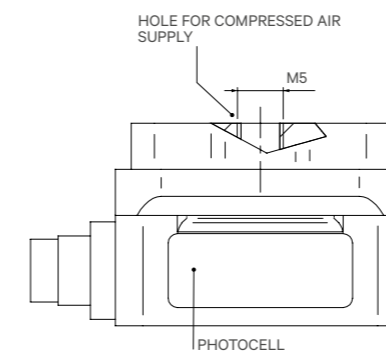

GENERAL FEATURES - UGL

Material	On request
Inlet port	Not included
Dimensions	On request

PERFORMANCES AND CONSUMPTION TABLE

PRESSURE bar	CONSUMPTION NL/MIN
0,2	13

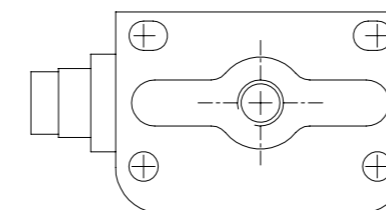

SERIES UGD 18-I

NOZZLE FOR CLEANING

SERIES UGD 08 / UGD 12 / UGD 18 / UGD 30

NOZZLE FOR CLEANING



DIMENSIONS - UGD 18-I

Material	Moulded Nylon		
Type	A	B	C
UGD-18I	M18x1	42	26

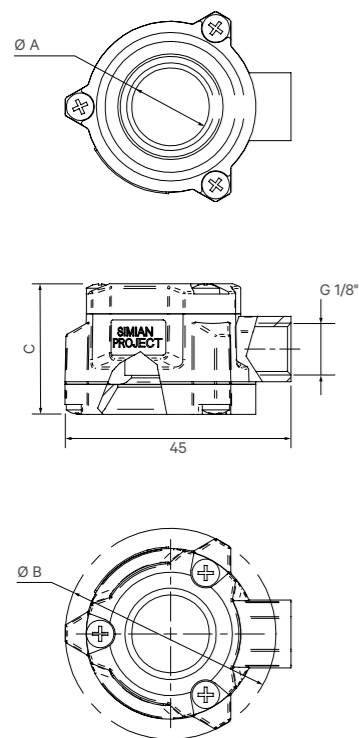

PERFORMANCES AND CONSUMPTION TABLE

	PRESSURE bar	CONSUMPTION l/min
	0,2	21
	0,3	28
	0,4	40
	0,5	48

DIMENSIONS - UGD 08 / UGD 12 / UGD 18 / UGD 30

Material	Aluminium		
Type	A	B	C
UGD-08	M8x1	27	9
UGD-12	M12x1	32	11,5
UGD-18	M18x1	38	11,5
UGD-30	M30x1,5	50	13,5

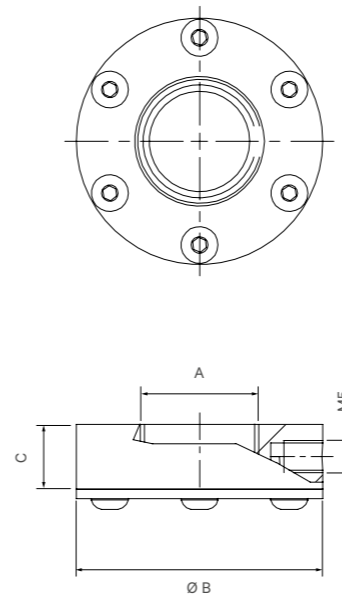

PERFORMANCES AND CONSUMPTION TABLE (ONLY VERSION UGD-18)

	PRESSURE bar	CONSUMPTION l/min
	0,2	21
	0,3	28
	0,4	40
	0,5	48

SERIES UGF 03 / UGF 04 / UGF 05 / UGF 06

NOZZLE FOR OPTICAL FIBER CLEANING

SERIES UGB 100 / UGB 300

AIR-KNIFE FOR LIGHT CURTAINS

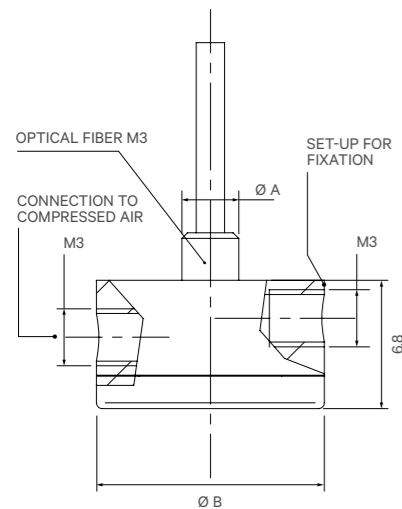
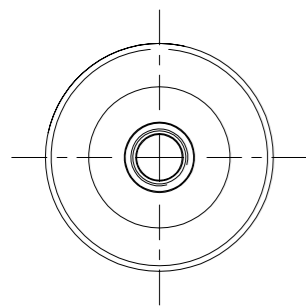
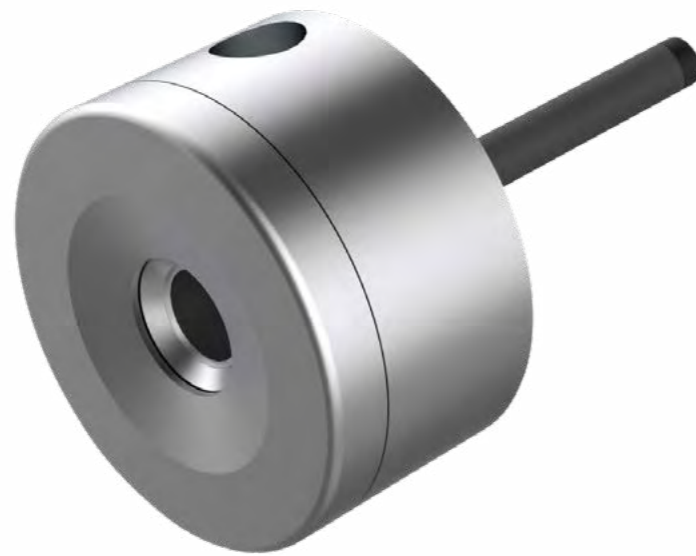

GENERAL FEATURES - UGF 03 / UGF 04 / UGF 05 / UGF 06

Material	Anodized aluminium	
Inlet fitting	Not included	
Dimensions	Ø A	Ø B
UGF 03	M3	12 mm
UGF 04	M4	15 mm
UGF 05	M5	15 mm
UGF 06	M6	16 mm

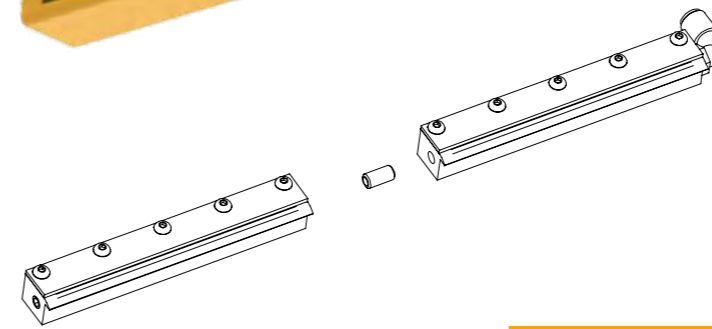
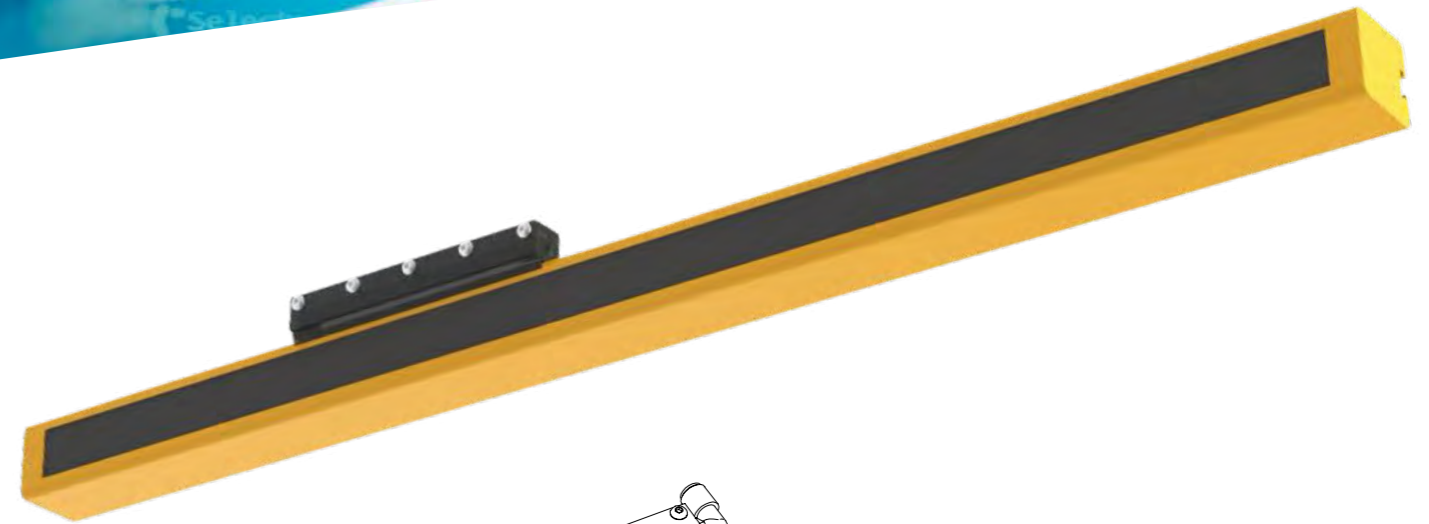

MULTIPLE SOLUTION

GENERAL FEATURES - UGB 100 / UGB 300

Material	Alluminio anodizzato / Delrin
Inlet fitting	Not included
Curtain width	100 mm / 300 mm

PERFORMANCES AND CONSUMPTION TABLE

Pressione Bar	Consumption L = 300 mm m ³ /h	Consumption x 100 mm NI/min	Consumption x 100 mm NI/min
0,3	4	82	27
0,5	6	114	38
0,7	8	138	46
1	10	175	58
1,5	14	238	79
2	18	305	102
2,5	21	358	119
3	24	408	136
4	30	508	169

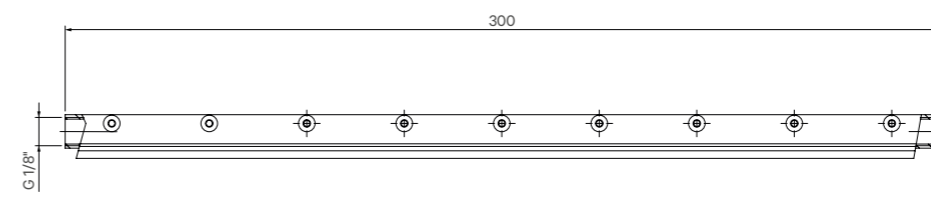
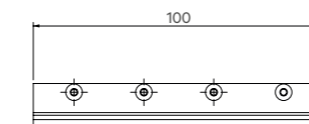
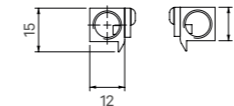



Series HSC

Effective, maintenance-free, and suitable for any flow-rate and application



The main strengths of the condensate separators **Series HSC** are effectiveness, reliability, and versatility.

The effectiveness in the removal of condensate is obtained through the particular design of the **DRYVOLUTION** system: thanks to a series of concentric flanges, assembled with a precise angle of incidence with respect to the direction of inlet flow, they generate a compressed air expansion (which takes place inside a chamber downstream of the flanges) that brings about a considerable decrease in the temperature and consequently the condensation of humidity. This is then directed to the bottom of the bowl.

The reliability derives from the fact that no electric power and no chemical

substance is used, and moreover there is no moving part (with the exception of the sole automatic drain): the performance is steady and maintenance is practically zero.

The versatility is guaranteed by the performances and the technical features: the range covers a wide spectrum of flow-rates and the materials used, together with the assembly, make it a very sturdy product. Therefore it perfectly suits many different applications at the end of the compressed air line and close to the point of use: on board of automatic machinery, before pneumatic tools, on board of trucks and agricultural machines, etc..

- Water separation through the decrease in the temperature of compressed air
- No moving part, except for the automatic drain
- Easy to install
- Made in technopolymer and brass OT58
- One size, with 3 possible flow-rate settings
- Maintenance-free
- Neither electricity nor chemical substances required
- Neither sparks nor interferences caused
- Instant operation



SERIES - HSC - T2 - HIGH SEPARATOR CONDENSE

THERMODYNAMIC DRYER

ACCESSORIES

THERMODYNAMIC DRYER



GENERAL FEATURES - HSC - T2

Type of functioning	Thermodynamic
Materials	Technopolymer
Ports	1/2" G (with bushings in brass)
Weight	500 g
Installation	Vertical
Operating temperature	-10°C + 50°C
Condensate drain	Automatic, by float
Medium	Compressed air
Operating pressure	Max. 12 Bar
Max. flow-rate (3 possible settings)	1266* NI/min at max. opening
Factory setting	Intermediate opening (1100 NI/min)

*values at P1= 6 Bar and Delta P= 0.5 Bar.

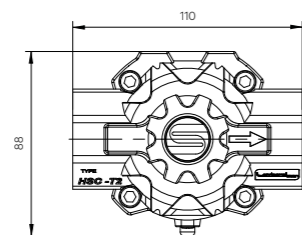
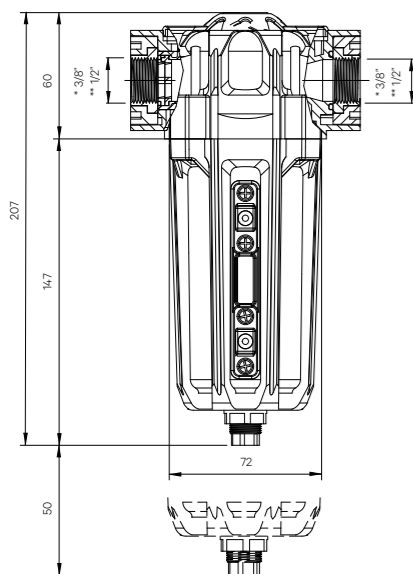

*HSC-02-38-SCC
**HSC-02-12-SCC

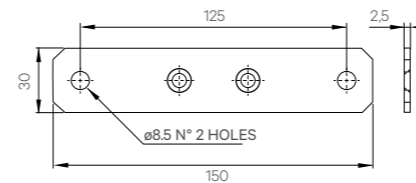
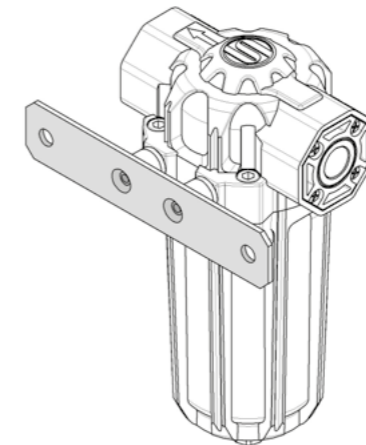

WALL BRACKET

PART-NUMBER	DIMENSIONS
HSC-13	150 x 30 x 2,50

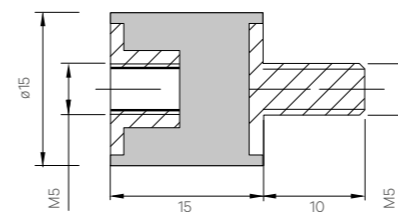

ANTI-VIBRATION SUPPORT

PART-NUMBER	DIMENSIONS
HSC-17	15 x 15 M5

SOME EXAMPLES OF APPLICATIONS



Cooling of blisters



Cooling of tools

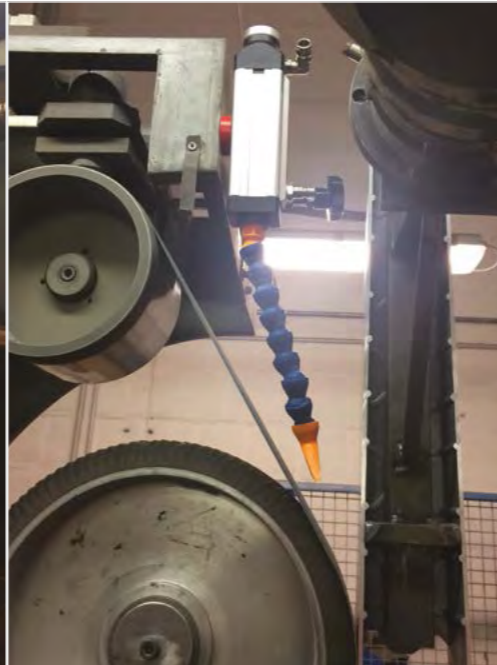

Cooling of belt sander

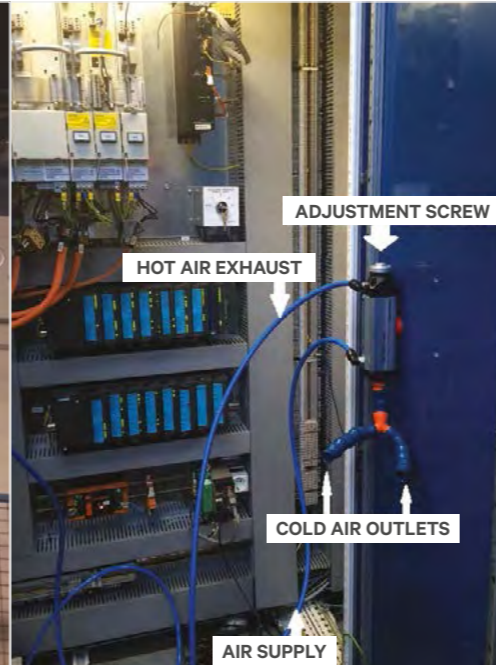

Cooling of control cabinets



Cooler for plastics' processing

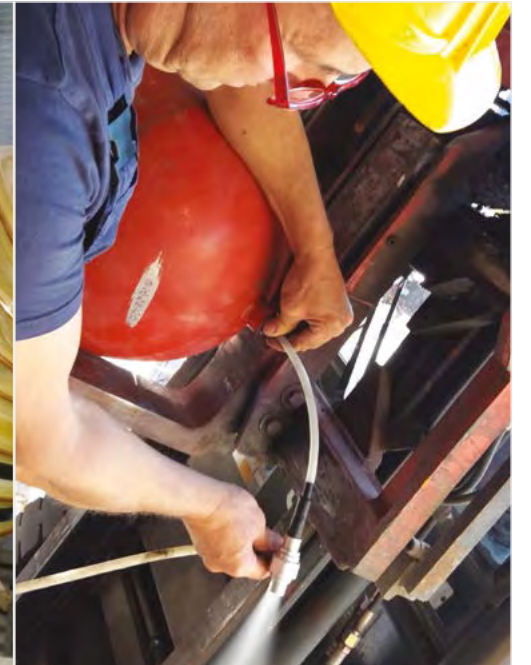

Amplifier for suction of liquids

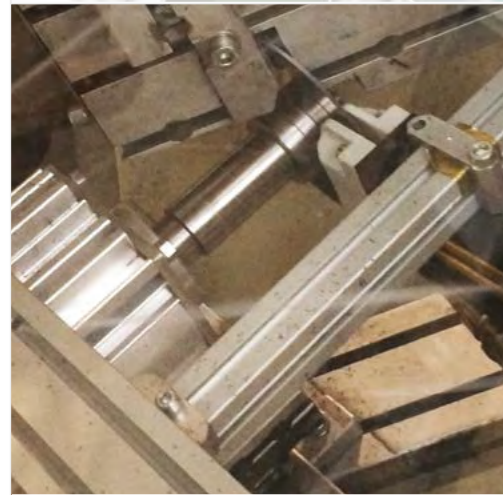

Cooling of blades

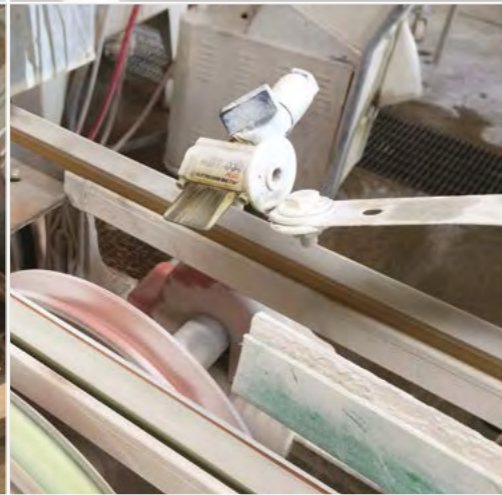

Air knife to clean tiles

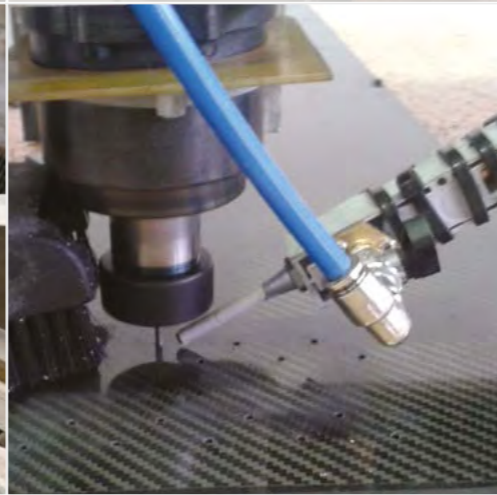

Cooler for carbon fiber's tooling



Cooling of sprues - Moulding sector



Cooler for making window fixtures



Cooler for machine-tool



Cooling of moulds in foundries

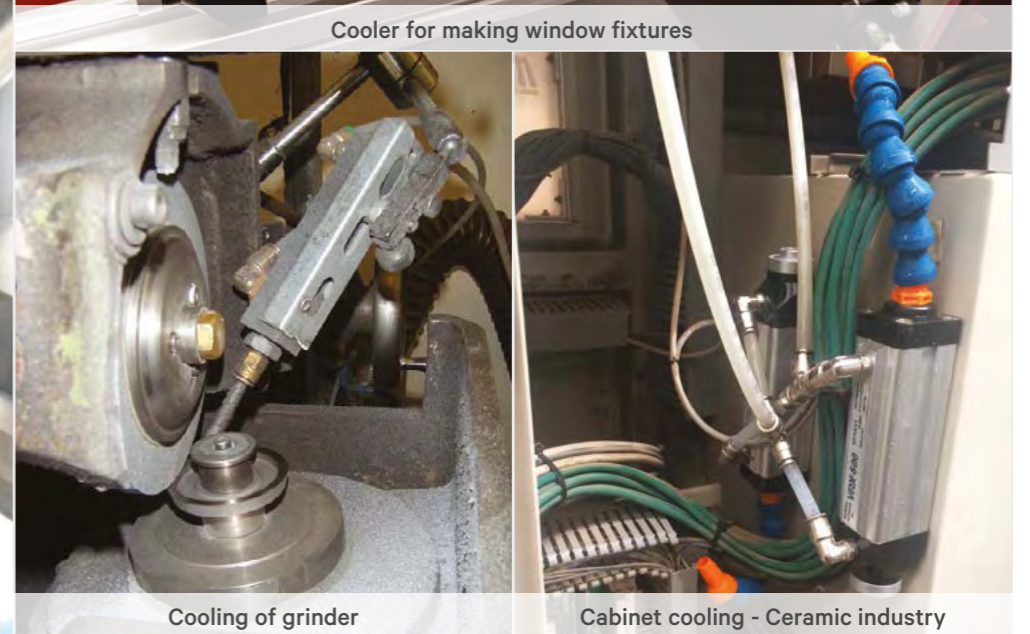

Cooling of grinder



Cabinet cooling - Ceramic industry

SOME EXAMPLES OF APPLICATIONS



Air knife to dry pharma containers



Cooling of glueing station



Cooling down of tool - Woodworking sector



Air knife for defective parts' discard



Cooler for hydraulic application



Amplifier to dry plastic wire



Air amplifiers for profiles' cleaning



Air knife to clean machine-tool window

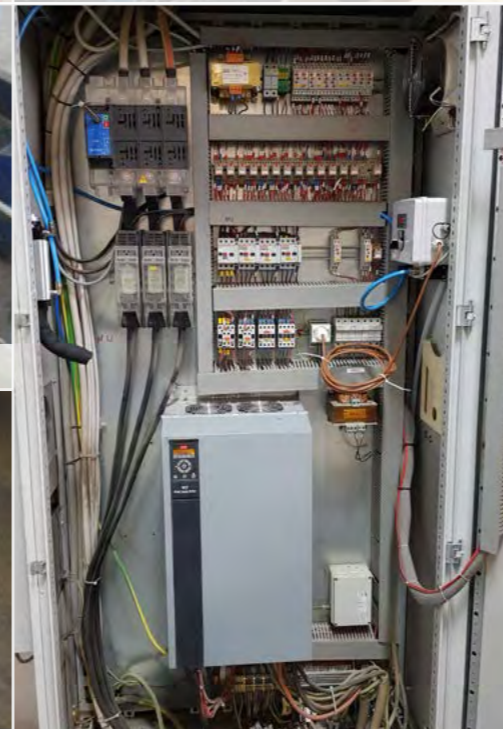

Cooling of cabinets (with control unit)



Cooling of blades



Cooling of control cabinets



Air-knife to stretch films



Cooling of cabinets



Cooling of junction boxes



Cooling of a tool - Plastics sector



Air knives to detach metal sheets



Pnevano

+32 3 355 32 20 | www.pnevano.com